

# BROADCAST NEWS

MULTIPLE ANTENNA  
SYSTEM  
WBAL-TV, WJZ-TV  
WMAR-TV  
BALTIMORE, MARYLAND



VOL. No. 106  
DECEMBER 1959



# 5000- WATT

# AM

# TRANSMITTER



Type BTA-5R/5R1

## INTRODUCES ADVANCED SILICON HIGH VOLTAGE RECTIFIERS

The compact BTA-5R/5R1 is available with a choice of tube rectifiers or new long-life silicon rectifiers. Only two tuning controls make this transmitter ideal for reliable remote control operation. Instantaneous Conelrad frequency switching is also available. Vertical chassis construction provides easy front and rear access to all components.

Silicon rectifiers, tested in a pre-production model of the BTA-5R1, were subjected to aging, estimated to be equivalent to 20 years, while the remaining portions of the transmitter also met severe tests. All of them proved the ability of these transmitters to perform over long periods under adverse conditions. The reliable silicon type of rectifier is ideal in remote control applications. The transmitter will operate within ambient temperatures from  $-4$  to  $+113$  degrees F. and to 7500 feet above sea level.

A unique exciter features plug-in crystal oscillators (this is the exciter proved in the BTA-500R/1R). Three switchable crystal positions are provided for: (1) an operating crystal, (2) a spare on the main channel, and (3) provisions for optional instantaneous Conelrad switching. High-fidelity performance is assured with the new 3X3000 F1 modulator tubes that *do not draw grid current* to modulate the two long-life 5762 PA tubes. Overall AF response is  $\pm 1.5$  db from 30 to 10,000 cycles.

For further information about these and other transmitters, call the nearest RCA Broadcast representative. Or write to RCA, Dept. UB-22, Building 15-1, Camden, N. J. In Canada: RCA VICTOR Company Limited, Montreal.

### OUTSTANDING FEATURES

- Built-in provision for remote control
- Unique exciter with plug-in oscillator
- Instantaneous Conelrad frequency switching (optional)
- Silicon rectifiers (optional)
- Only two tuning controls
- High fidelity performance



Tmk(s)®

## RADIO CORPORATION of AMERICA

BROADCAST AND TELEVISION EQUIPMENT

CAMDEN, NEW JERSEY

Vol. No. 106

December, 1959

# BROADCAST NEWS

*published by*

**RADIO CORPORATION OF AMERICA**  
BROADCAST & TELEVISION EQUIPMENT DIVISION  
CAMDEN, NEW JERSEY

*issued quarterly*

**PRICE** *in U.S.A. - - - - \$4.00 for 4 issues*  
*outside U.S.A. - - - \$5.00 for 4 issues*

## CONTENTS

	Page
JAPANESE NETWORK ADDS COLOR TV TAPE RECORDER . . . . .	6
RCA DEMONSTRATES TV TAPE INTERCHANGEABILITY . . . . .	8
KWTV EXPLOITS BENEFITS OF RCA TV TAPE . . . . .	10
TV STATIONS REPORT ON RCA TAPE PERFORMANCE . . . . .	12
MOBILE TAPE UNIT AIDS MILITARY TRAINING . . . . .	14
MERRILL TRAINER HEADS NEW DEPARTMENT . . . . .	15
SERVICE COMPANY EXPANDS TAPE TRAINING PROGRAM . . . . .	16
HOW WWL-TV PLANNED A FORWARD-LOOKING INSTALLATION . . . . .	18
WGAN-TV ERECTS THE WORLD'S TALLEST TOWER . . . . .	28
WBAL, WJZ, AND WMAR BUILD 3-ANTENNA CANDELABRA . . . . .	30
NEW "B" SERIES TRAVELING WAVE ANTENNA . . . . .	36
DUAL-PURPOSE 12-INCH TURNTABLE . . . . .	42
EQUIPMENT FOR MEASURING ENVELOPE DELAY . . . . .	44
NEW SPECIAL EFFECTS SYSTEM . . . . .	48
HOW TO GET TOP PERFORMANCE FROM TVM-1A MICROWAVE . . . . .	55
WTOP MODERNIZES AM TRANSMITTER PLANT . . . . .	64
NEW, COMPACT MASTER MONITOR . . . . .	69



A black and white photograph of a man in a suit, seen from the side, looking down and adjusting a control knob on a large, complex electronic device. The device has numerous knobs, buttons, and dials, with labels such as 'DELAY CHAN 1', 'DELAY CHAN 2', 'DELAY CHAN 3', 'DELAY CHAN 4', 'FM OUT', 'RECORD', 'PLAY', 'STOP', and 'EJECT'. The background is a light-colored wall with a subtle pattern.

**Only with RCA**  
**can you get the**

Why you get the best  
when you  
"TAPE IT RCA"

21 OUTSTANDING RCA FEATURES . . .

1. Centralized control panel including metering of audio, video, control track and master erase heads
2. Better than 36 db video signal-to-noise at wide bandwidth video
3. Quadrature delay lines, record and playback
4. Built-in picture monitor and oscilloscope with push-button selection of signals
5. Continuously variable winding speed
6. Foot-switch on reel brakes for easy tape threading
7. Air lubricated tape guides

*Don't settle for less than the best. See your RCA Representative, or write to RCA, Dept. YE-22, Building 15-1, Camden, N. J. In Canada: RCA VICTOR Company Limited, Montreal.*



Tmk(s) ®



# Electronic Quadrature Best Picture in Seconds!

—PLAY ANY TAPES AS THOUGH MADE ON  
AN ADVANCED RCA TV TAPE RECORDER!

*Electronic quadrature adjustment*, as offered by the RCA TV Tape Recorder, assures the best picture alignment *in seconds*, even in playing back tapes made on recorders without the advantages of RCA precision circuitry.

Two sets of four precisely adjusted electrical delay lines are provided, one set of which is used during the record operation, the other during playback. Once set, the *record* delay lines need not be changed until a new headwheel panel is installed in the machine.

The *playback* delay lines may be used at any time

a tape exhibits quadrature errors in playback. The appropriate tap switches are adjusted until horizontal displacement is corrected. All correction is accomplished quickly, during operation of the machine. And adjustment for record error can be made within a very few seconds after playback starts.

A tape recording can be made on an RCA machine with much more accuracy than with a machine that is adjusted mechanically. That's why we say, "For the picture of pictures, tape it RCA and play it back on an RCA TV Tape Recorder."

8. Space-saving rack mounted design
9. Four channel video equalizer
10. FM deviation meter
11. Coarse and fine adjustment of control track phase with full 4-track range
12. Simultaneous playback of program audio and control track during record
13. Playback tape speed control for synchronization of two or more machines
14. Tape footage indicator
15. Complete cue channel facilities
16. Calibrated control for measuring remaining video head life
17. Automatic control of shoe positioning for protection against skewing in pictures
18. Balanced shoe adjustment for protection against scallops in picture
19. Provisions for accurate tape splicing
20. Master erase head
21. Precision reel hubs for long bearing life

**RADIO CORPORATION of AMERICA**

BROADCAST AND TELEVISION EQUIPMENT • CAMDEN, N. J.



# COMPACT NEW 11 KW VHF TELEVISION TRANSMITTER

**Combines with an RCA High-Gain Antenna to Provide  
Effective Radiated Power Up to 180,000 Watts—  
Channels 7 to 13. An Unusually Low-Cost Package.  
(Or can be used as a driver to obtain higher power)**



The TT-11AH answers the need for a modern television transmitter for the high band. It is designed for remote control, ease of operation, and improved performance. It assures low operating and maintenance costs and minimizes space requirements.

Space savings are effected through the use of common power supplies, walk-in cabinetry, and improved equipment layout. As a result, a reduction in floor area up to 40%, compared

with previous 10 KW transmitter installations, can be realized.

By providing a wide aisle inside the enclosure, between the front-line racks and the power equipment to the rear, all components are readily accessible. Modulator and exciter chassis can be tilted out, from the front of the transmitter, for ease of servicing.

Check the outstanding features of this transmitter (at right) which make it easy and inexpensive to operate.

*Get the complete story from your RCA Broadcast representative or write for descriptive literature to RCA, Dept. AD-22, Building 15-1, Camden, N.J. In Canada: RCA VICTOR Company Limited, Montreal.*

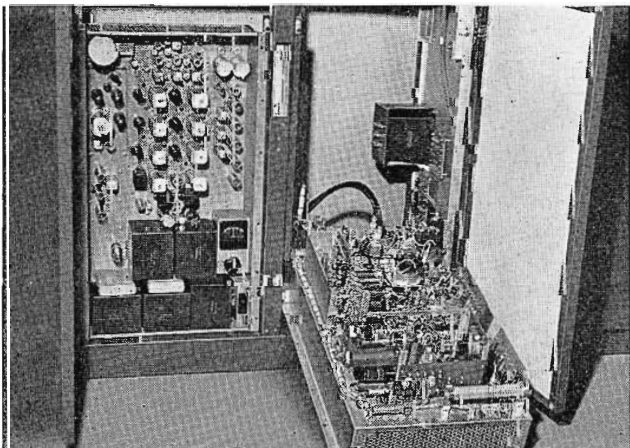

Modulator unit is shown tilted forward for ease of servicing; exciter unit is in normal position.



ANOTHER WAY  
RCA SERVES  
BROADCASTERS  
THROUGH  
ELECTRONICS

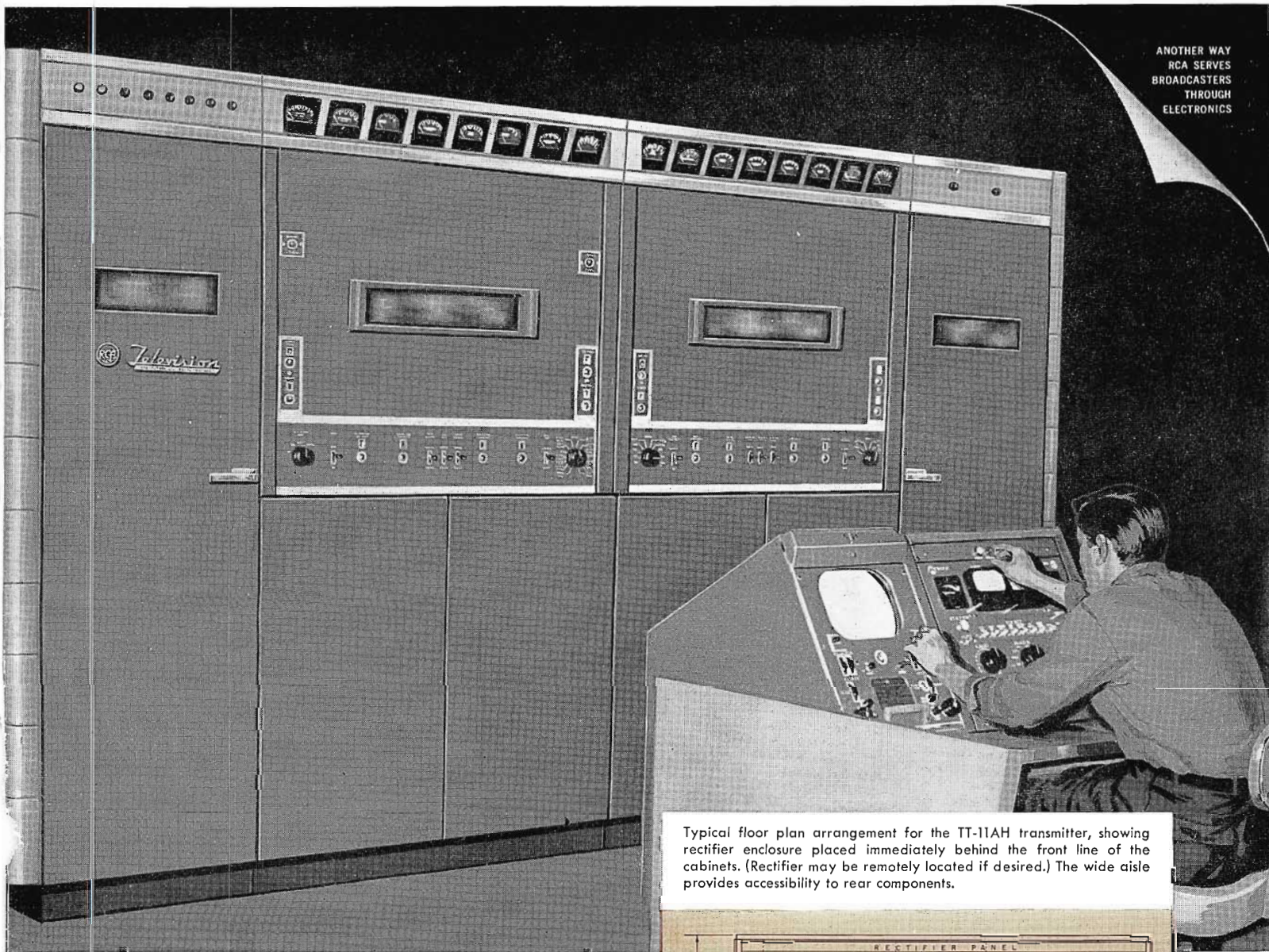

Typical floor plan arrangement for the TT-11AH transmitter, showing rectifier enclosure placed immediately behind the front line of the cabinets. (Rectifier may be remotely located if desired.) The wide aisle provides accessibility to rear components.

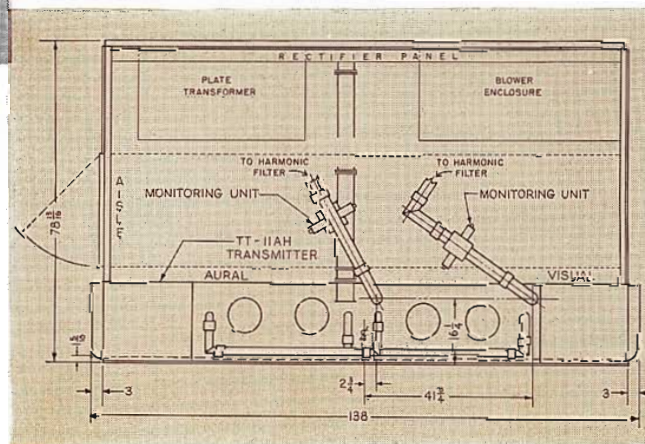

## THESE OUTSTANDING FEATURES

- 1 WALK-IN DESIGN ACCESSIBILITY**—Improved walk-in design, introduced with the TT-2BL and TT-6AL Transmitters, is an invaluable feature of the TT-11AH. A wide aisle is provided inside the enclosure between the front-line racks and power supply components to the rear. All components are readily accessible from this aisle.
- 2 TUNING SIMPLICITY**—All tuning adjustments can be made from the front of the transmitter with power applied. Power amplifier cavity has been greatly simplified, and no change in frequency-determining components is required to tune to any high-band VHF channel.
- 3 WIDE AMBIENT TEMPERATURE RANGE**—Operation over a wide ambient temperature range is provided by thermostatically controlled cooling of all mercury vapor rectifier tubes.
- 4 QUIET OPERATION**—All tubes and components, other than the mercury-vapor rectifier tubes, are cooled by one main blower in a sound-insulated enclosure.
- 5 OVERLOAD PROTECTION**—Overload protection is furnished for all circuits. Indicating lights in the control unit instantly show which circuit was at fault.
- 6 DESIGNED FOR REMOTE CONTROL**—Provisions have been made for remote metering and control of all necessary functions from a remote point. These facilities may also be used

to control the transmitter from a central point in the transmitter building.

- 7 FEWER TUBES AND COMPONENTS TO STOCK**—Fewer spare tubes and components need be stocked since the same tube types are used in both aural and visual rf chains.
- 8 ILLUMINATED METERS**—A row of large illuminated meters, mounted on a sloping-front panel for ease of reading, shows all important currents and voltages.
- 9 IMPROVED COLOR PERFORMANCE**—Built-in linearity correction, accurate intercarrier frequency control, and dc on power amplifier filaments are features included for outstanding color performance.



**RADIO CORPORATION of AMERICA**

BROADCAST AND TELEVISION EQUIPMENT • CAMDEN, N. J.





FIG. 1. Operations Center of the RCA TV Tape Recorder is unloaded at Tokyo Airport. The tape equipment will complement existing color facilities of the Nippon TV Network Corporation.



FIG. 2. Japanese singer and TV starlet, Kezz Takakuwa sees equipment off at Idlewild International Airport.

## JAPANESE NETWORK ADDS COLOR TV TAPE RECORDER

Nippon TV Network Corporation (NTV) Adds TV Tape  
To Existing Color Installation



FIG. 3. Deep interest by the Japanese in color television is reflected in the size and attention of this through viewing color programs at an outdoor demonstration.



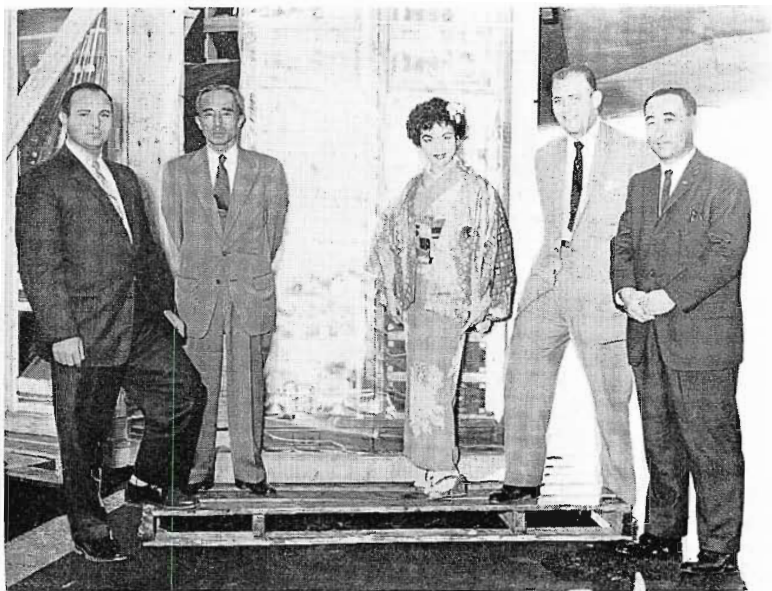

FIG. 4. Giving Color TV Tape a send off at Idlewild are (left to right) John Sierchio, RCA International; Isuyoshi Fukada, President, Okura Trading Corporation; Miss Takakuwa; George Brewster, RCA International; and Frank Takebe, Okura Trading Corporation.

Japan's first color tv tape recorder has been installed by the Nippon TV Network Corporation (NTV). Shipped via air freight, the new equipment will be used to increase substantially the amount of color programming already being broadcast by the network.

One of its initial services will be to rebroadcast color tape recordings of the Perry Como show under an agreement with the National Broadcasting Company. With the new RCA Color Tape Recorders in use at both NBC and NTV, it will not be necessary to send a headwheel along with each tape (as would previously have been done) because complete interchangeability

of heads in the RCA TV Tape Recorder has been demonstrated.

The Japanese have shown strong interest in color television since NTV began colorcasts last year. An average of two hours each evening is broadcast in the Greater Tokyo area. As a public service, NTV has placed 50 color receivers at strategic spots along Tokyo's main shopping street, the Ginza, and in other places including the Tokyo railroad station. During color broadcasts, these draw overflow crowds.

A majority of the programs to be taped with the RCA recorder will be dramatic presentations, but sports also will figure in the overall schedule.

The tentative schedule calls for coverage of baseball games, ice skating events, skiing and soccer matches.

According to NTV officials, the RCA tv tape recorder will help the broadcasting company trim color production costs. Using the same production crews and equipment — and in some instances the same talent — several shows can be taped, in sequence in a single recording session.

The recorder, which is capable of production of black-and-white tapes as well as color, also will be used to tape monochrome material for use on the NTV network, extending to stations beyond the area of color receiver concentration.



FIG. 5. Five RCA Color TV cameras are now in use by NTV which recently placed the first commercial color station on the air in Japan.



# INTERCHANGEABILITY OF RCA TV TAPE

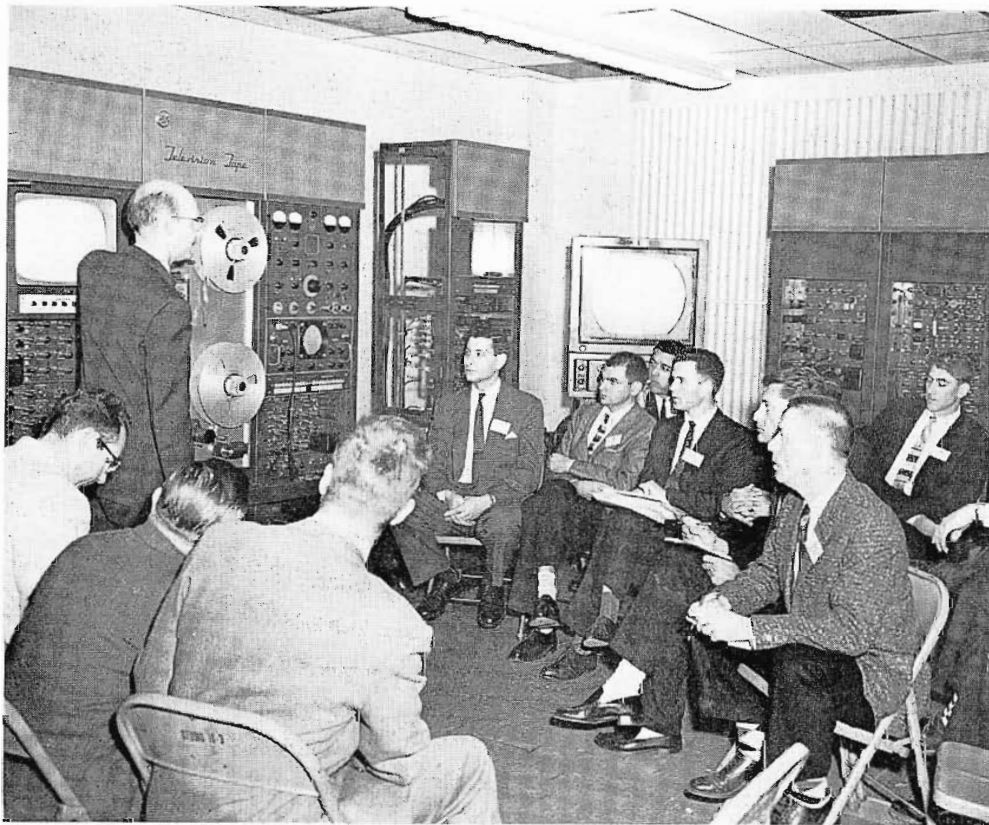

**TV Station Personnel See How Problem of Interchangeability Is Solved By Newest RCA Development.** — A seminar on tv tape was held recently in the RCA plant, Camden, N. J. Many engineers and managers of TV stations were in attendance. For several days there were presentations on the theory and operation of tv tape systems. Features of the RCA Advanced TV Tape Recorder were demonstrated: Centralized control; Continuous adjustment of speed; Independent controls for cue and program audio; FM deviation meter; Electronic quadrature adjustment. The climax of the seminar was a demonstration of how simple it is to get high quality playback of tapes made on other machines.

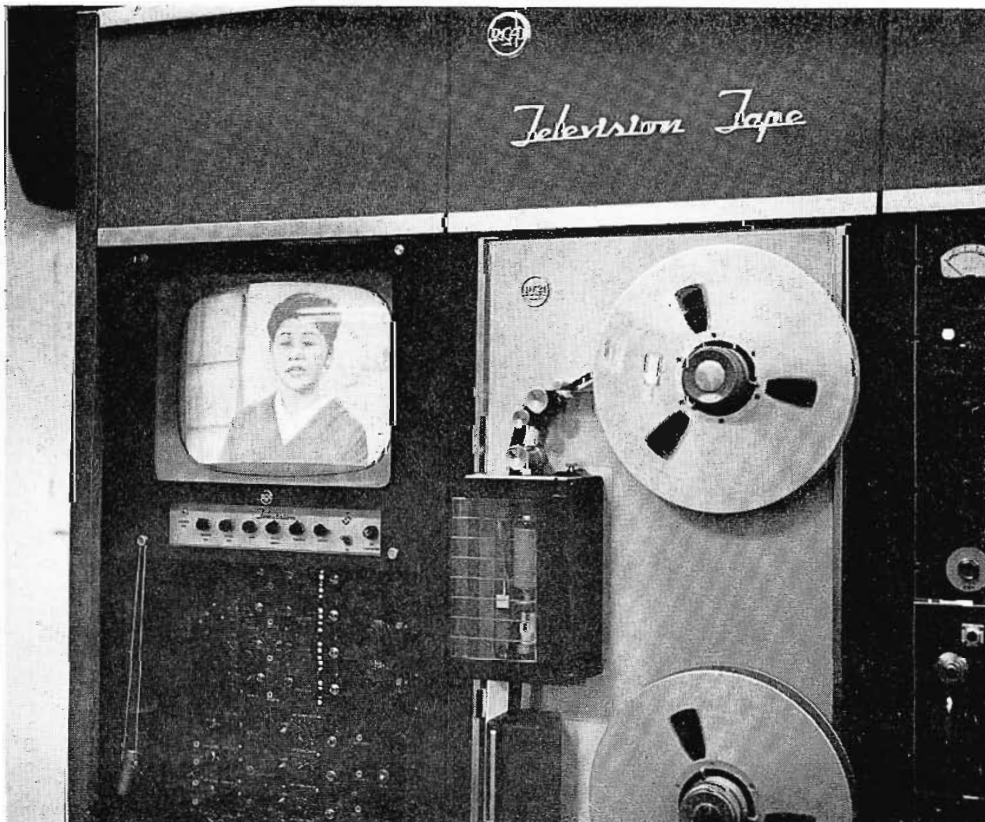

**Color Tape Recording Made In Japan Is Played Back In Camden, N. J., to Demonstrate Compatibility.** — Using a reel of tv tape recorded by NTV (Nippon TV Network Corporation) the RCA Advanced Tape Recorder was put to the test. After a few adjustments—made while the machine was running—a beautiful color picture was played back. The picture was eminently satisfactory for on-air use. Repeated playback brought equally satisfactory results. The original headwheel was not shipped with the tape,—which was played back using the regular headwheel on the machine. This demonstration proved that a color (or monochrome) tape made on one RCA machine can be played back on any other—with quality reproduction.



# DEMONSTRATED TO TELEVISION INDUSTRY

**Mr. C. H. Colledge Shows Precision Headwheel Assembly That Makes Possible Interchangeability of TV Tapes.** — General Manager of the RCA Broadcast and Television Equipment Division, Mr. Colledge, stated at the seminar that the RCA Advanced Recorder is designed to achieve interchangeability of tapes. The RCA recording heads are all manufactured to such extremely close mechanical tolerances that, together with electronic quadrature control, they afford the kind of electrical precision never before attained. This results in a far better picture, as well as TV Tape interchangeability. Furthermore, it is not necessary to adjust the headwheel mechanically. Merely a knob adjustment of the electronic quadrature controls puts a tape "on the track" for errorless playback.

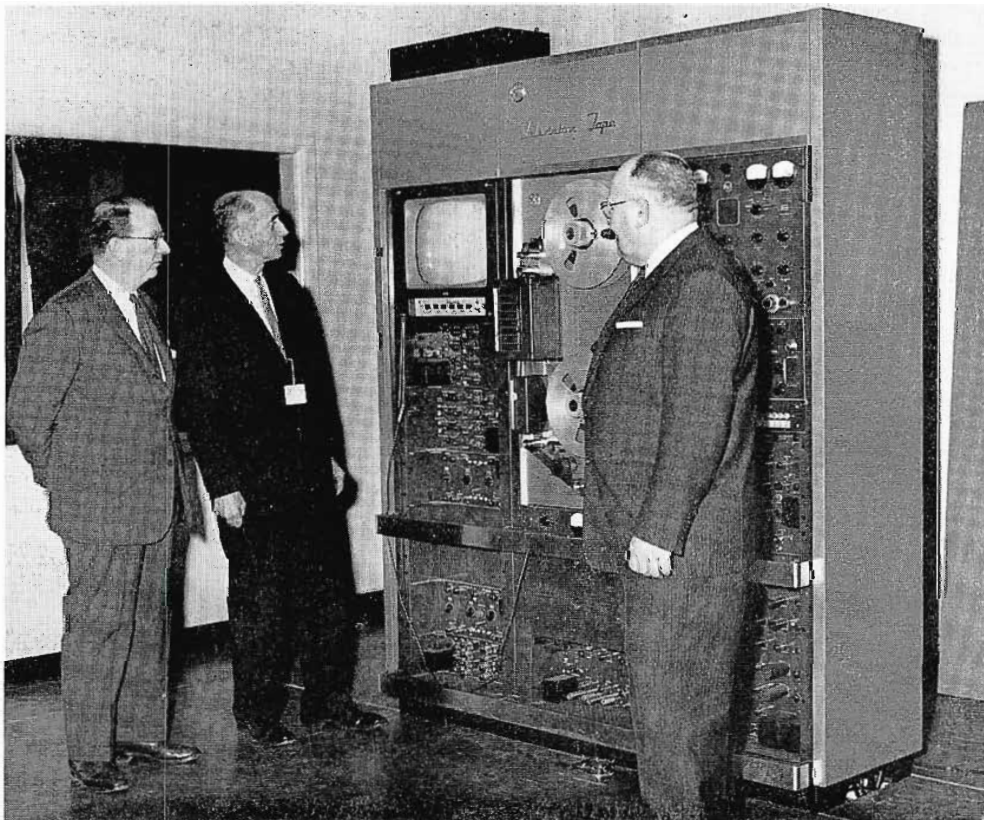
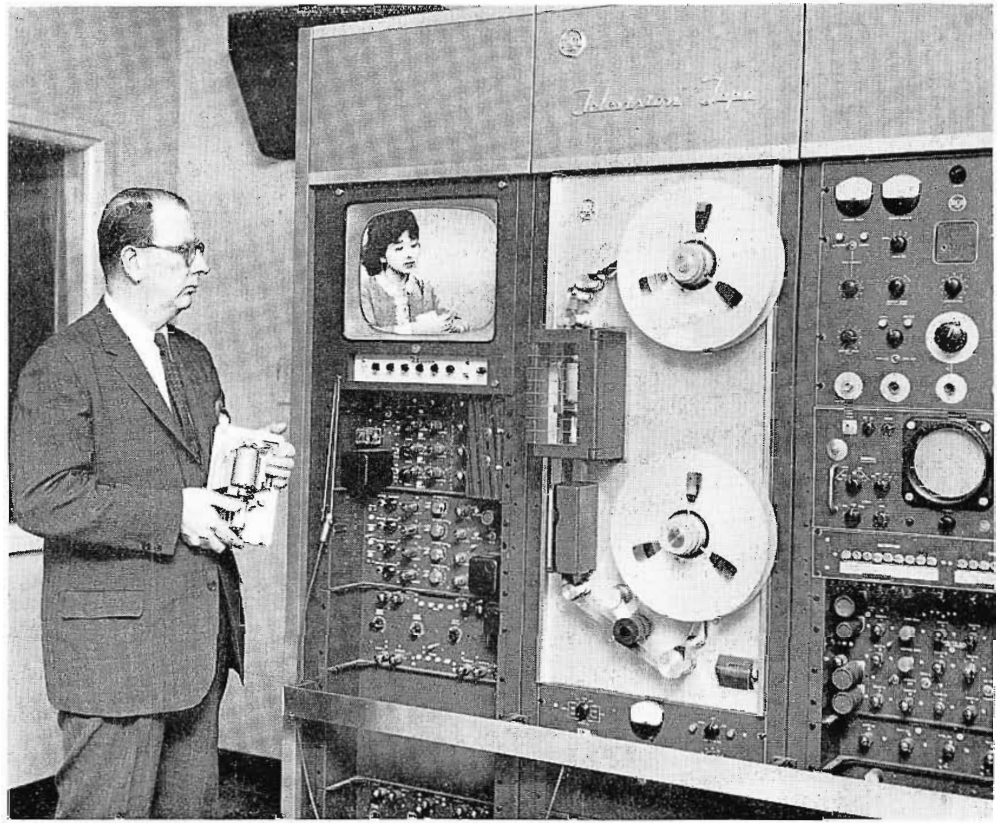

**Users of Color TV Tape Need Not Store Headwheel Assembly to Get Satisfactory Reproduction.** — The heart of the TV Tape Recorder is the headwheel assembly. In its recently-expanded magnetic-head manufacturing plant, RCA has developed methods for procuring more accurate mechanical alignment and highly uniform electrical characteristics. This precision in headwheel manufacture paves the way for broader use of TV Tape in both monochrome and color. It is now possible to achieve interchangeability between color tapes made on machines of different manufacture. As a result, color tape can be handled with the same ease as monochrome.



**KWTV**

OKLAHOMA CITY

From the desk of  
**EDGAR T. BELL**  
General Manager

*We waited for RCA!*

*KWTV being fully RCA equipped, we felt confident the recognized leader in the field of broadcast equipment would offer superior features in its Television Tape Recorder, and our clients would benefit if we waited for RCA.*

*Here is a brief description of the many advanced features of the new RCA Television Tape Recorder and what you can expect when you use KWTV's taping facilities.*

*We're glad we waited for the leader ... RCA!*

*Edgar T. Bell*

## KWTV EXPLOITS THE

"WE'RE GLAD WE WAITED FOR RCA", declares Edgar T. Bell, General Manager, KWTV, Oklahoma City, in a letter mailed to about 5000 advertisers and advertising agency personnel.

The letter accompanied a special brochure, prepared by the station, in which the advanced features of KWTV's new RCA TV Tape Recorder were explained and illustrated. Those features which provide extra client benefits were highlighted; such as easy tape handling, electronic quadrature adjustment, cue facilities and audio dubbing.

KWTV points with pride at the quality of pictures produced by their TV Tape Recorder. Advertisers and agencies have been

FIG. 1. Covering letter (left) and portion of a special brochure (below) sent by KWTV to a list of 5000 advertisers and advertising agency personnel to introduce new TV Tape equipment.





# BENEFITS OF RCA TV TAPE RECORDER

delighted with the quality turned out. Station engineers report that they find all components very well placed for finger-tip control and accessibility. The rack-mounted design of the RCA Recorder has permitted installation within existing facilities and has provided engineers with almost as much operating space as was available before it was installed.

The letter and a portion of the brochure are reproduced here as an example of how KWTW is promoting its new TV Tape facilities. This aggressive promotion plus the excellent performance of the advanced TV Tape equipment is succeeding in making KWTW clients increasingly tape-conscious.

FIG. 2. "The wonder of it all!" says KWTW General Manager Edgar T. Bell, as he listens to the audio playback of a tape as it is being recorded. This continuous audio quality check is one of the advanced features of the RCA Television Tape Recorder.

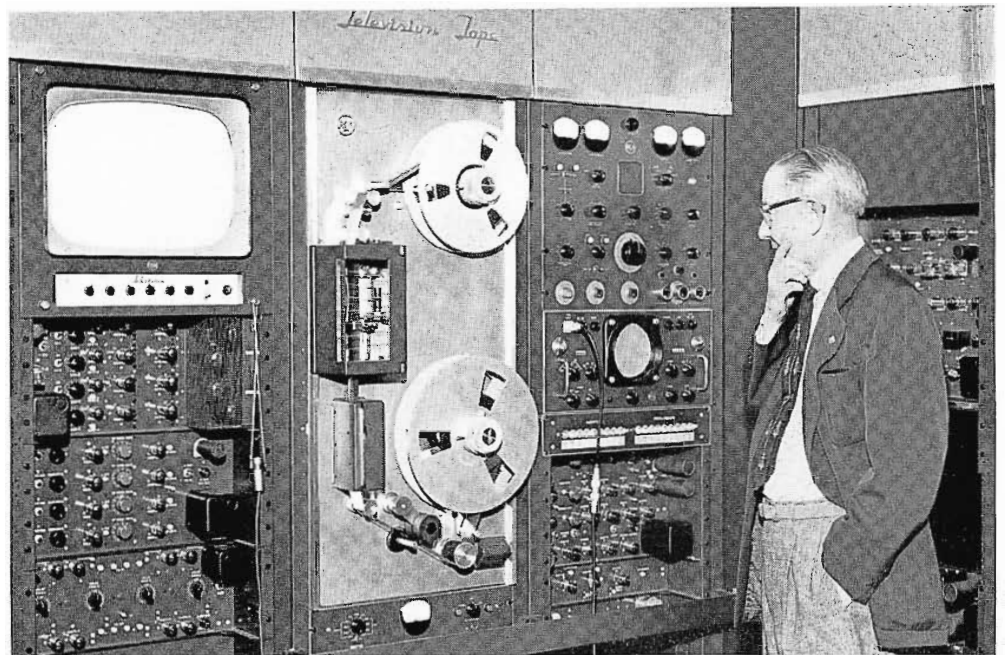

In television tape recording, the quality of the picture is all important . . . and KWTW taping facilities offer advertisers all the clarity, sharpness, and realism of "live" production.

Listed here are a few of the advantages of television tape recording and the advanced features of KWTW's RCA Television Tape Recorder—

- ▶ Immediate playback of video, as well as audio recording.
- ▶ RCA TV Tape Recorder provides for erasing and re-recording of audio portion of tape without disturbing video.
- ▶ Master erase equipment allows selective erasing of tape, enabling the operator to erase and re-record portions of the tape without erasing the entire reel.
- ▶ RCA's exclusive electronic quadrature precision adjustment assures alignment of video heads for an accurate picture in seconds. For example, tapes recorded on mechanically adjusted machines where quadrature is out of tolerance can be quickly brought back into alignment.
- ▶ Playback of audio, as it is being recorded, provides continuous monitoring of quality and content . . . an exclusive RCA feature.
- ▶ Variable forward and reverse controls provide rapid cueing of taped material . . . an important time-saver.
- ▶ Cue information channel—Space has been provided for recording of audio information on the 2-inch wide tape for cueing, special instructions for editing and splicing, time checks, etc., to be monitored later during playback. At KWTW this recorded information is available through speakers to operating personnel such as director and projectionist.
- ▶ Footage indicator numerically displays the number of feet of tape used, greatly aiding rapid cueing, editing and timing.
- ▶ Extra capacity tape reels allow continuous recording of 96 minutes on one 14-inch reel.
- ▶ Air lubricated tape guides—Tape sides on a cushion of air, reducing tape wear and providing accurate tape positioning.

... a  
**masterpiece  
of program  
convenience  
and superior  
performance**

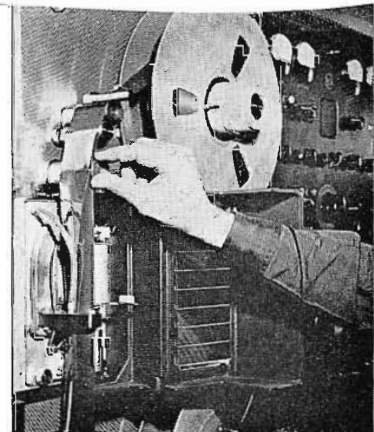

The 2-inch tape on the RCA Television Tape Recorder is threaded over air lubricated guides which provide a cushion of air which reduces tape wear.



Electronic quadrature adjustment, an exclusive RCA feature, assures the best picture accuracy in seconds, even in playing back tapes made on other recorders. Here, Maintenance Engineer Charlie Sheaffer checks voltage output before a taping session.



# STATIONS REPORT ON

## WTVR "We capture the news on RCA TV Tape" states Wilbur M. Havens, President and General Manager.

Use of the new TV Tape Recorder enables WTVR's remote news trucks, equipped with microwave facilities, to capture the news as it happens, relay it to the studio where it is recorded, edited, and immediately placed on the air.

The equipment was received on November 16, 1959 and placed into operation the same day. Its installation is part of a remodeling program to the WTVR building and control room facilities.

FIG. 1. Wilbur M. Havens, left, President and General Manager of WTVR, hands first taped program made on newly installed RCA TV Tape Recorder to James W. Kyle, Chief Engineer.

## KPHO-TV "We like TV Tape's operational convenience and accessible rack mounted design" reports George McClanathan, Director of Engineering.

Among the many advanced features of the RCA TV Tape Recorder KPHO-TV engineers are particularly impressed with the excellent accessibility of control and easy maintenance.

This operational convenience allows personnel to produce and maintain consistently high quality pictures so important to the station's clients. KPHO-TV is the first station in the Southwest to install RCA TV Tape recording facilities.

FIG. 2. KPHO's Director of Engineering, George McClanathan points to the recording head of KPHO-TV's new RCA Television Tape Recorder as KPHO-TV's Engineering Supervisor, Glenn Thompson looks on.



# TV TAPE PERFORMANCE

## WBAP-TV "TV tape strengthens our color programming" declares Rupert Bogan, Engineering Director.

One of the early pioneers of color television, WBAP-TV has completed their color facilities with RCA color TV Tape.

The equipment was installed in only two hours and was put into use immediately by the station where new packages and products are being color-tested daily.

The in-line arrangement of the basic recorder plus the color accessory rack has been installed in one of the station's video control rooms.

FIG. 3. First color tape recorder in Texas was installed in October, 1959 at WBAP-TV. The new equipment will play an important part in the stations continuing local color efforts.



## KBTV "TV tape will enable our present staff to handle increased business" says John C. Mullins, President.

Installation of two RCA TV Tape Recorders in new studio and control facilities adds increased flexibility to production scheduling at KBTV. Practically all morning programs up to 11 A.M. are being pre-recorded. Also the bulk of Saturday and Sunday programming is on tape.

This production convenience is enabling the station to handle an appreciable increase in new business with the present staff and has paved the way for extensive production of local commercials on tape.

FIG. 4. Two TV Tape recorders at KBTV are examined by (left to right) James Butts, Chief Engineer; Joe Herold, Station Manager, and John C. Mullins, President.

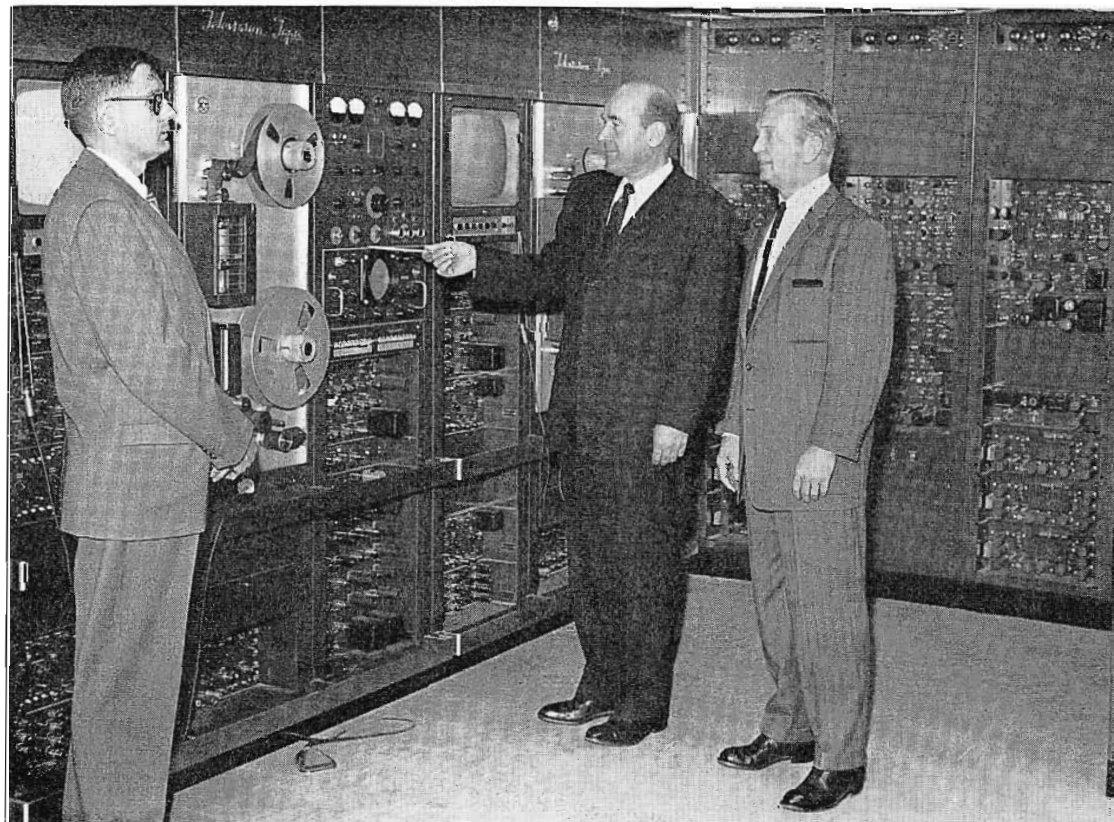
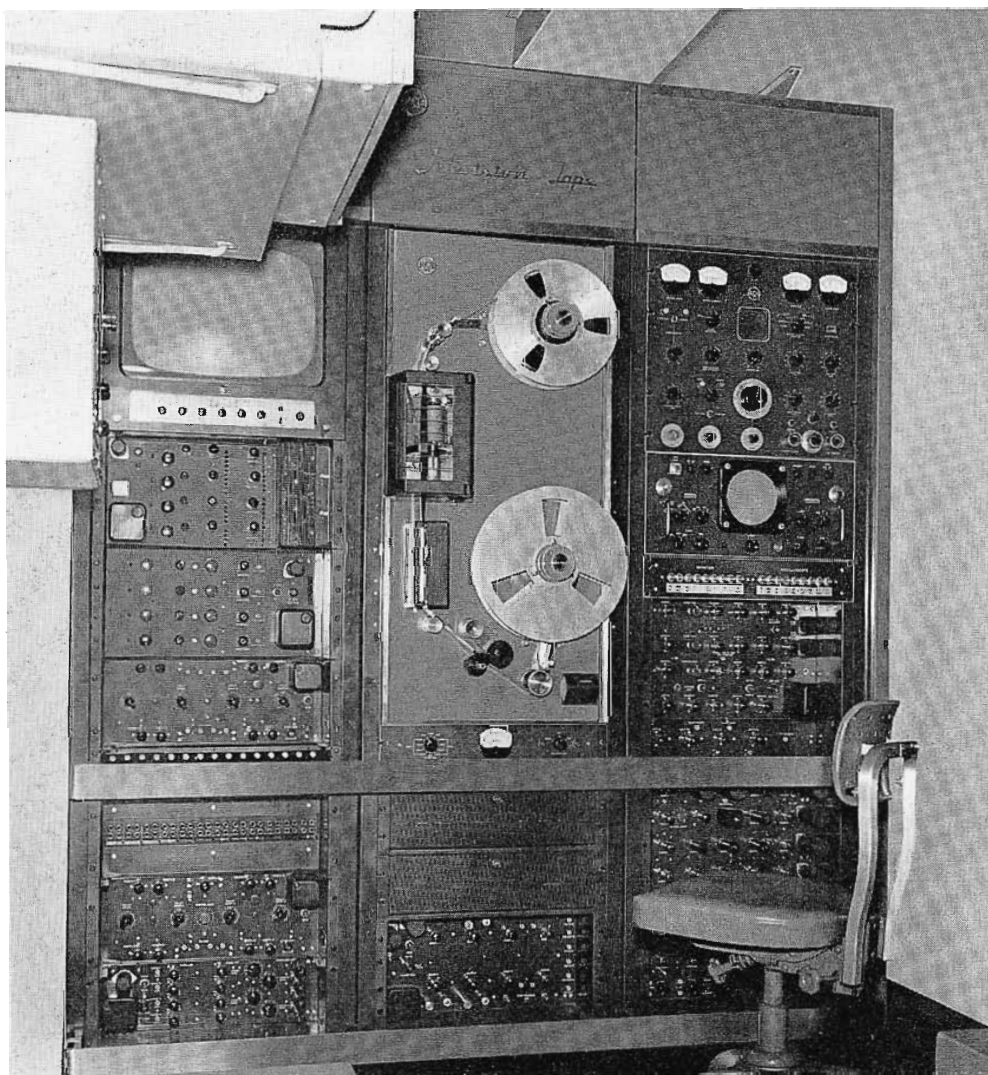





FIG. 1. Army Transportation School uses this TV Tape Mobile unit for spot pickups at widely separated points on the Ft. Eustis base. These pickups are then incorporated into the training program via closed circuit television.

## MOBILE RCA TV TAPE UNIT AIDS MILITARY TRAINING



Personnel attending the school conducted by the U.S. Army Transportation Training Command at Fort Eustis, Va., are learning about stevedoring, railroading, helicopter and auto repair with the help of a tv tape mobile unit.

The Army Transportation School employs a closed circuit tv system reaching all classrooms. Three tv cameras in the main studio permit live programming. A film room provides the source for slide and movie presentations. The system includes 22 classroom receivers.

A second mobile unit is equipped with two tv cameras and control equipment. It is used for pickups from maintenance, repair, and other work areas on the base. These spot pickups are tied into the system hook-up via tv tape.

FIG. 2. A complete, operating TV Tape Recorder is installed in the Ft. Eustis mobile unit. This view shows the three operating racks. Two auxiliary racks are farther forward.



# MERRILL TRAINER HEADS NEW DEPARTMENT

A special department has been formed by RCA to develop electronic recording instruments and high-power rf equipment. This will be part of the Broadcast and Television Equipment Division, headed by Mr. C. H. Colledge. The new Recording Products, High Power and Nucleonics Department is headed by Mr. M. A. Trainer.

The Recording Products group will develop a variety of electronic recording devices not only for broadcasting but also for data processing and other applications. Variations of the tv tape recorder are finding jobs to be performed in factory process control, in telemetering, in the missile and space programs, and in education.

The High Power and Nucleonics group will develop advanced types of transmitting equipment, including antennas, for the broadcast industry. A second function is application of high-power rf generating equipment to nucleonics and space programs.

Mr. Trainer is no stranger to the broadcast industry. He has been serving in many engineering and marketing capacities for the Broadcast Division. He joined RCA in 1930 and has played an important role in the engineering leading to the all-electronic television system that is in use today.

Mr. Trainer is a senior member of the I.R.E., a member of Tau Beta Pi, and the Franklin Institute. He has served on a number of important industry committees dealing with television broadcast problems.

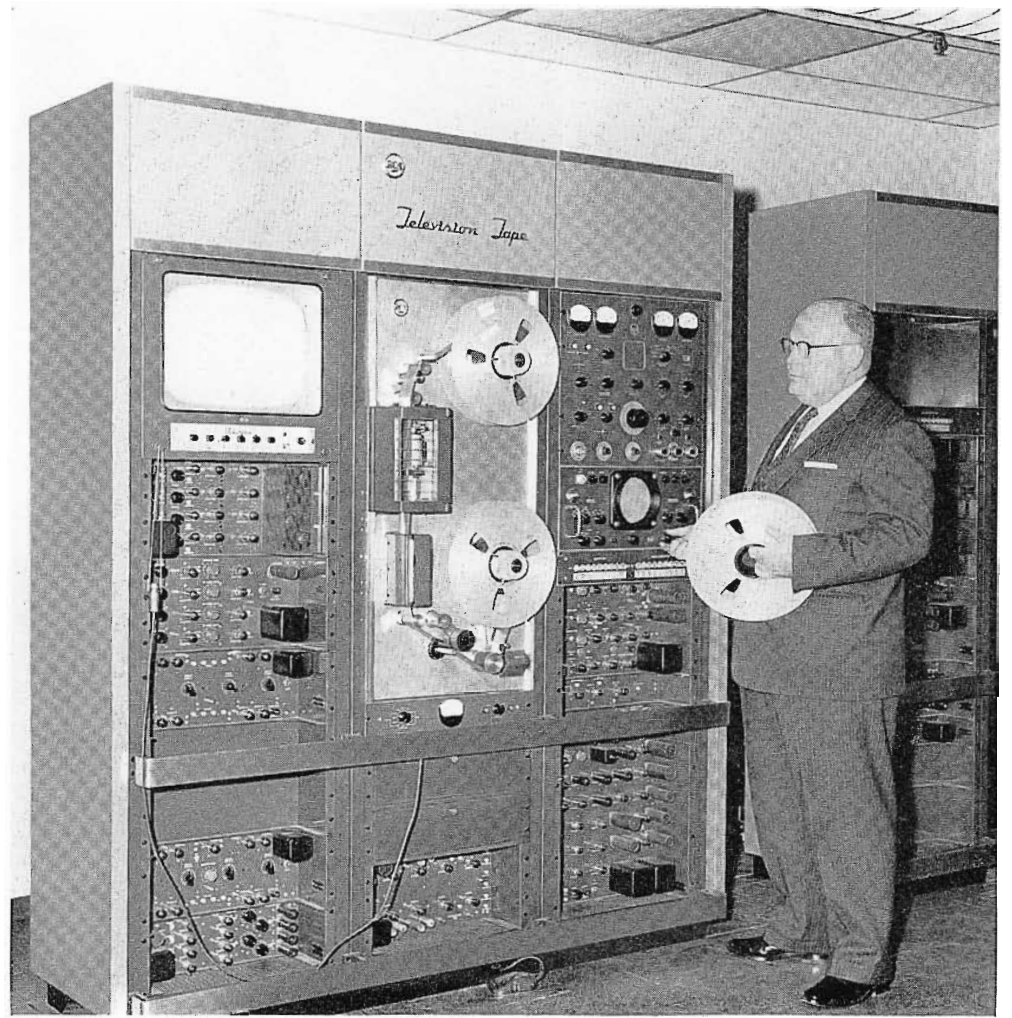

The tv tape mobile unit consists of a specially designed van. Space is provided for the complete tv tape recorder. Power control, air-conditioning, storage, and adequate work areas are provided.

Brigadier General Frederick D. Atkinson, Transportation School Commander, reports: "The mobile TV Tape Recorder is an extremely valuable addition to our educational aids. It will enable us to build up a library of instruction courses on a wide variety of transportation subjects. We can make pictures at widely scattered points on the Fort Eustis base. We can utilize to fullest advantage the talents of our top specialist in each field, with a permanent record of individual presentations available for classroom use when an instructor may be occupied with other duties."

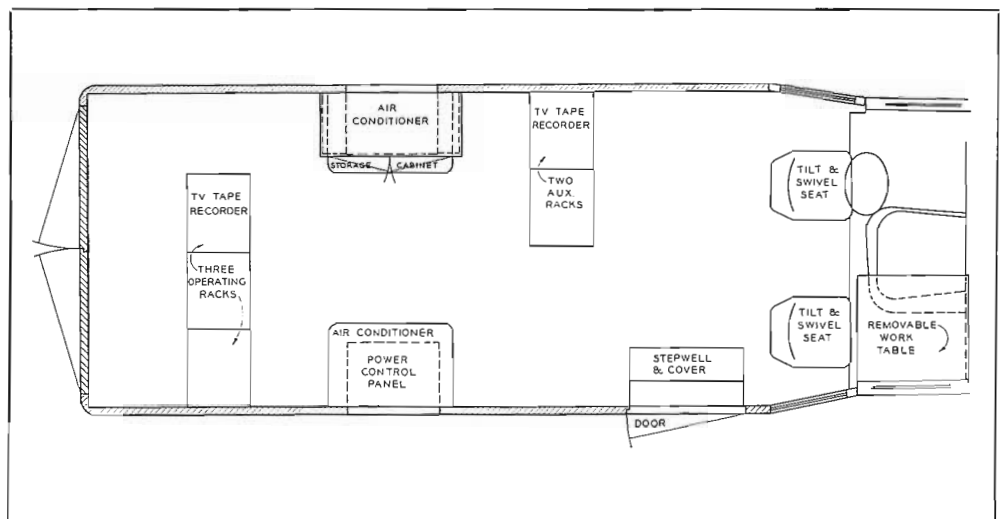

FIG. 3. Layout of Ft. Eustis TV Tape Mobile Unit. Note air conditioners, power control, and storage facilities. Ample operating area is included. Power is external — coming from any 110-volt source.



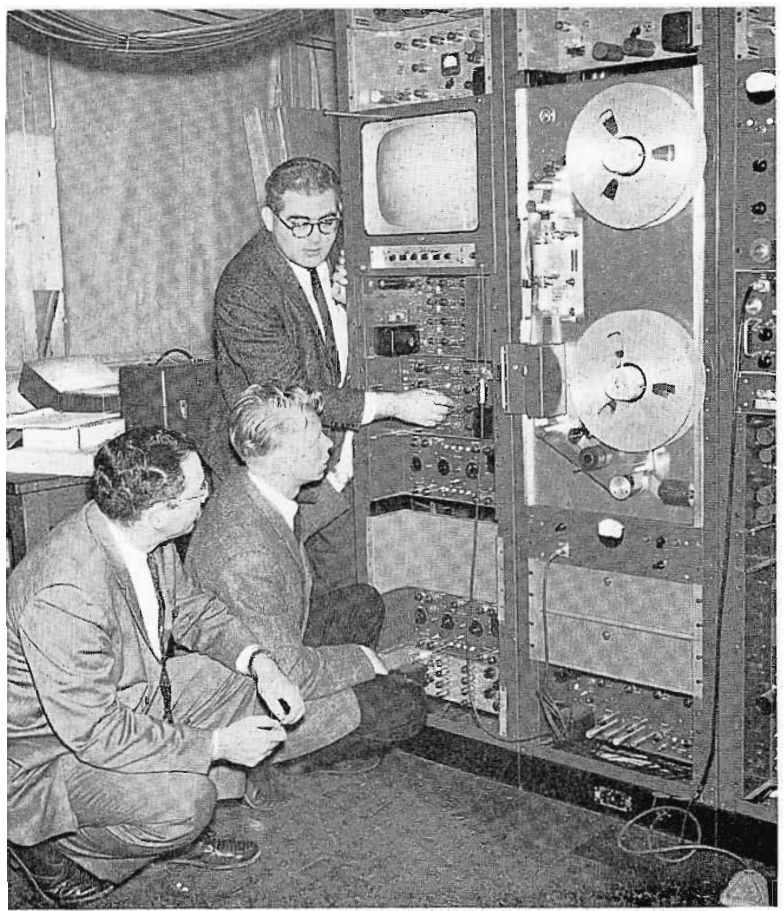

FIG. 1. First phases of Service Company training began with design and development of the TV tape recorder. Left to right, R. C. Gold, J. Hamalainen and J. M. Sampley examine engineering model.

## SERVICE COMPANY EXPANDS TV TAPE TRAINING PROGRAM

by EDWARD STANKO, *RCA Service Company*

The Broadcast industry has benefited through the years from talented program people, skilled engineers and capable management. Similarly, for the past 25 years, RCA field engineers have contributed to the development of the business through installation and service of broadcast equipment.

As the complexity of the equipment increases, broader uses unfold, and rarely in the history of this industry has so challenging an era been encountered as that of television tape recording. There have been very few electronic advancements that have caused as much interest among television station executives, producers, directors and engineers as the introduction of the RCA TV Tape Recorder.

During the development and design of TV Tape equipment, the RCA field service engineering staff maintained close contact with the designers in order to prepare for the installation and maintenance requirements. Planning of a training program with sufficient scope to provide skilled personnel on a nation wide basis was an obvious re-

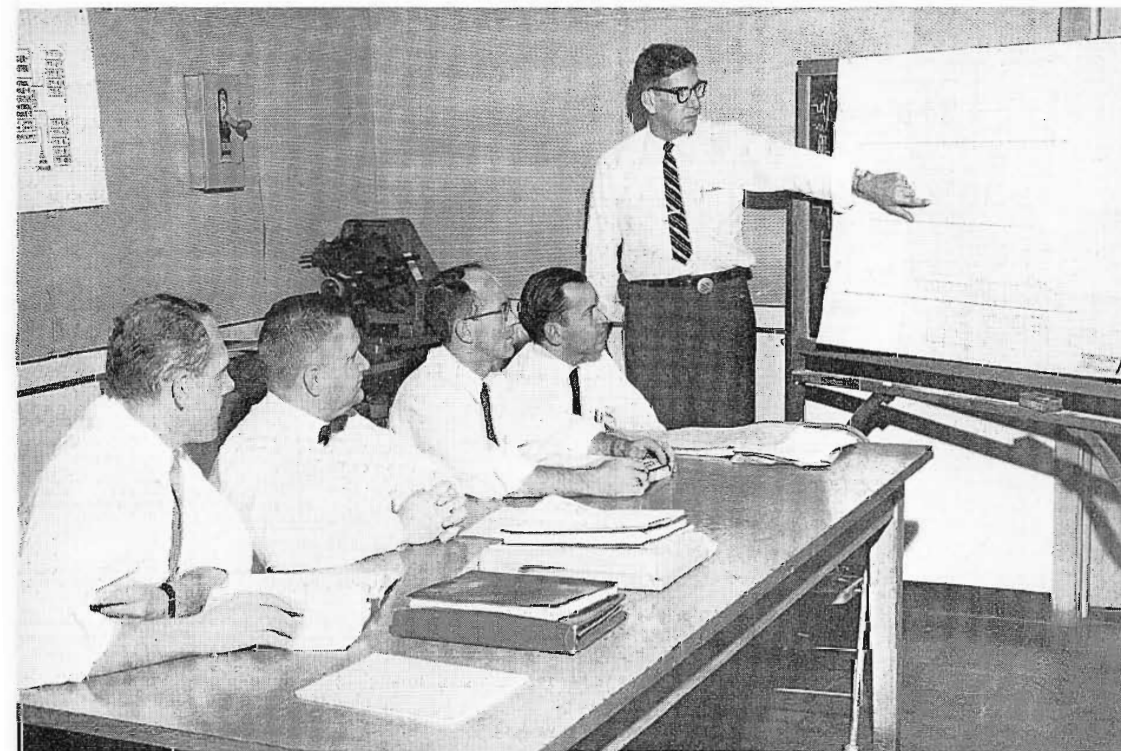

FIG. 2. Class in circuit theory is conducted by R. S. Koerner. J. Cimba, M. Payne, E. S. Clark and H. W. Dover are seated left to right.



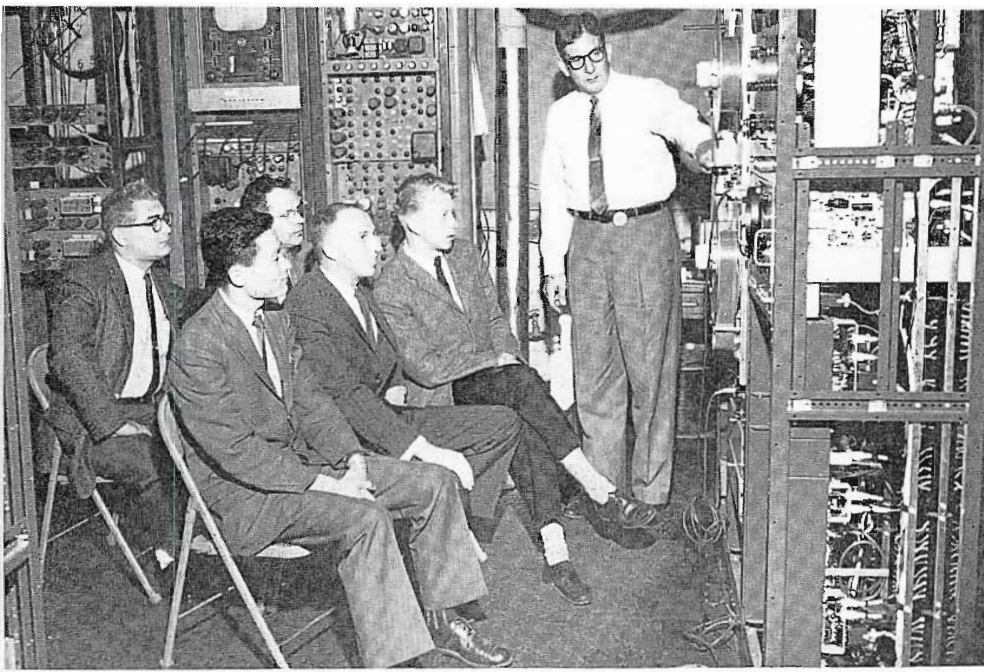

FIG. 3. Classes were kept small for maximum exchange of information. Here one of three separate courses is being conducted at the engineering laboratory in Camden.

quirement. Since new techniques and associated devices such as servo-mechanisms, recording heads rotating at 14,000 revolutions per minute, and other newly developed circuits previously not used in broadcast practice were utilized in achieving TV pictures from magnetic tape, it was apparent that it was necessary to provide on-the-spot factory training to the service people.

In cooperation with the Broadcast Service Field Managers, strategically located across the country, a large group of the field

engineering staff was selected to receive intensive training in television tape equipment and techniques. In order to maximize the exchange of information at informal training classes, it was decided to keep the classes as small as possible, therefore, three separate training courses were planned under the supervision of the author and R. S. Koerner. Engineers who received this training are located throughout the country and include representatives from Japan and Switzerland.

The training program included:

1. Introductory course of video recording on tape.
2. Circuit analysis of each chassis.
3. Individual studies of all schematics and drawings.
4. Study of mechanical tolerances and problems.
5. Complete system analysis.
6. Operation of engineering model and factory production units.
7. Test equipment requirements.
8. Test procedures.
9. Proper methods of maintenance and service.

Supplementing the factory training, each field engineer worked with the production people to become familiar with all phases of assembly and manufacture. The Engineering, Factory and Production training course was supplemented by a special program conducted at the National Broadcasting Company, New York, where the field engineers received the latest information on the production of television tapes. This phase of training included programming, recording, operation procedures and technical adjustment of the equipment for monochrome and color operation.

To date more than 16 RCA Service Engineers have received this thorough tv tape training. These men are located in each of the service areas throughout the country. They are trained and equipped to handle all phases of the specialized tv tape service.

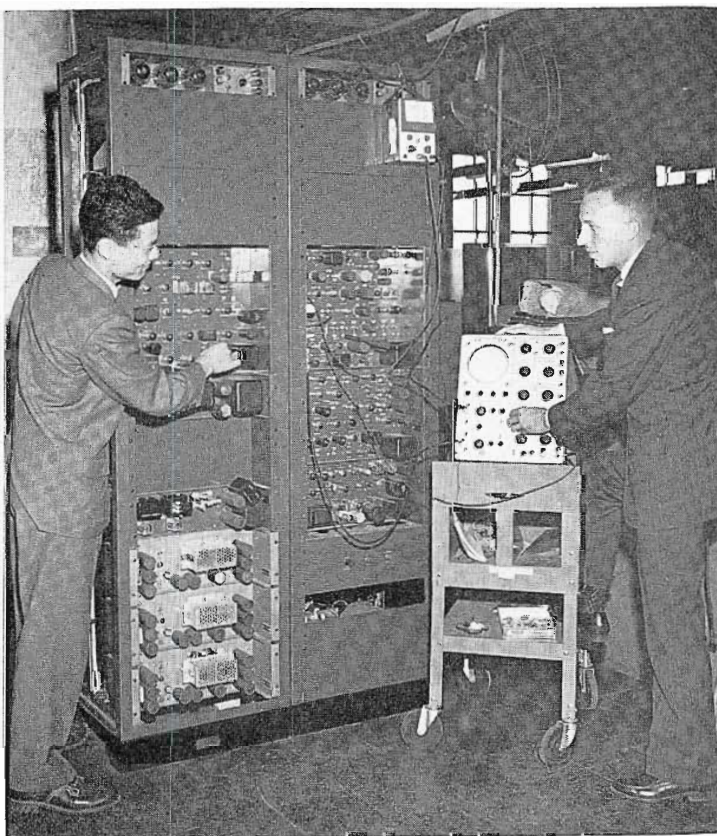

FIG. 4. Service engineers T. Kohmura and C. Power take over check-out and maintenance procedures during final sessions of the training course.

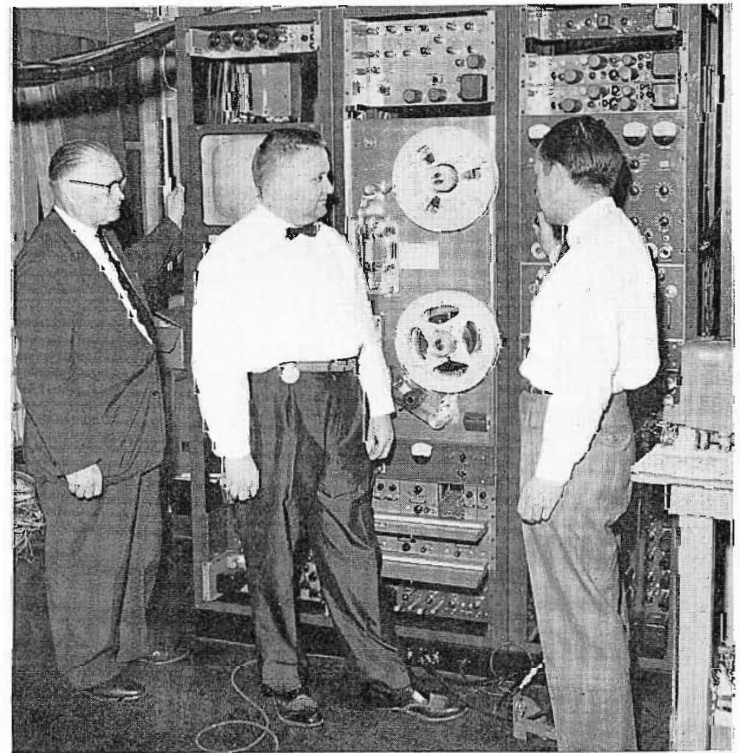
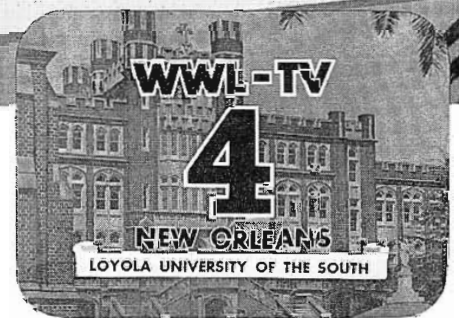

FIG. 5. The author (left) observes one of the many stages of the program. H. W. Dover (right) runs through set-up procedures for M. L. Payne (center).



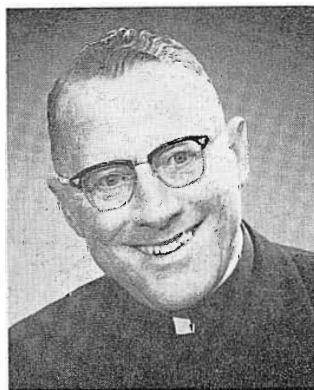

FIG. 1. Studio building of WWL-TV located in downtown New Orleans.



## HOW WWL-TV PLANNED A FORWARD-LOOKING INSTALLATION

by J. D. BLOOM,  
*Director of Engineering,  
 WWL-TV, Loyola University,  
 New Orleans, La*



Rev. A. B. Goodspeed, S. J., Faculty Director, WWL-TV. After ordination to the priesthood in 1931, he became a Professor at Loyola U. He was assistant to the New Orleans Provincial of the Society of Jesus from 1937 to 1943 and served as President of Jesuit High School from 1943 to 1948. He is treasurer and a member of the Board of Directors of Loyola U.



Mr. Lawrence M. Carino, Manager of WWL-TV. While at Columbia University, he was a studio manager at ABC. Upon graduation in 1949, he returned to his native Tacoma, Washington, joining KTNT. In 1956, he had risen to General Manager of KTNT AM and TV. He joined WWL-TV as Sales Manager in 1958, was named Manager in 1959.



Mr. J. D. Bloom, Director of Engineering for WWL-TV, began his radio career with WWL in 1924. After graduating with an AB degree from Loyola University in 1929, he attended the University of Detroit, where he was graduated in Electrical Engineering in 1932. He returned to New Orleans as Studio Supervisor and was made Chief Engineer in 1937.



Loyola University is the licensee and operator of WWL-TV, which went on the air September 1957. This Jesuit University has had a long history in radio. It first started with wireless communication in the Physics Department as early as 1907. Loyola opened the initial radio broadcasting station of the south-central United States in 1922. Station WWL-TV is the product of more than five years research, investigating 64 television stations throughout the nation, then incorporating their more desirable features.

The facilities of WWL-TV are housed in two principal locations. Largest of these is the studio and office building (see Fig. 1) located in downtown New Orleans, while the transmitter is located a few miles across the Mississippi River near the city of Gretna. Contemporary, functional styling predominates in both structures.

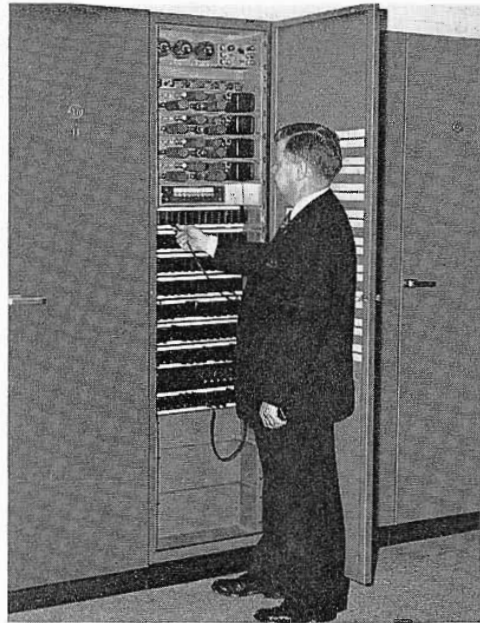

FIG. 2. Dan F. Hynes, chief engineer of video facilities is shown at the video distribution patch panel, which he designed and built for WWL-TV.

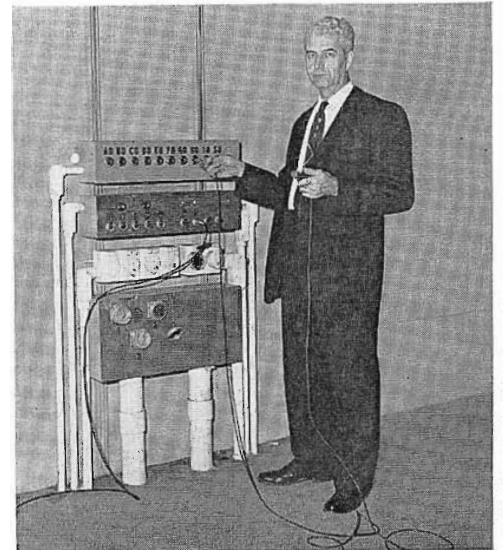

FIG. 3. Francis Jacob, Jr., chief engineer of audio facilities, at one of four termination panels in studio. Each contains 10 microphone, 9 audio and 2 video outlets; 2 intercom system, and 3 camera outlets. Conduit is in place for 3 more camera cables for color cameras.

### Studio Philosophy

The WWL-TV studio is unusually large, well planned, and designed for expansion. It is 100 feet long by 45 feet wide. It is

furnished with dual facilities so that it can be divided into two 50-foot long studios in the event of future expansion.

In planning, the main objective was to eliminate all messy, trailing cables from the studio floor. This has been accomplished by



FIG. 4. WWL-TV studio. This 7000-square-foot area has three camera outlets at each of four stations. The one in the ceiling, shown here, has proven the most useful. Two trolleys bisect the studio to keep camera and microphone

cables off floor. The studio is provided with 72 microphone outlets situated at 8 locations, terminating at the studio audio console. Studio facilities, including air conditioning and lighting, are adequate for color programming.



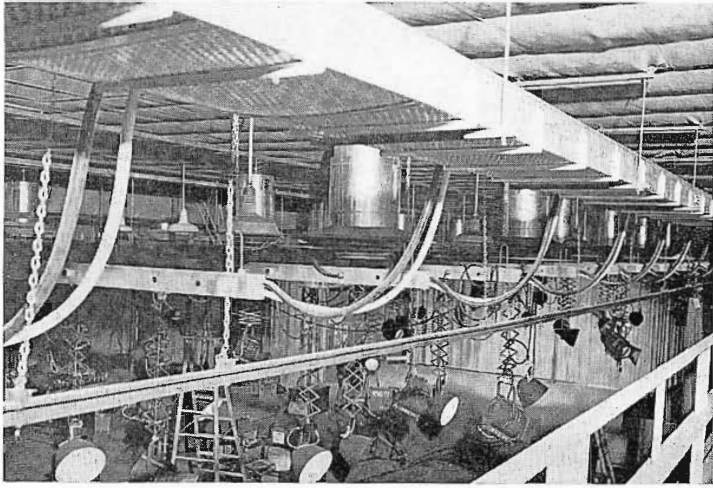

FIG. 5. View of light battens hung by chain from power-strut channel. Battens, which average 25-ft. in length, contain 6 20-amp. receptacles and 4 50-amp. receptacles with channel for hanging fixtures. The fiberglass acoustical treatment, as seen in this photo, is covered by fiberglass screen. Note flexible cables to permit batten movement.

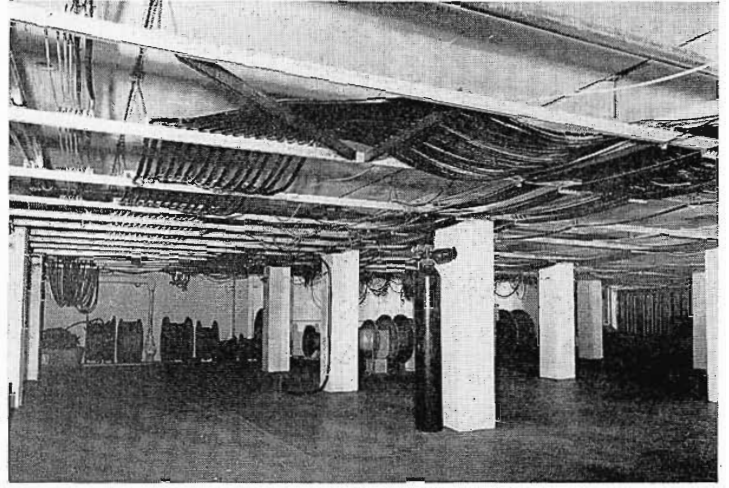

FIG. 6. The wiring vault beneath master control. Utilizing the 5-foot elevation of master control room, the suspension of a power-strut grid permits easy addition or removal of cables and video lines, without disturbing existing wiring. Note the absence of cable trays or raceways. Ten-inch holes under each piece of equipment provides cable access and permits exhausting of filtered, cool studio air through equipment racks.

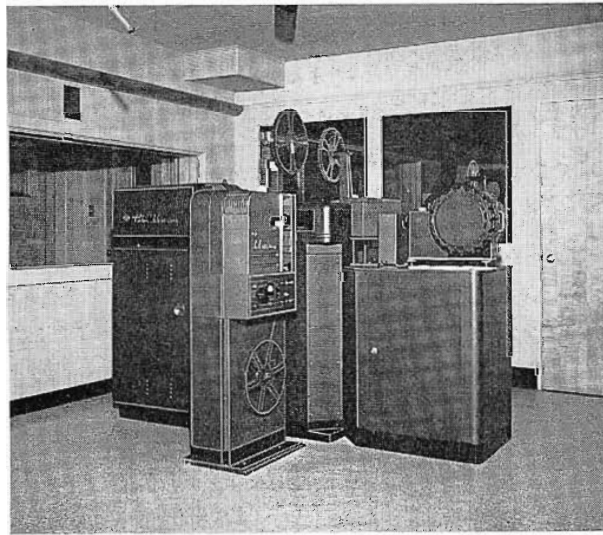

FIG. 7. Projection room with two TP-6CC Film Projectors, a TP-7 Slide Projector, a TP-15 Multiplexer, a 1-V Vidicon Film Camera and a 3-VColor Film Camera. Space left for a duplicate of this set-up is now in process of having equipment installed. (Access holes in floor for this expansion were plugged at the time that this picture was taken).

FIG. 8. Production control room. Elevated 5 feet above the studio floor, the director utilizes a row of TM-7 Monitors for program sources. The lighting control board (described elsewhere) is to the right of the switching desk, and the announce booth to the left. Three systems of intercom are available to the director: the push button type which includes the lounge, property storage and announcer's office as well as operating areas, the microphone ceiling speaker system and the standard headset type. (The latter two are tied together). This method of operation with the video and audio control personnel separated from the director has proven very satisfactory.

using an overhead system. Camera and microphone cables are brought down from the ceiling. They operate on trolleys, which run on two tracks, suspended the length of the studio (see Fig. 4). Also, microphone and audio utility panels are located at four places in the ceiling. (In addition, camera, microphone, and audio utility outlets are located in three places on the studio wall.)

An efficient overhead lighting system has been designed, using aluminum battens. They house all wiring, contain the outlets, and support the fixture hangers. Battens are hung by chain from Power-Strut channel, fastened to the ceiling (see Fig. 5). (Lighting control is removed from the studio floor).

A 3-foot false ceiling has been constructed, finished with a concrete slab on top and fiber glass on the under side that forms the studio ceiling. This acoustical treatment serves two purposes: It keeps sound reverberations in the studio under control, and it filters out noise of the frequent New Orleans thunderstorms as well as low flying aircraft. Side walls of the studio are formed of brick with no acoustical treatment except for covering of final three feet near ceiling with fiber glass.

#### Designed for Expansion

WWL-TV has already profited from the foresight that led to planning for 100 percent expansion. In the control area, this has provided sufficient space for installation of two video tape recorders. As live programming requirements grow, the 100-foot long studio can be divided into two with separate air conditioning and technical facilities. Each of these studios will have camera cabling, microphone and audio outlets already installed. Sufficient area and wiring







FIG. 9. Master control position with J. R. Lawton, Jr., master control supervisor, at video controls, and R. C. Warren at switching position. On the left are three TK-11 Camera Control Units, a TK-21 Control Unit, TM-21 Color Monitor, the TK-26 Controls and Master Monitor. At the switching position five consoles are used; the first, Remote Controls for two TA-21 AGC Amplifiers, a TA-9 stab amp, the TP-15 Multiplexer and variable density light filters. The next two house the preview and line TM-7 Master Monitors. The table in front of these units contains controls for the master control TS-21 Relay Switcher. In the fourth console is the master control audio switcher, designed and constructed by the WWL-TV Engineering Department. The fifth is used for telephone and intercom facilities with an audio tape recorder on the extreme right. The shelf (extreme right) has three monitors; one for network as received from telephone company, another microwave output, and the third "off-air" monitor. To the left of this area is the projection room and straight ahead is production control room with view of studio beyond.

space are available for the second control room. The lighting system can handle 250 KW but only 100-150 KW of this is now required for monochrome. The remainder is available for color. Provisions are made for four live and two film color camera installations. In the film room just recently there was added a second chain, complete with two film and one slide projector (this in addition to the 3-V color film system already installed, see Fig. 7).

#### Separate Production Control

Separate areas for technical personnel and for production personnel make the plant run smoothly. Thus, the director, agency, and client can congregate in the production room directly in front of the studio window (see Fig. 8). Here are switchers and monitors. Directly behind is master control, with duplicate switching facilities, overlooking production control and studio (see Fig. 9). This cuts out all interference between technical and production people.

According to this philosophy, video and audio engineers are likewise in separate areas (see Fig. 10). Between them the announcer is located. He can look into both video and audio areas, as well as into the studio. Also he has his separate on-air monitor. This places the scripts in one central location at all times.

Lighting control is not on the studio floor but is located in the production control room (see Fig. 11). Here the operator has an excellent view of monitors to check results. He is neither hidden behind some sets nor does he have a pile of stuff stored around his control equipment. His portion of the studio window is higher in order to be able to see lighting fixtures.

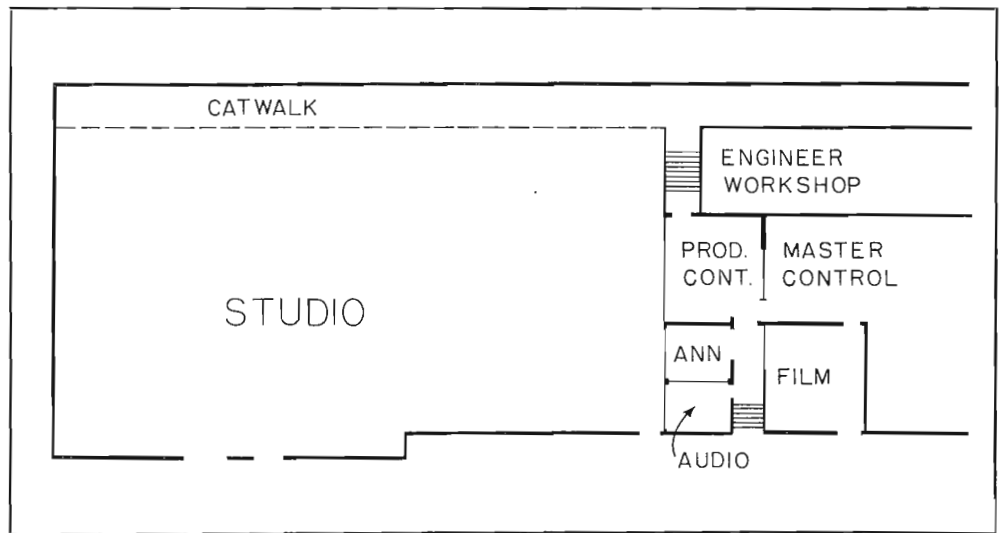

FIG. 10. First floor plan of WWL-TV studio building, showing how the technical facilities are arranged. Note that Production Control and Master Control are separated. This gives the technical personnel an area of their own in which to operate, without distraction. Likewise, the director, agency, and client can have privacy in their own area. Also, video and audio engineers are separated. The Announcer is located between Production Control and Audio. The Film room is directly behind Audio and Announcer. Under this arrangement, all can see into the other's area, and all can see into the studio.

FIG. 11. Tony Maggiore, supervisor of camera and lighting is shown operating the Aerial-Davis lighting board located in production control. Panel to right is Quick Connect Board which can handle 120 20-amp. circuits with no patch cords. Sloping panel to left has 21 dimming circuits. Circuit breakers and transfer switches are directly below dimmers and 72 50-amp. patch circuits are here at knee height. Total capacity of equipment is 200 kw.

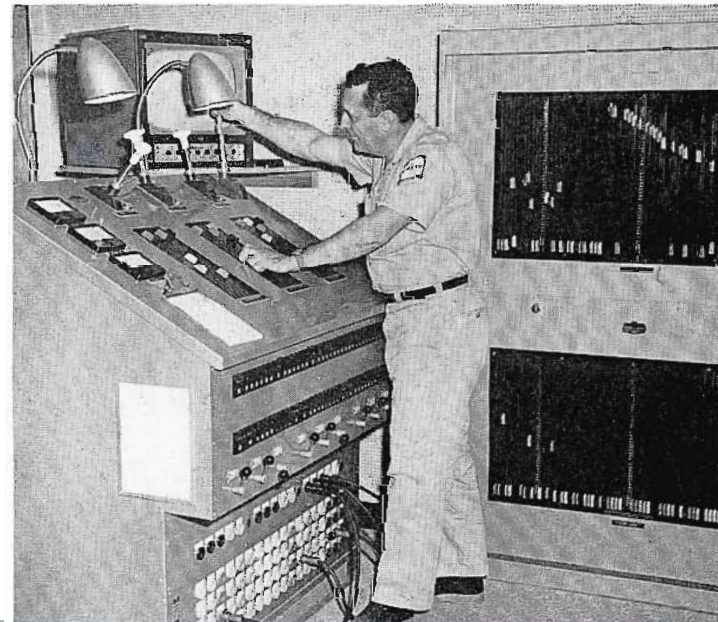





FIG. 12. Path of microwave transmission at WWL-TV runs from studio at upper right, under Mississippi River bridge, to transmitter (beyond picture at extreme left).

## UNIQUE MICROWAVE LINKS WWL-TV STUDIO WITH TRANSMITTER

### Rack Mounted System

A four-mile hop from studio to transmitter is covered by a TVM-1A Microwave system with 100 percent standby. All equipment is installed in racks so that operation and maintenance are under better control. Removal of head units from behind the antenna (where they are frequently installed)

meant that 100 feet of waveguide had to be installed at the studio terminal. However, this pays off, since equipment can be kept under surveillance and operated at peak efficiency at all times. Outdoor maintenance with its attendant weather problems becomes a thing of the past.

### 100 Percent Standby

A complete standby system is installed. Since this is a one-way link, there are two microwave transmitter installations at the studio and two microwave receiver installations at the TV transmitter. Also, there are two antenna systems, complete with waveguide feed at each terminal. Daily alter-

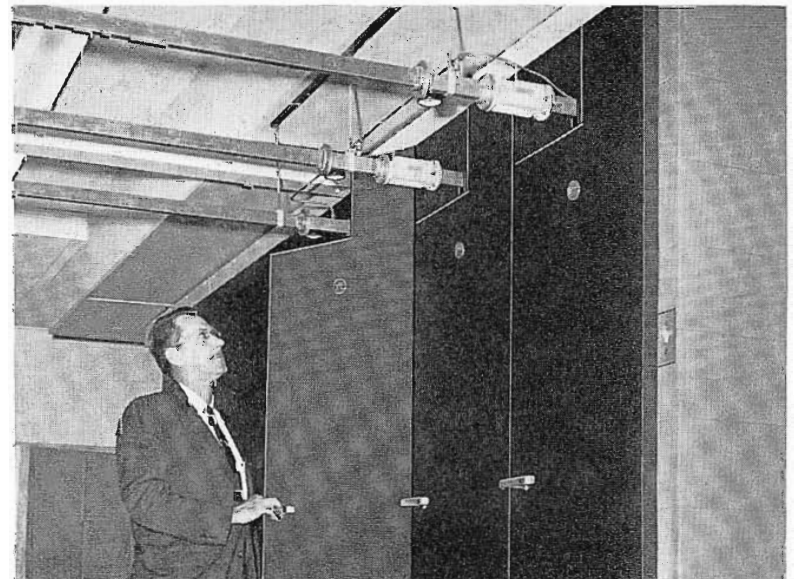
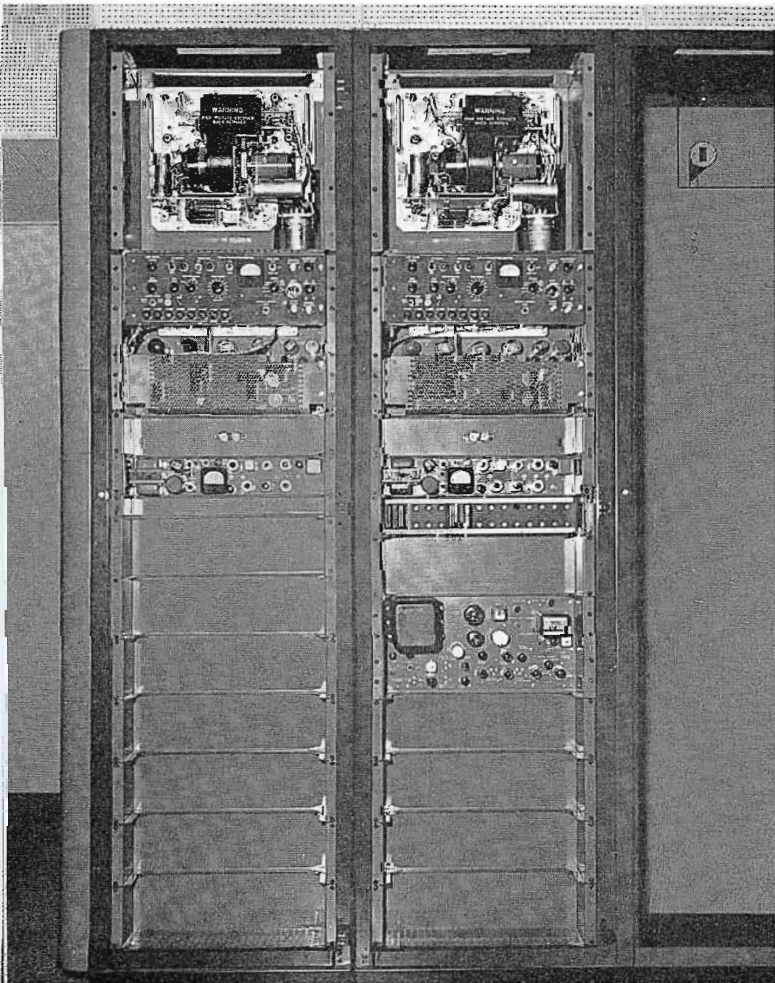

FIG. 14. Frederick J. Fabre, maintenance supervisor, demonstrating cut rack door, allowing waveguide to emerge from standard RCA cabinet rack. (This was designed by WWL staff).

FIG. 13. Microwave transmitters in studio racks. Top to bottom are Microwave heads, (feeding 96 ft. of waveguide and 6-ft. dishes on tower above building), transmitter control panel and power supply, sound diplexer, and patch panels (audio and video). Unit in second rack is stripe generator. (Third rack is for link with future mobile unit).





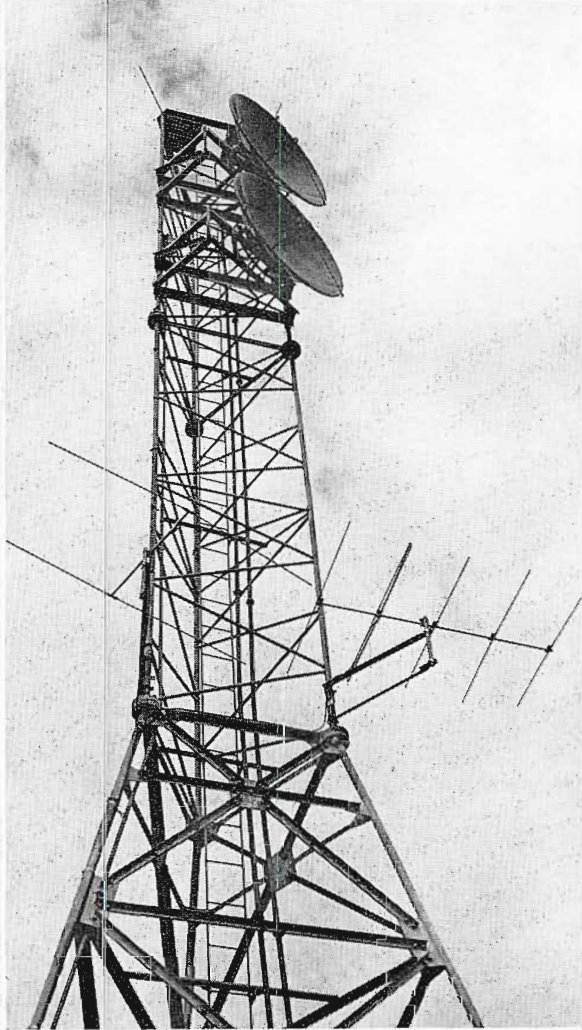

FIG. 15. Tower atop studio building shows mounts for microwave dishes, (also receiving antennas for office monitoring system). This tower is 67 feet high, (90 feet above street or sea level).



FIG. 16. WWL-TV Transmitter, near city of Gretna some five miles from downtown New Orleans studio, is housed in a modern brick and concrete building of windowless design. Unusual feature is placement of air circulating

and conditioning equipment on first level — outside the working area — eliminating principal source of noise. Note passive microwave reflector on tower, 92 feet from ground level. Note also microwave dishes on roof of building.

nation of regular and standby links keep the system in top operating condition.

#### Ducks Under Mississippi Bridge

Shortly after this microwave link was planned, a serious problem arose. It was discovered that the new Mississippi River Bridge would be located directly in the path of the microwave beam. After careful study, it was decided that the beam could be aimed beneath the bridge but still be sufficiently high to clear superstructure of ships. Accordingly, the line of sight was established between the bridge roadway and the surface of the water, (see Fig. 12).

Studio terminal has a 67-foot tower mounted on the roof which places microwave antennas some 90 feet above street level (sea level). At the TV transmitter, the microwave reflector is mounted at the 92-foot point on the tower. The bridge roadway is 150 feet above high water (slightly more than sea level). Thus, there is sufficient clearance (90-95 feet) above the water and under the bridge (55-60 feet) to give interference-free operation.

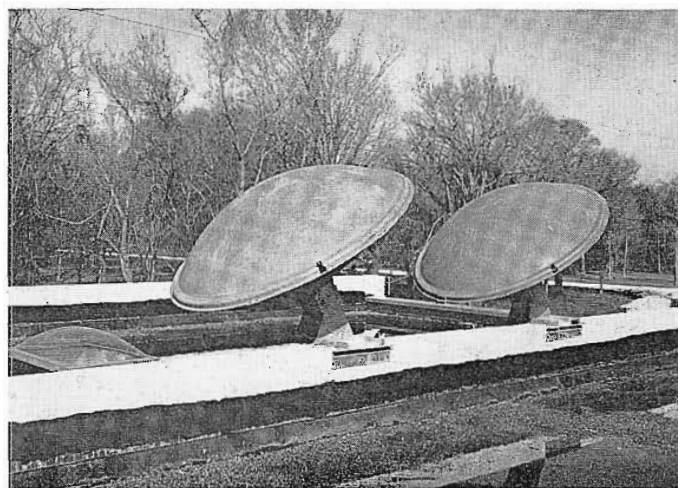

FIG. 17. Front view of microwave dishes mounted on roof of transmitter building. (Note protective plastic covers on dishes).

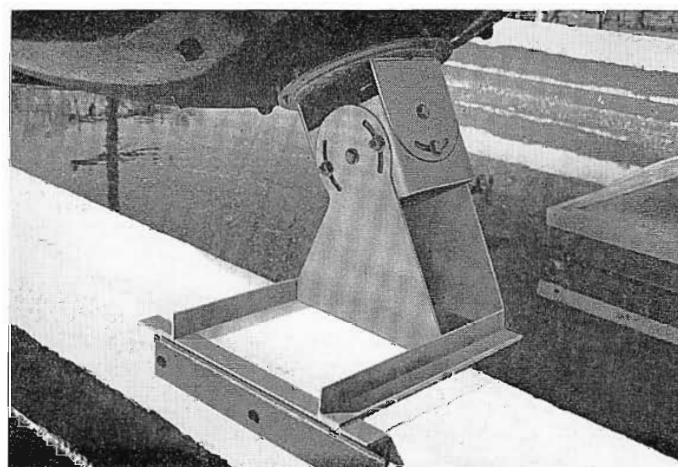

FIG. 18. Close-up of special mount designed to fasten dishes on concrete beam of transmitter building roof. Note provision for universal adjustment.



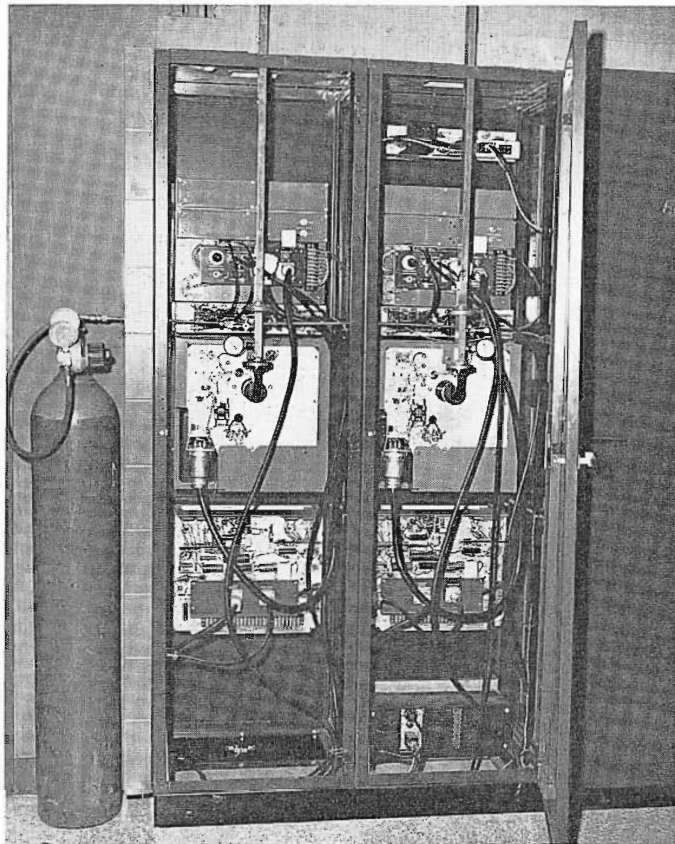

FIG. 19. Rear view, microwave receivers at transmitter.

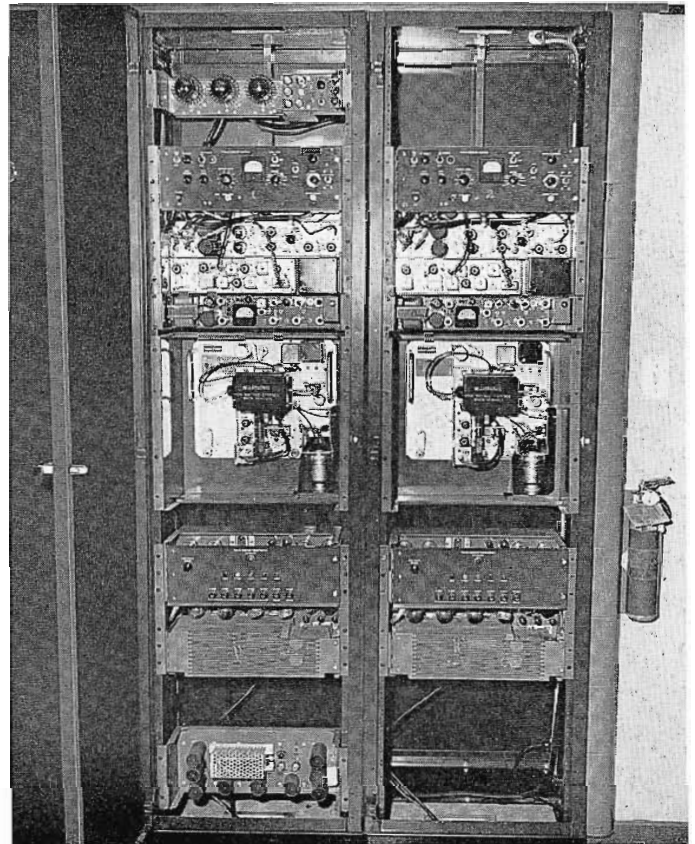

FIG. 20. Front view microwave receivers in transmitter building. Top to bottom are: Receiver control panel and demodulator, sound demodulator, receiver head proper (fed by waveguide from dishes on roof) and power supplies.

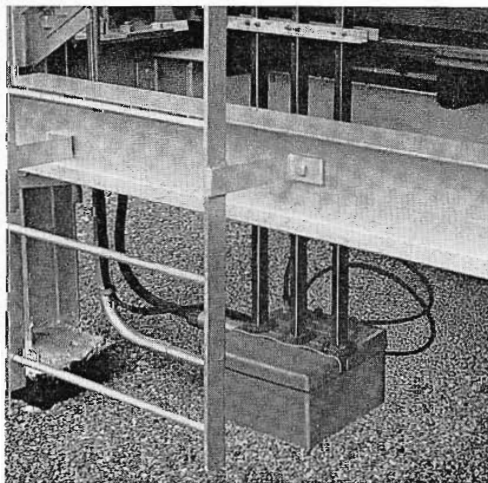

FIG. 21. Waveguides and communication circuits pass through special flashing on roof of studio building.

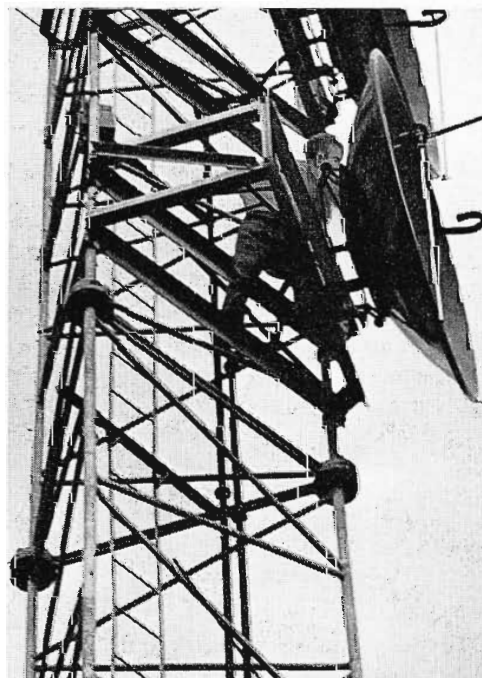

FIG. 22. Engineer lining up microwave dish by means of sighting tube placed on top of it.

### Perfect Record of Reliability

Many factors have contributed to the WWL-TV perfect service record with its microwave system. First, there are two separate power feeds to choose from. All the equipment is rack mounted, hence, can be serviced easily. Standby, including separate antenna systems, is always available. Power into racks is divided into three separate circuits to facilitate transfer to standby. Intercommunication is everywhere — even up to the top of the tower!

### Link With Mobile Unit

Since the station plans to procure a mobile TV unit, provision has been made to link it with the studio via microwave. Rack space for the equipment is arranged and waveguide has been run up the studio tower. It only remains to mount another dish on the tower and install a microwave receiver in the rack. In order to make contact with a mobile unit, a movable microwave antenna with universal waveguide coupling is required. This has already been designed by RCA for installation on the WWL-TV studio tower.



## WWL-TV TRANSMITTER

In designing this television station, the Engineering Department had a definite plan in mind for the transmitter as well as the studio. With regard to the transmitter it had been learned from visits to other stations that air noise was one of the largest problems. Accordingly, by using a raised building, all of the blowers were placed in a basement, which reduced the air noise on the operating floor to a bare minimum, thereby increasing the efficiency of the men on duty. Another interesting fact was that this building was made of prestressed concrete, so that the entire frame, including roof and floor, was assembled in only three days, in spite of inclement weather and very muddy working conditions.

### Pre-Fab Concrete Building

Methods employed in this unique construction job were perfected by a local firm, Belden Concrete Products. Integral pieces for the transmitter building were fabricated at the Belden plant while foundation piles were being driven at the transmitter site. The huge concrete beams were then trucked across the Mississippi River.

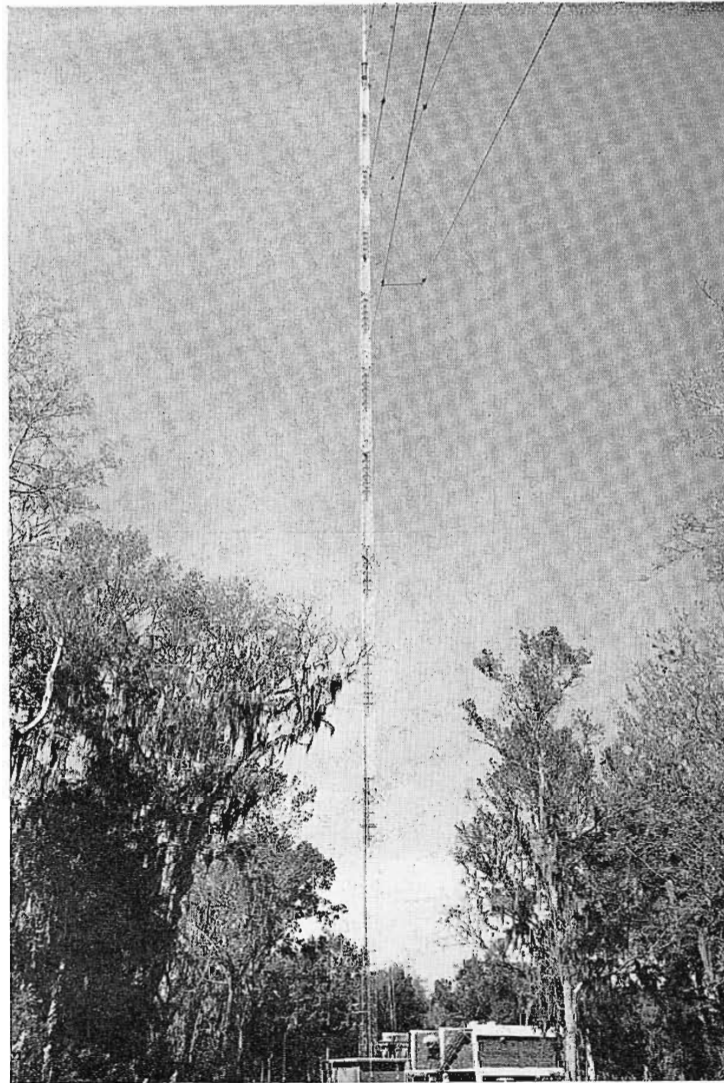

FIG. 23. Transmitter and tower of WWL-TV located in city of Gretna, a few miles from downtown New Orleans.

FIG. 24. Blower room. Located immediately below the transmitters to reduce noise in the transmitting room. Air ducts from the two "precipitrons" are seen in the right wall. Wiring trays are suspended from the ceiling, and transmitter blowers on pedestals.

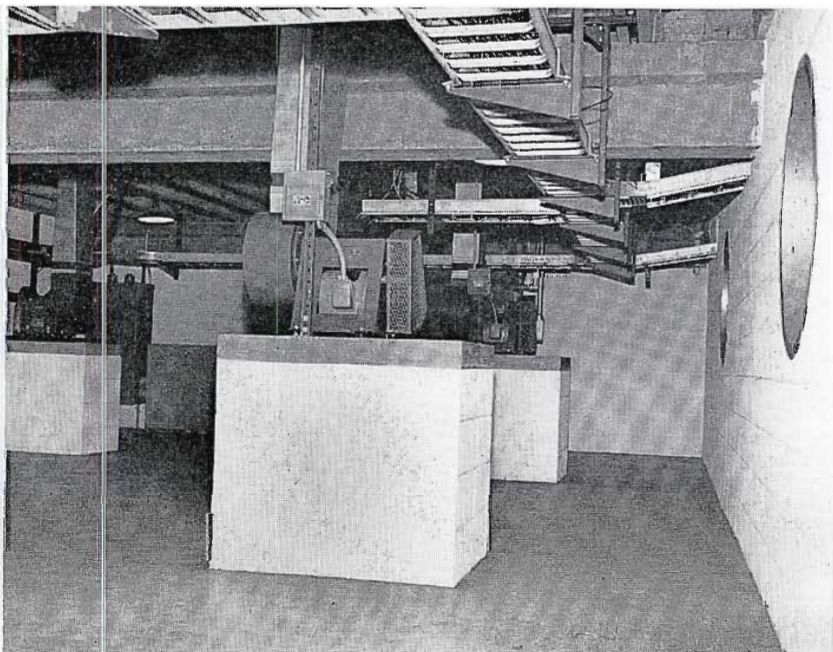
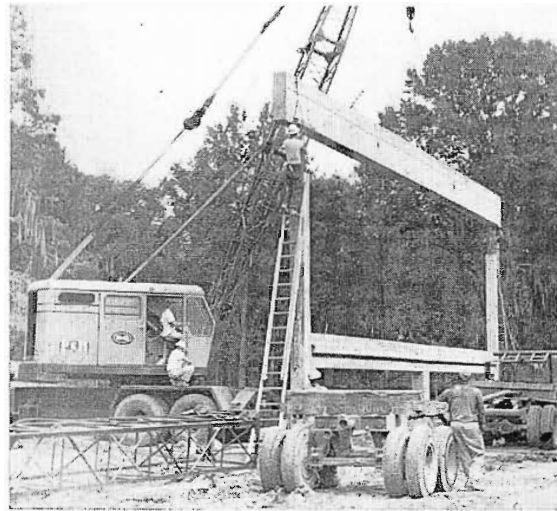

FIG. 25. Close-up of WWL-TV transmitter building and tower showing microwave passive reflector on tower. Microwave dishes are mounted on roof.





FIG. 26. Installing the first of four 14-ton prestressed concrete beams, which allowed an unobstructed floor area of 50 by 60 ft. In spite of inclement weather the prestressed concrete building was assembled in three days.



A nine-man crew, consisting of crane operator, six iron workers and a superintendent placed the beams in position. Lift crane was capable of picking up a weight in excess of 15 tons. This was the approximate tonnage of each of the four main concrete beams for the roof of the building.

In exactly three days the concrete work was completed. All that remained was to add the brick facing, insulation and inner walls; electrical, plumbing, and ventilating work. This was done while transmitter, tower and antenna were being installed. Outer dimensions of the building measure 61 by 53 feet, providing in excess of 6000 square feet on two floor levels.

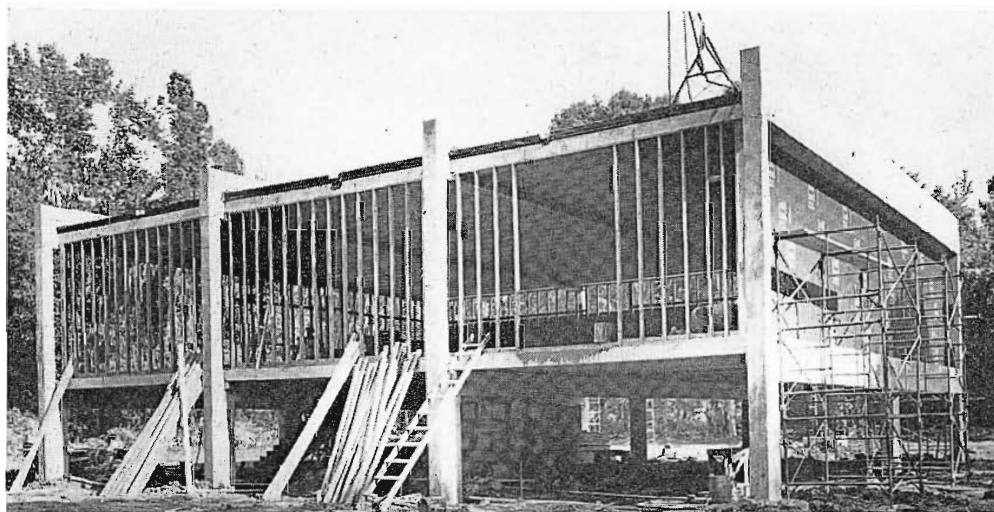

FIG. 27. Enclosing the pre-cast concrete frame prior to laying the brick veneer exterior.

#### Floor Trenches Avoided

In both the transmitter and studio equipment areas, floor trenches were avoided by using the space underneath as wiring areas. This resulted in a much neater looking floor. Air is exhausted through all of the equipment, (both at the transmitter and studio), in order to maintain the components at a more even temperature, as well as reduce air conditioning load (see Fig. 22). Air ducts also carry wiring into the transmitter racks.

Air entering the incoming ducts is first passed through Precipitron electronic filters, then pumped into the transmitter racks.

FIG. 28. Transmitter room. The TT-6AL on the left is the Auxiliary Transmitter, while the one on the right is used as the driver for the TT-25CL Transmitter. The visual control and rectifier units are seen on the end. The duplicate aural units are located to the left of the auxiliary transmitter. The 25 kw amplifiers are located behind the enclosure. Mr. Jos. E. Gros is seated at the console.

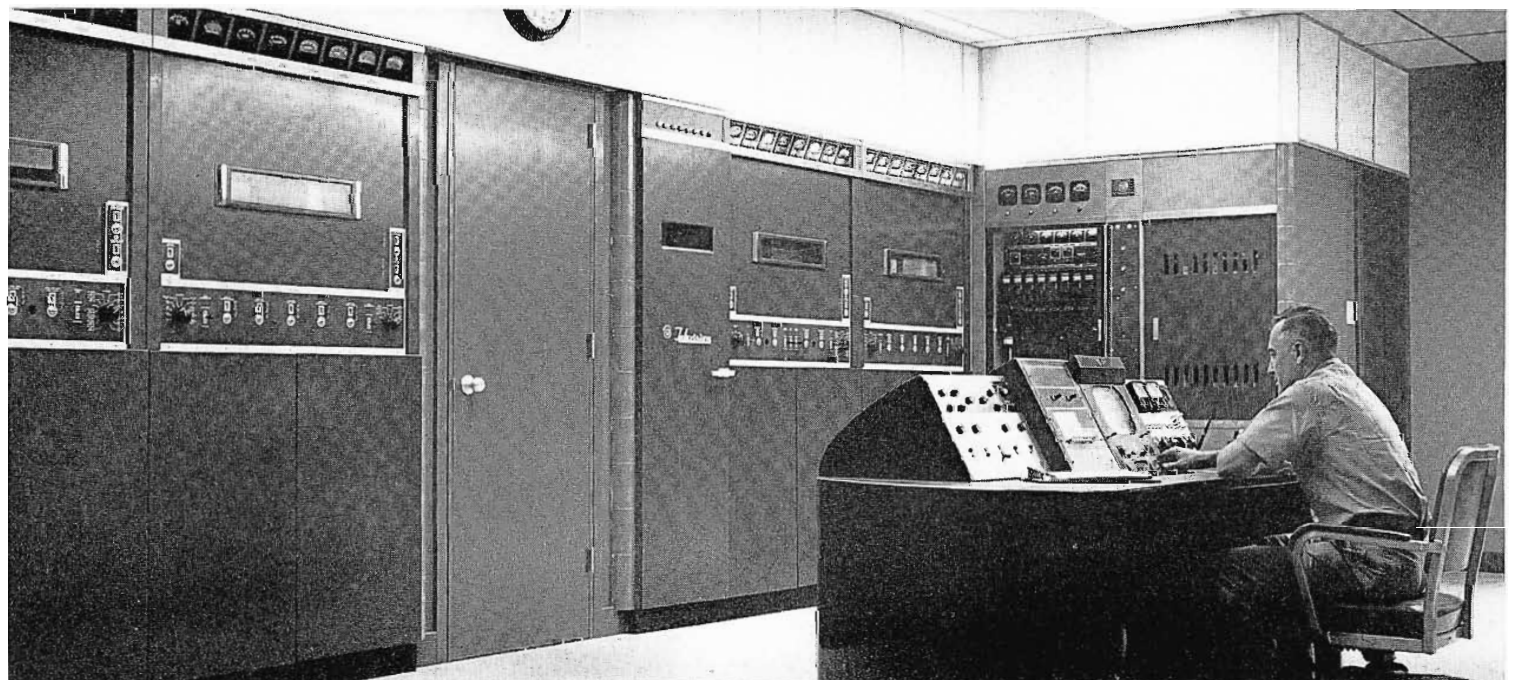



At the same time another pump exhausts the used air from the top of the racks. For efficiency, the air cooling is divided into two separate units, only one of which is used in cooler weather.

#### Standby Transmitter

A Type TT-25CL 25-KW TV Transmitter is employed in conjunction with a 6-KW standby transmitter. Two TT-6AL TV Transmitters are housed in the building, side by side. One is the driver for the main transmitter, the other is for emergency use. Each TT-6AL transmitter can be switched to feed either the 25-KW amplifier or the antenna. This affords convenience in maintenance of the equipment.

A Type TF-6BM 6-bay Superturnstile Antenna is used. It has a specially tailored vertical pattern to provide null fill-in. This provides for high quality reception in the immediate vicinity of the transmitter.

The 750-foot tower supports the TV antenna, the Microwave passive reflector for the STL link, and also acts as AM radiator for a neighboring radio station. (In principle this is similar to a shunt-fed radiator—sometimes called Unipole).

#### Video Tape Facilities

Because of the intense interest in this subject, agencies and clients alike prefer TV tape commercials to either film or live. They frequently desire to have filmed commercials recorded on tape. Therefore, WWL is now equipped with two tv recorders.

A single machine is neither practical nor economical. It doesn't make sense to have as much as \$10,000 worth of commercials hanging on a single machine over a weekend—without a back-up unit in case of emergency. Further, WWL could not fulfill all requests for tape recording because the one machine was frequently tied up for playing.

The station experimented with one tape recorder for a period of six months. During this time WWL used the machine an average of 15 hours per week. With the second, it is expected to increase tv tape usage by one third. This includes both record and play time.

#### Color Television

This station has planned for inclusion of complete color facilities from its inception two years ago. At the present time there is installed a complete 3-V color film system to handle color films and slides. Two local half-hour film programs are broadcast weekly, in addition to network (CBS) color

programming. Provision has been made for lighting of eight color sets for live shows from the studio. Cabling, power, and control facilities have been provided for four monochrome and two color TV cameras. Another 3-V color film camera may be added to the film room. As sets in use and network programming increase, WWL color operations will expand correspondingly.

Station management is quite pleased with this installation because after two years of

operation it has been found that no major changes would even be desirable. The efficiency of operation with both audio and video men removed from the Production Control Room has brought about very satisfactory results. Maintenance has not been a serious problem, and the outage record so far has been excellent. Finally, WWL-TV is fully equipped for present requirements and fully prepared for expansion in the foreseeable future.

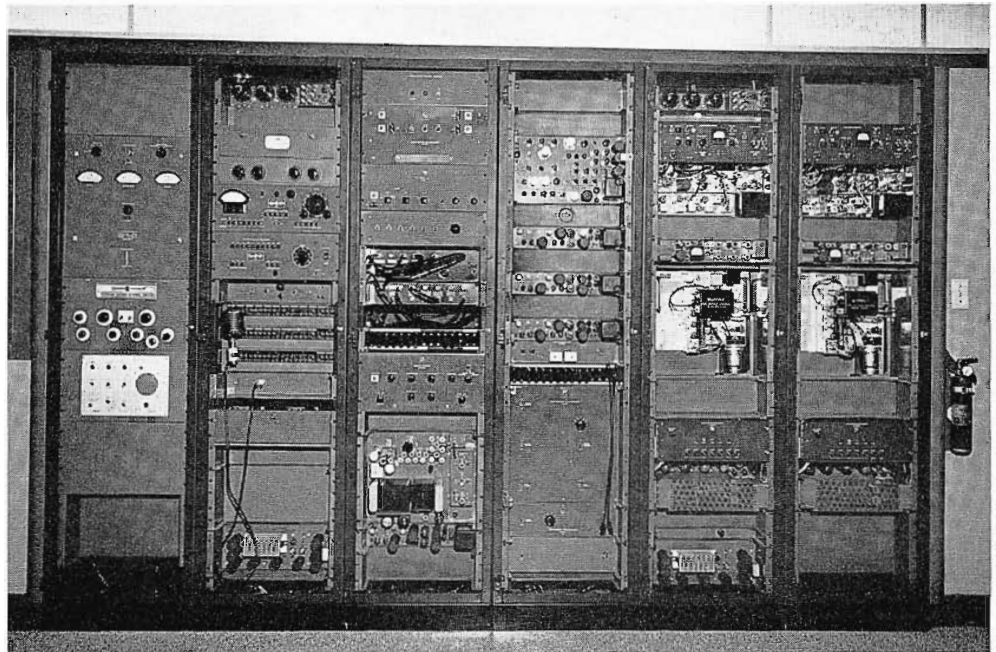

FIG. 29. Rack equipment, left to right are shown: BW-5A Frequency Monitors, a Conelrad receiver, audio input and test, video test, composite r.f. patch panel, demodulator, video input and equalizers, and microwave receivers.



Fig. 30. The motor driven coaxial switches mounted on rear wall are to switch the TT-25CL (or the TT-6AL Auxiliary) to the antenna. The manually operated coax switches are used to interchange the two TT-6AL's as drivers and to connect the transmitters to the dummy loads.



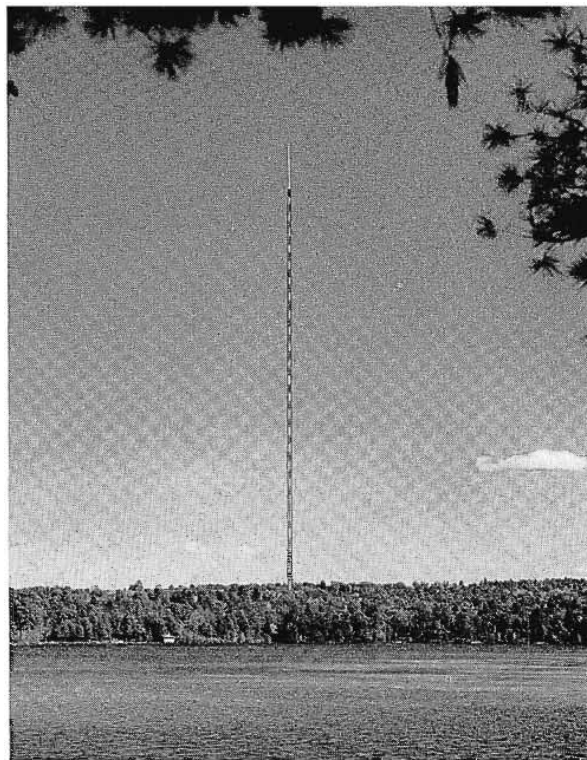

FIG. 1. From a point several miles away the actual height of the world's tallest tower can be seen in relation to the surrounding Maine woodlands.

# WGAN-TV ERECTS THE WORLD'S TALLEST TOWER

*New 1619-Foot Tower With Traveling Wave Antenna  
Extends Station Coverage to 75-Mile Radius*

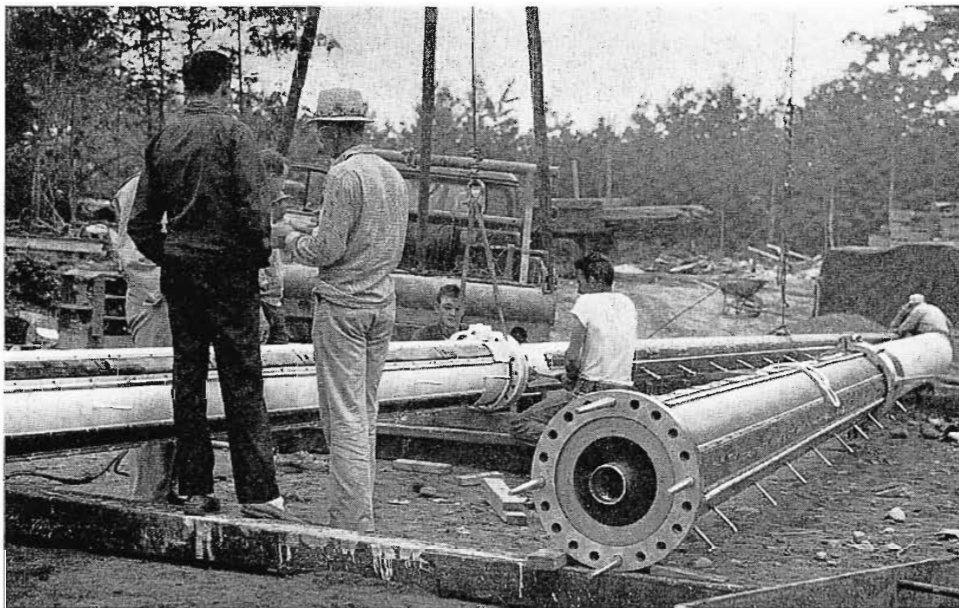

FIG. 2. Sections of the Traveling Wave Antenna were pre-assembled on the ground, before being installed. Note the alignment pins on the flanged end of the antenna section on the right. These pins prevent mis-alignment of the slot arrangement.

One hundred and fifty four feet taller than the Empire State Building, this new tower at WGAN is the highest man made structure in the world. Despite the many construction problems, fewer than five months were spent from ground breaking to final operation. The structure was built on Brown Hill in Raymond, about 25 miles from Portland, Maine. Rodger W. Hodgkins, vice-president in charge of engineering expects to extend coverage of the station to include viewers within a 75-mile radius of the new tower.

### 100-Acre Site

Since this 1619-foot tower is guyed at points 1200-feet from the base, a 100-acre tract of land was required. Intermediate guy anchors are located 650 feet from the base. In order to obtain a tract of land this large WGAN had to locate 25 miles from Portland in one of Maine's resort areas.

### Tower Supports

The concrete base for this tower and the guy anchors required 2,333,680 pounds of concrete to support the 520,000-pound steel tower and the 28,000-pound Traveling Wave Antenna. Four and one-half miles of stranded bridge cable are used to guy the tower at six levels. Guys are tied to the corners of the triangular tower, where greatest support is obtained.

### Three-Man Elevator

Within the triangular tower WGAN has installed a 3-man elevator (with capacity of 500 pounds) which rises to within 40 feet of the tower top. The elevator may be controlled from the cab or from the ground by means of an inductive control system that is impervious to rf interference. Six thousand feet of cable are required to pull this small elevator up to a height of over 1500 feet. Servicing of the antenna and beacons is very easy, since this elevator can be stopped at each of the 10 marker beacon levels for maintenance work.

### Excellent Windloading

Built by Kimco, this tall tower will withstand winds up to 115 mph true velocity or 152 mph indicated velocity. The horizontal deflection, or sway of the structure, in winds at 152 mph is 6-foot, 6-inches. The Traveling Wave Antenna is also designed to withstand a wind velocity of 115 mph.

### Rapid Construction

Less than five months were spent in building this amazing structure. RCA was the prime contractor for the unique installation, and Kline Iron and Steel Company of Columbia, South Carolina, (Kimco) was responsible for design, fabrication, and erection of the tower.



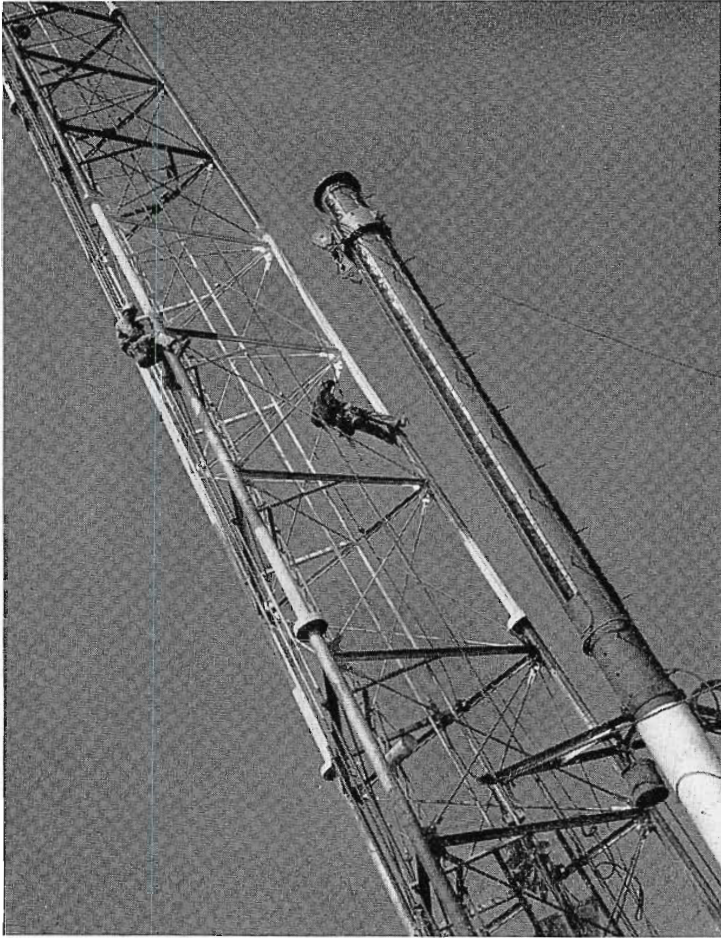

FIG. 3. Here the bottom sections of the Traveling Wave Antenna are being raised into position. The physical size of the tower members is shown in relation to the two men painting the structure.

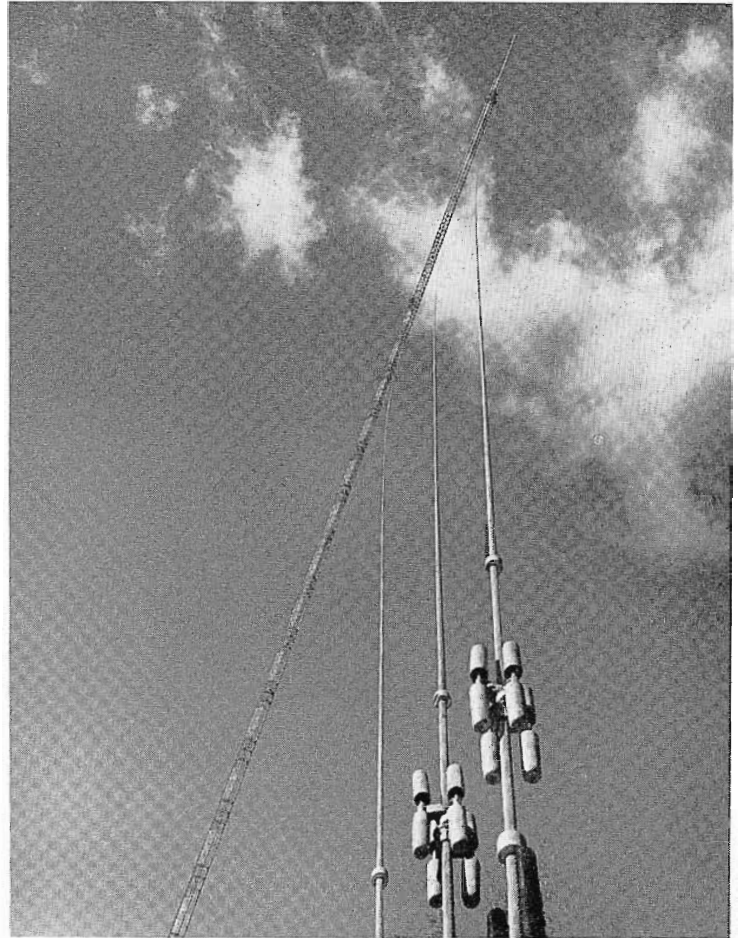

FIG. 4. This shows the WGAN tower looking up from one of the guy anchor points located 1200 feet from the base of the tower.

During the construction, WGAN estimates that 50,000 people visited the site to watch the tower going up.

#### Traveling Wave Antenna

The extreme height of the structure demands an antenna with low wind loading and a simple feed system. The Traveling Wave Antenna meets both requirements. It offers the lowest windloading available. In addition, the TW antenna does not have external feed lines, thus maintenance is reduced. In fact, the TW antenna used at this height will require little attention for years. The 8000-watt lighting system is used to provide proper tower lighting.

#### Worlds' Tallest Structure

WGAN, Kimco, and RCA each have a right to take pride in this 1619-foot tower, which is at present the tallest structure ever erected by man. Most important of all WGAN will always have at its disposal the increased coverage and additional viewing audience that a structure of this height achieves.



FIG. 5. This is the view from the top of this 1619-foot tower at WGAN. When this photo was taken the gin pole was still strapped to the tower (right) for erecting the antenna.



# WBAL, WJZ and WMAR Build the World's First Three Antenna Candelabra

*Cooperation of Three Stations Gives Baltimore  
Better TV Viewing As Stations Combine Their  
Facilities to Cut Costs of Antenna Systems*

FIG. 1. Operation of the worlds' first three-antenna candelabra began in Baltimore on August 9, 1959. The 730-foot tower, shown here, was illuminated with spot lights to let the people of Baltimore know that the new tower had begun operation.

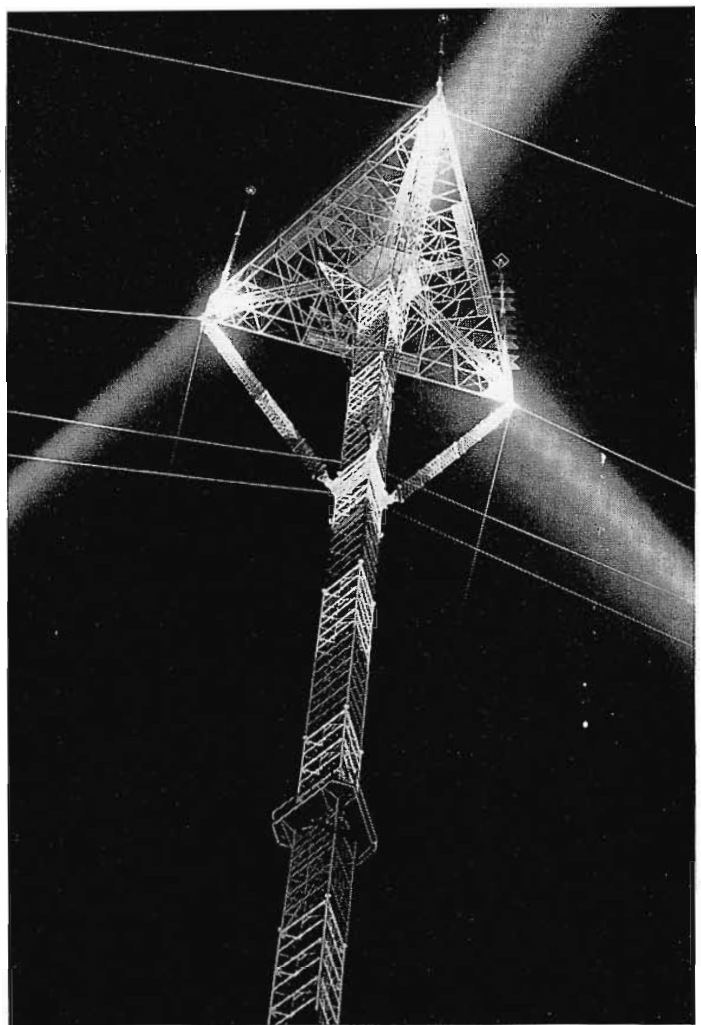

On August 9, 1959, the first three-antenna candelabra tower began operation in Baltimore. WBAL, WJZ, and WMAR are operating at maximum power from this unusual tower to provide TV viewers in Baltimore with improved pictures. Five years of careful planning have produced this amazing structure which could be the pattern for future candelabra arrangements.

## Initial Planning

Shortly after completion of the first candelabra for KRLD and WFAA in Dallas, the stations in Baltimore began to consider this type of arrangement. A separate corporation, called Television Tower, Inc., (TTI), was formed to investigate the possibilities of the candelabra arrangement. Each station became an equal stockholder in TTI, and each has equal control of its operation.

Shortly after hurricane "Hazel" scathed the east coast in 1955, the stations in Baltimore decided that stronger towers must be built. Each station needed a tower that would stand up under hurricane winds, thus any new tower built in Baltimore, it was decided, must meet this requirement. When the candelabra antenna system was finally selected, it was designed to withstand winds greater than any that had been previously recorded in the area.

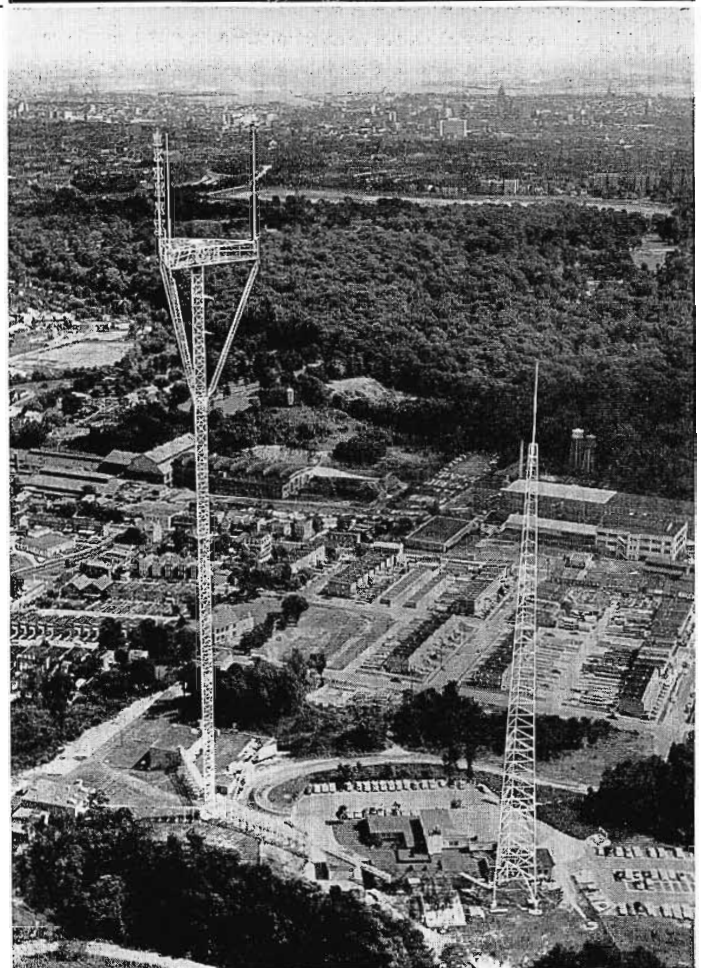

FIG. 2. The Candelabra System overlooks the entire city of Baltimore. Here the new structure is shown in comparison to WJZ's old tower. The suburbs of Washington, D. C. can be seen from the platform on a clear day.



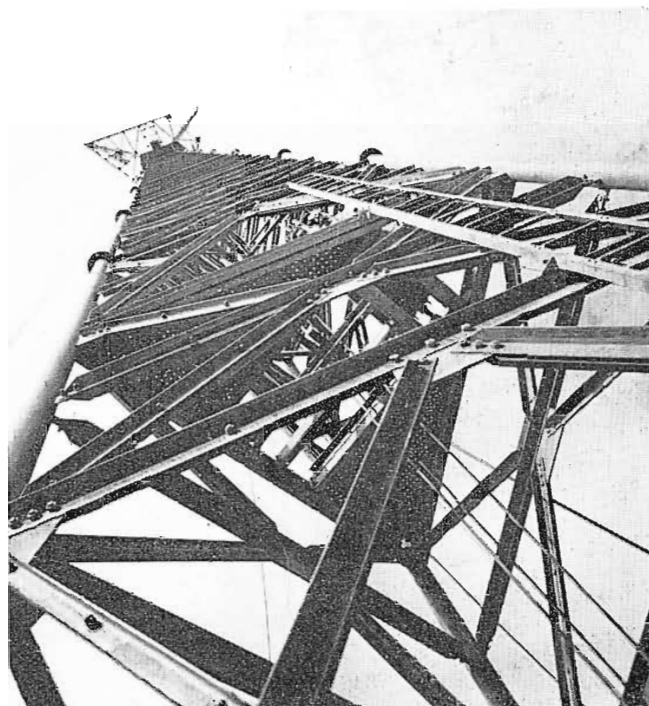
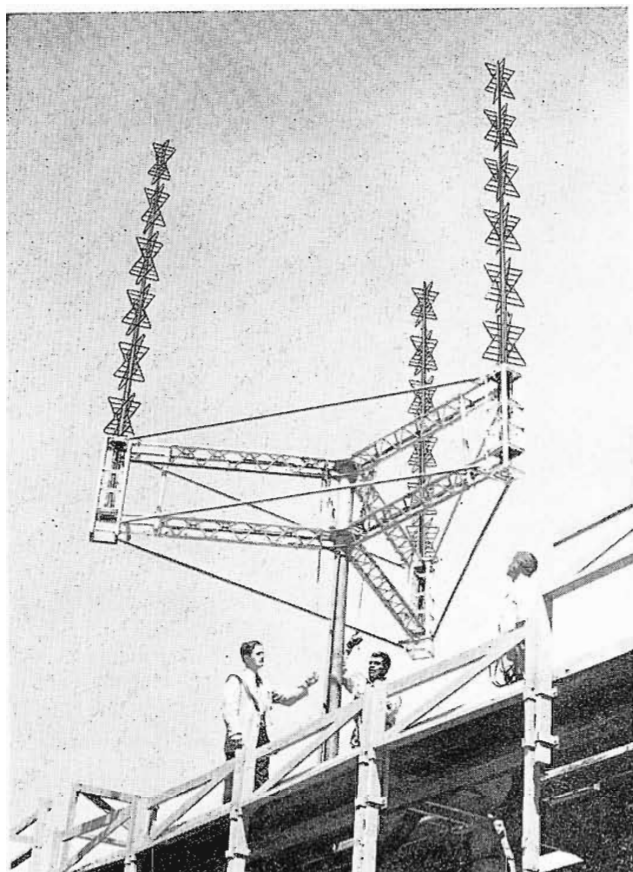

FIG. 4. The solid steel legs of the tower are shown here. Extra strength is obtained from the elaborate cross bracing in the tower. Note that when this photograph was taken the erection was in progress.

FIG. 3. Extensive testing proved the feasibility of this Candelabra system. A scale model, shown here, was constructed by RCA to determine the exact spacing of the antennas and their effects upon each other. The accuracy of this small model has been proved in the performance of the completed structure.

A second problem was height of a new tower. The FCC had set 1000 feet as maximum for the area; however, the Civil Aeronautics Commission would only permit a height of 730 feet. Here TTI compromised and erected a structure 730 feet in height with built in provisions for raising the structure to a full 1000 feet if approval for the additional height were obtained later.

Where to erect it was the next question. WJZ's facilities offered the best point in Baltimore. The site selected for the structure is at an elevation of 300 feet above sea level. This gives the tower a height of 1030 feet above average terrain, yet it still meets CAA requirements. The WJZ site also offered ample room for guy anchor points within the property limits, and enough space for WBAL and WMAR to erect new transmitter buildings.

#### Scale Model Tested

Before building this radically different type of tower, the stations decided to have RCA (the prime contractor) investigate the feasibility of the three-antenna candelabra. Figure 3 shows an exact scale model constructed for this purpose. From this model several important facts were determined: (1) the exact center-to-center spacing of the antennas, (2) the width of the triangular platform, (3) the effects of each

antenna upon the other, and (4) the type of coverage to be obtained. At this time each station was considering the superturnstile type of antenna; however, WBAL and WJZ later decided to use the Traveling Wave Antenna while WMAR selected a custom built superturnstile antenna. The accuracy of scale model testing has been proven by the actual results of the candelabra installation, since all data obtained from the model corresponded with the final structure. Scale

model testing eliminated the chance for errors that could have proved very costly on the completed structure.

#### The Tower Proper

Built by Dresser-Ideco, the tower has three legs which are 12-feet apart at the base and, for the first 480-feet of the structure are solid steel, 7 inches in diameter (see Fig. 4). A special high nickel-chrome alloy steel having very strong corrosion re-

#### Interesting Facts About The 3-Antenna Candelabra System

Total Height (exact).....	729 ft. 2½ in.
Tower Height (exact).....	622 ft.
Platform Height .....	16 ft.
Platform Face .....	105 ft.
Tower Face .....	12 ft.
Center-to-Center Spacing of Antennas.....	101 ft.
Truss Length .....	140 ft.
Guy Levels .....	158 ft., 308 ft., 458 ft., and 602 ft. (Bottom of platform)
Antenna Weights.....	{ WBAL, 18,600 lbs. Type TWA-12A, Ch. 11 WJZ, 18,600 lbs. Type TWA-12A, Ch. 13 WMAR, 25,000 lbs. Type TF-6AL (Special)
Wind Loading.....	{ Tower 70 lbs./sq. ft. Antennas 70 lbs./sq. ft.
Wind Velocity Limit.....	165 mph
Weight of Steel Used.....	500 tons
Amount of Concrete Used.....	2250 tons
Length of Guy Wires Used.....	2.3 miles
Amount of Paint Used.....	3000 lbs.



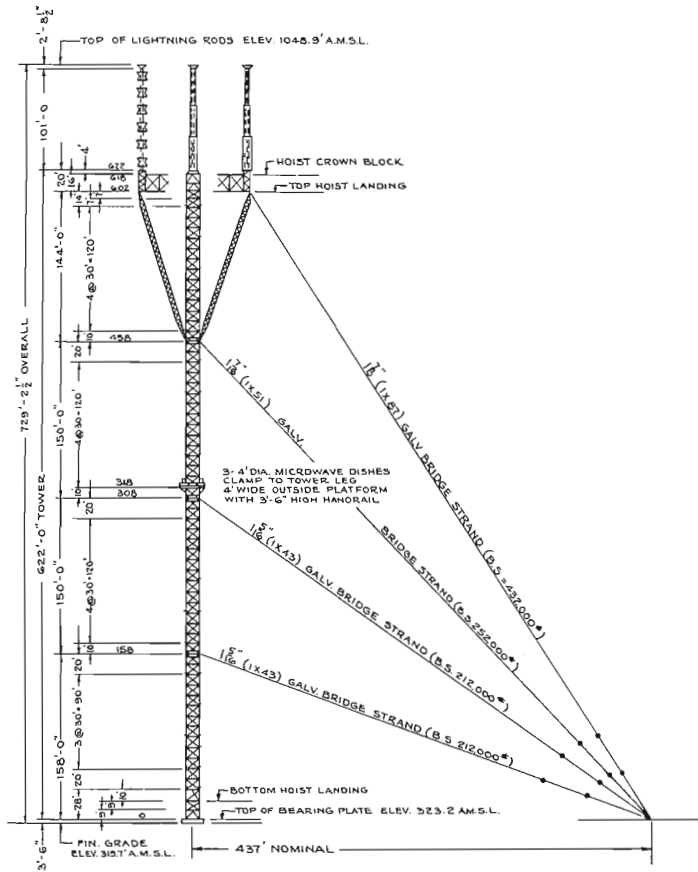

FIG. 5. This shows the four guy levels, their size and material of construction, as well as overall tower dimensions. Note the microwave platform at the 318-foot level. The exact overall height of the structure is 729½-feet.



FIG. 6. One of the guy turnbuckles is shown in comparison to a man. (A dual guy system is used, making it easier to replace guy wires without jeopardizing the entire structure).

sistant characteristics was used in the structure. If ordinary steel had been used, the legs would have to have been almost 12-inches in diameter. Above the 480-foot level the leg diameter reduces to 5¾ inches. Diagonals are made of 1¾ inch solid steel alloy.

Wind loading of the tower is 70 pounds per-square foot, equivalent to peaks of 165 mph winds. Towers used in Baltimore before the Candelabra were only 80 mph structures, thus hurricane dangers have been greatly minimized.

#### Dual Guys

Twelve sets of dual galvanized guy wires support the structure at four levels (see Fig. 5). Size of the guy wires range from 1 5/16 to 1 7/8-inch stranded bridge-type steel cable. Breaking strengths, from 212,000 to 432,000 pounds offer ample protection. The dual guys afford extra reliability and make it easier to replace them without jeopardizing the structure. Figure 6 reveals the extraordinary size of the guy turnbuckles. A total of 14,700 feet (2.8 miles) of bridge cable was used in the guy wires. Two "Stockbridge" harmonic guy dampers are used in each guy wire to eliminate harmonic vibration.

#### Tower Base

A 20-foot deep, hexagon-shaped reinforced-concrete pier supports the weight of the tower (see Fig. 7). This base is 15 feet on each face, and it withstands a complex thrust of 3,800,000 pounds, a bending minimum of 5,300,000 foot-pounds and a horizontal shear of 68,000,000 pounds. The tower base, as well as the entire structure

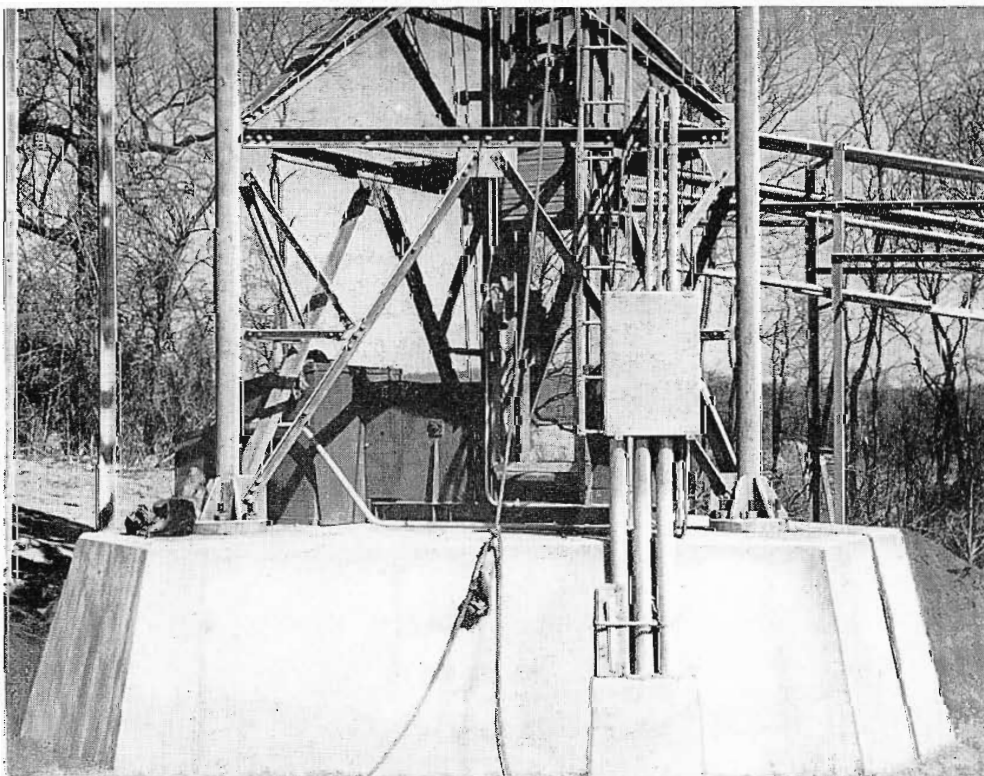

FIG. 7. This is the tower base which measures 15 feet on each face. The reinforced concrete used in this base was poured to a depth of 20 feet to compensate for conditions caused by a nearby quarry.



was designed to withstand earthquake conditions, because of blasting at a nearby quarry. A total of 2250 tons of concrete were used for the base and the three anchor points. It took a line of concrete trucks spaced six minutes apart from 5 a.m. to 8 p.m. to fill just one of these four excavations with concrete.

**Guy Anchors**

Each of the three anchors is in the form of a concrete polygon buried flush with the ground (see Fig. 8). The 16-foot deep concrete anchors are 33 feet on a side. The anchor points are of molded concrete, and extra points were poured anticipating a future increase in tower height. The anchors were designed for an upward thrust of 3,320,000 pounds and a horizontal shear of 1,734,000 pounds.

**The Platform**

The Candelabra platform was built 625 feet above ground. Triangular in shape, the platform is 105 feet on a face and is 16 feet high, supporting over 60,000 pounds of antennas including auxiliaries and microwave equipment (see Figs. 9 and 10). Knee

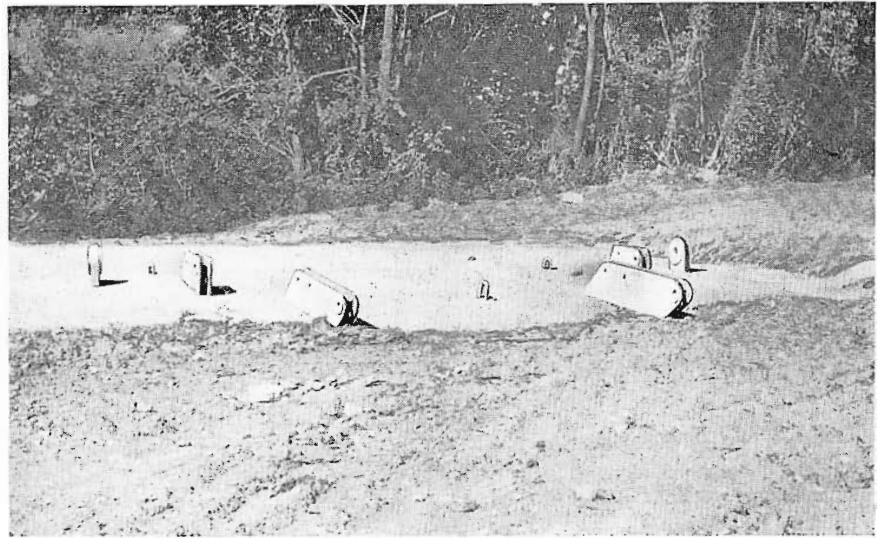

FIG. 8. Three guy-anchor points, each identical to the one shown here, are used to support this tower. Extra anchor points were installed for future elevation of the structure. The anchors are 16 feet deep and 33 feet on a side, made of reinforced concrete.

FIG. 9. The platform, shown from the air, begins at the 625-foot level. The two Traveling Wave and one Superturnstile antennas are mounted on the corners of the platform. In the center is the penthouse, connecting with each antenna by catwalks. One of the microwave dishes and a standby two-bay superturnstile antenna can also be seen.

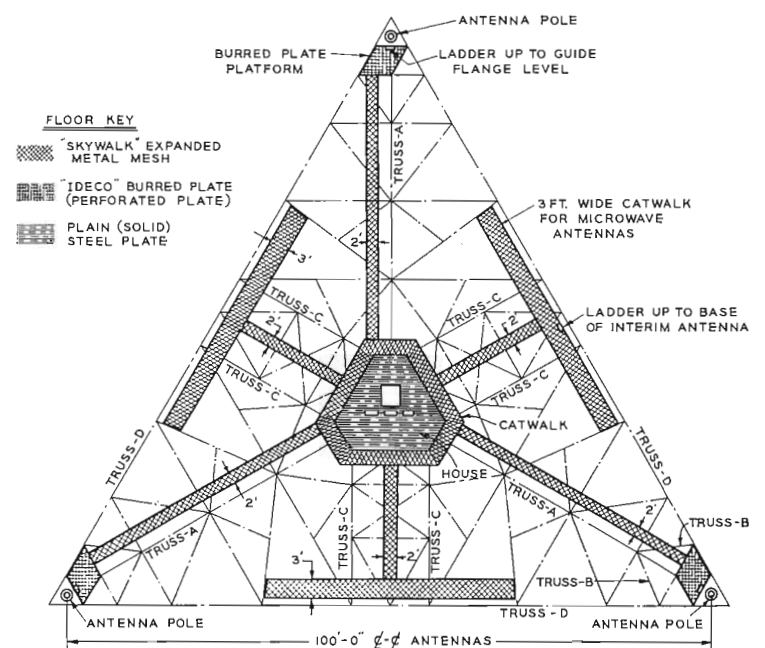
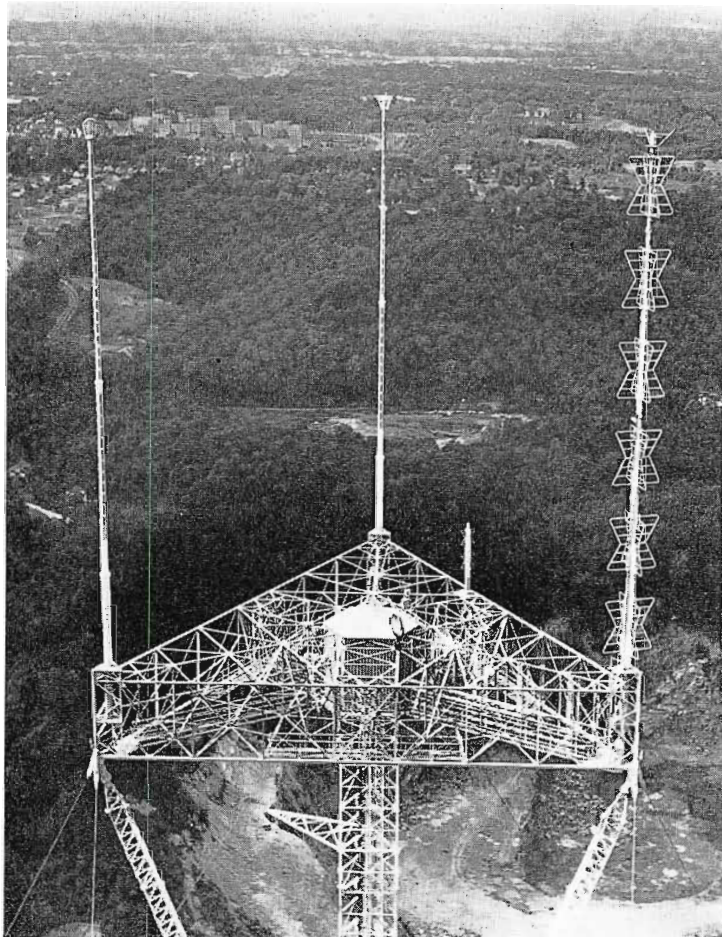

FIG. 10. This is a drawing of the platform showing location of catwalks, penthouse, and antennas. The platform measures 105 feet, end to end, on a face.



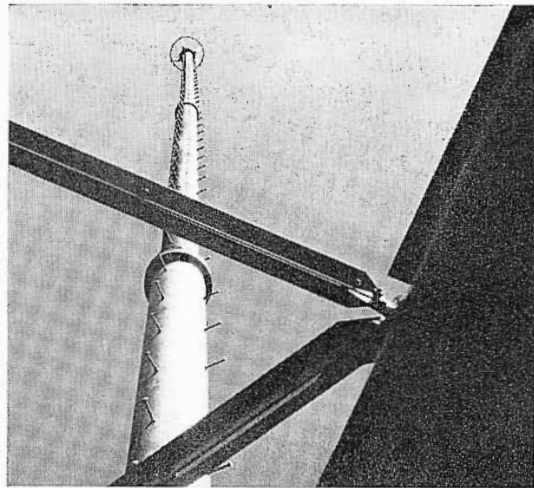

FIG. 11. This is one of the Traveling Wave Antennas as seen looking up from the platform catwalk.

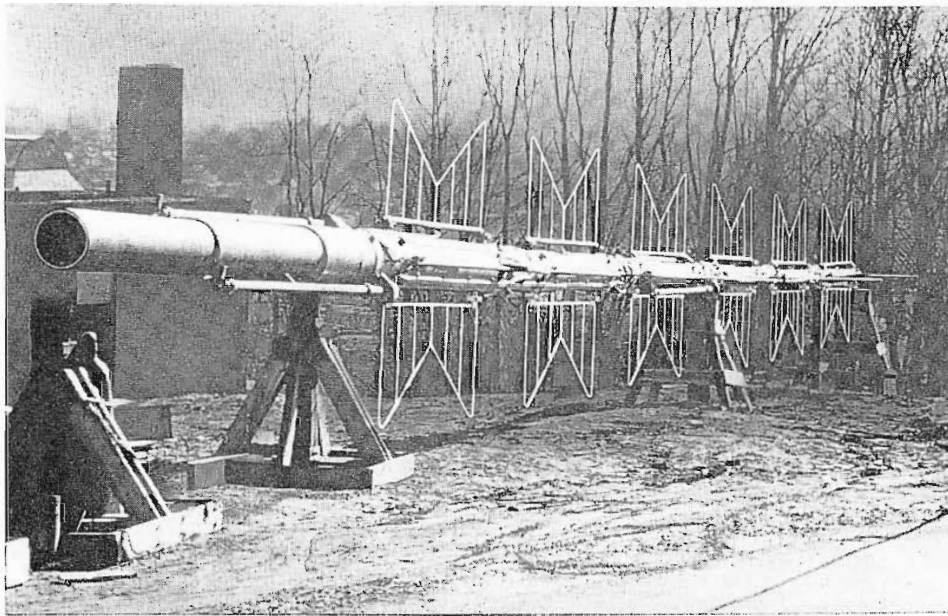

FIG. 12. WMAR's custom built Superturnstile antenna is shown on the ground just after final assembly.



FIG. 13. The transmission line of each station is run to the tower on a steel frame as shown here at the WBAL building. Small pipes have been mounted over the lines to prevent damage from falling ice.

braces support the platform at a point 140 foot from the top of the tower (see Fig. 2). Steel catwalks on the lower level of the platform permit maintenance on the antennas and microwave gear. At the platform level a person has a view for 33 miles, almost to Washington, D. C., on a clear day.

#### Antennas

Each corner of the triangular platform supports one antenna. WBAL and WJZ are using Traveling Wave Antennas while WMAR is using a custom built special TF-6AL Superturnstile antenna (see Figs. 11 and 12). An emergency antenna for WBAL is mounted on the center of the platform face, consisting of two bays of a Superturnstile (see Fig. 9). WJZ plans to hang a separate aural antenna from the bottom of the platform, and to use the Traveling Wave Antenna for visual only. In an emergency WJZ will be able to use either antenna for both aural and visual signals. The special WMAR Superturnstile has split feed provisions so that either the upper or lower six sections can be used separately.

Preliminary tests made on these antennas indicate that all predicted performance data will be met. The emergency antenna arrangements offer the stations added reliability, and permit operation at reduced power in case of damage or for normal maintenance.

#### Transmission Lines

WMAR is using two  $6\frac{1}{8}$ -inch line for the main feeds. WBAL and WJZ have installed  $3\frac{7}{8}$ -inch auxiliary lines and  $6\frac{1}{8}$ -inch main lines. WBAL's lines run approximately 825 feet, WJZ runs 897 feet and WMAR is the shortest with a 746 foot run. Transmission lines are run to the tower base on steel supporting braces (see Fig. 14). Above the transmission lines the stations have placed a row of small pipes to protect the transmission lines from falling ice.

#### Tower Elevator

A two-man radio-controlled elevator has been installed within the tower for maintenance (in an emergency it could carry four men). The elevator takes personnel to the floor level inside the penthouse at the top of the tower. Two-way communication is possible at all times from elevator to ground. The elevator can be controlled from the ground or the penthouse on the platform, as well as from within the elevator itself.

#### Microwave Facilities

A 3-foot catwalk built around the tower at the 300-foot level is used for microwave antennas. The stations will use microwave at this level primarily for studio-transmitter links. WBAL, WJZ and WMAR



have their remote microwave gear mounted on the upper portion of the platform. These three antennas have been placed close to the roof of the penthouse on the platform. WJZ does not require a STL link since its studios are at the tower site.

### Station Facilities

The Baltimore Candelabra tower was built on land recently purchased from WJZ, and this required WBAL and WMAR to move their transmitter plants to the new site. The new buildings erected by WBAL and WMAR are adjacent to the antenna base. WJZ has both studio and transmitter facilities at the site, eliminating microwave links. Figure 15 shows the tower and guy locations in relation to the various buildings; transmission line runs are also indicated.

### Costs Equal For Each

With each station absorbing one third of the total cost of this Candelabra tower the cost per station obviously became lower. Now that this candelabra is operating the maintenance costs should be lower for each

station. This type of antenna arrangement also benefits the TV viewer, by making it simpler to orient antennas. Baltimore's new Candelabra system is the only one of its type in the world, and it is a tribute to the stations cooperation.

### Those Who Participated In This Candelabra System

- |  |   |
|--|---|
| <ol style="list-style-type: none"> <li>1. The Engineering Committee of Television Tower, Inc.;<br/>WBAL-TV, John Wilner (Chairman)<br/>WJZ-TV, Ben Wolfe<br/>WMAR-TV, Carl Nopper</li> <li>2. Television Tower, Inc. Board of Directors:<br/>WBAL-TV, Mr. Provost and Mr. Guntz<br/>WJZ-TV, Mr. McClay and Mr. Wolfe<br/>WMAR-TV, Mr. Jett and Mr. Schmick of the Sunpapers</li> <li>3. Prime Contractor:<br/>Radio Corporation of America<br/>Broadcast and Television Equipment Division</li> <li>4. Tower Design and Fabrication:<br/>Dresser-Ideco, Inc.<br/>Columbus, Ohio</li> <li>5. Foundation Contractor:<br/>Whiting-Turner Contracting Co.<br/>Baltimore</li> </ol> | <ol style="list-style-type: none"> <li>6. Tower Erector:<br/>J. F. Beasley Construction Co.<br/>Oklahoma City</li> <li>7. Antennas and Transmission Lines:<br/>Radio Corporation of America<br/>Broadcast and Television Equipment Division</li> <li>8. Mechanical Consultant:<br/>Dr. Robert Rowe<br/>Duke University</li> <li>9. Roadway Grading:<br/>Drummond and Co.<br/>Baltimore</li> <li>10. Underground Power:<br/>Baltimore Gas and Electric Co.</li> <li>11. Underground Television Telephone Facilities:<br/>Chesapeake and Potomac Telephone Co.</li> </ol> |
|--|---|

FIG. 14. Transmitter building locations are shown in relation to the tower. The guys are shown with the longest running south, down hill.

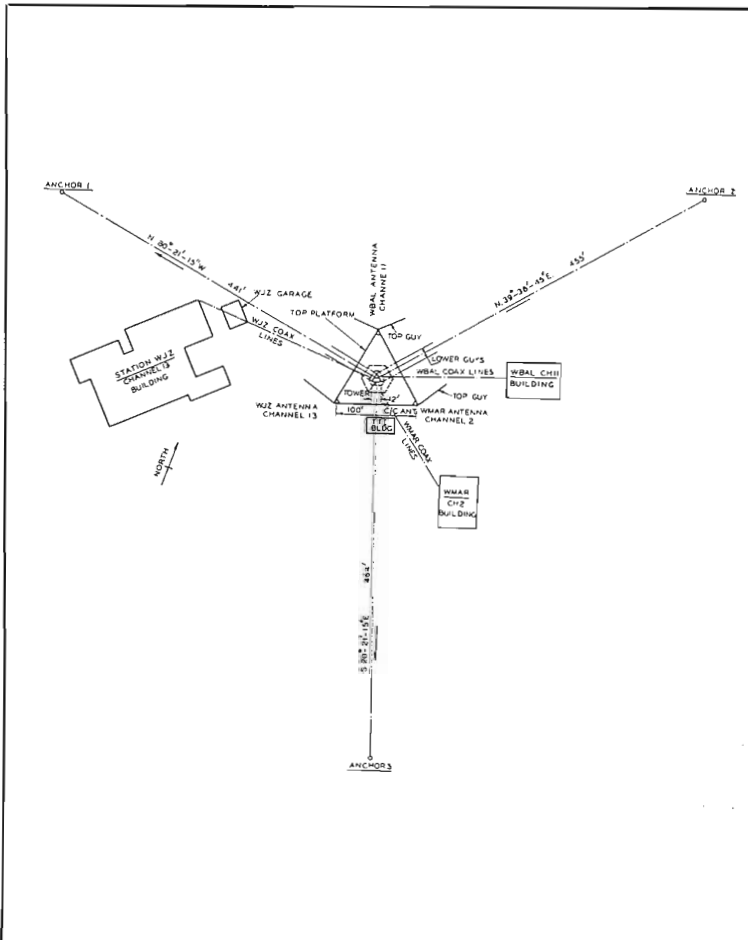
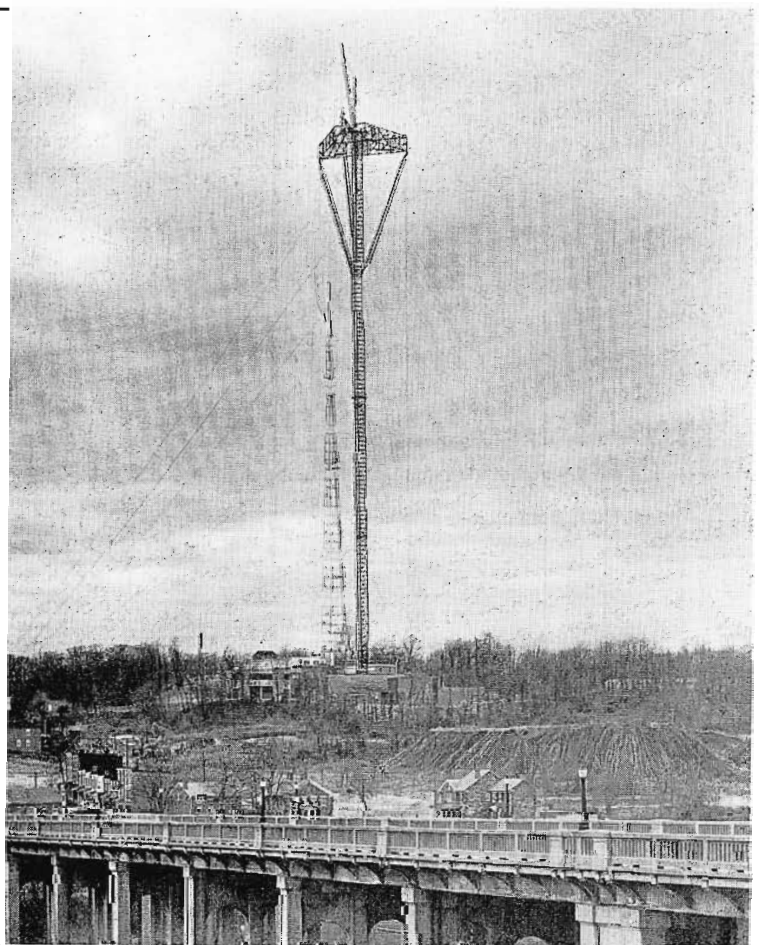

FIG. 15. The Candelabra is shown in contrast to the surrounding terrain. The overall height of the structure is approximately 1000 feet above sea level; however, the physical height of the structure is 730 feet.





# NEW "B" SERIES TRAVELING WAVE ANTENNA

*Simplified Construction Combined With Higher Aperture Efficiency Produces a Low Cost Installation for High-Band, High-Gain Operation*

by MATTI S. SIUKOLA, *Broadcast and Television Engineering*

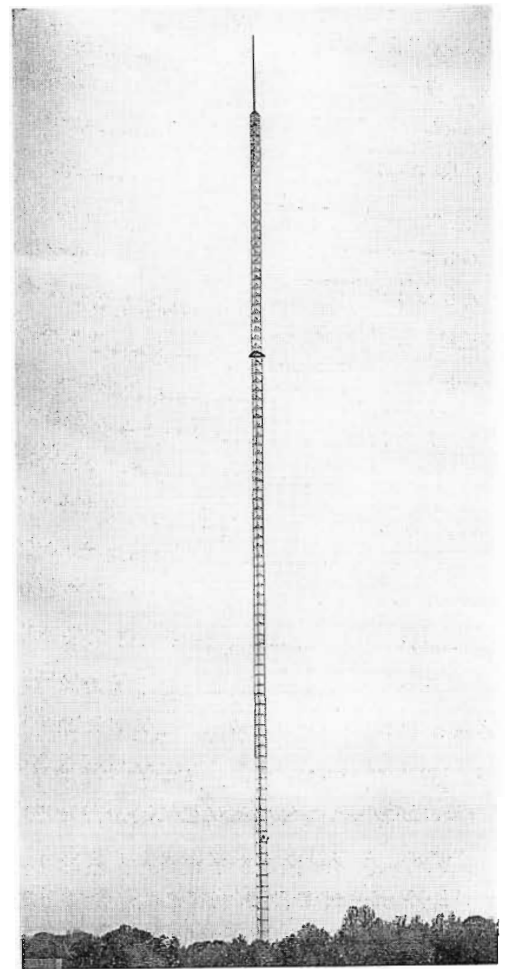

FIG. 1. Traveling Wave Antennas are now in operation at many stations. This shows the installation at WLW-A, Atlanta.

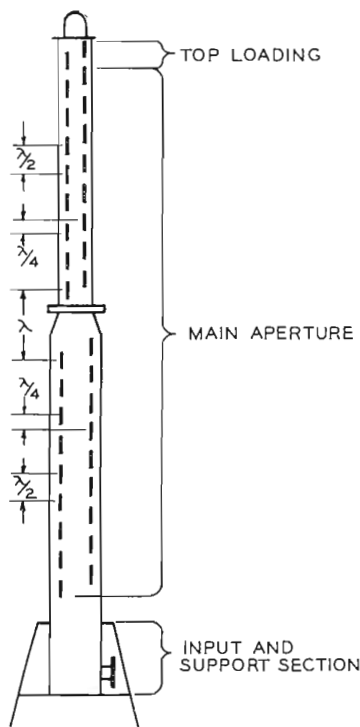

FIG. 2. Outline drawing of the A-series Traveling Wave Antenna shows the slot spacing in the main aperture.

Television industry acceptance of the Traveling Wave Antenna, introduced in 1957<sup>1</sup>, has been very gratifying, and the principle has proved itself in service.

There are many reasons for this: properly shaped vertical pattern, excellent circularity, low VSWR, high power handling capacity, and low wind load. The new "B"-series not only retains these characteristics, but also incorporates changes in design which make it more economical.

To aid broadcasters in making the better choice the differences between the standard A-series TWA and the new B-series will be explained and performance compared.

<sup>1</sup> M. S. Siukola and G. A. Kumpf, "Traveling Wave Antenna," *Broadcast News*, Vol. No. 94, April, 1957.

M. S. Siukola, "The Traveling-Wave VHF Television Transmitting Antenna," *IRE Transactions on Broadcast and Television Receivers*, Vol. BTR-3, October, 1957.

G. E. Erwin, "Traveling Wave Antenna Proves Itself in Service," *Broadcast News*, Vol. No. 103, March, 1959.

H. E. Gihring, "Latest Trends in TV Broadcast Antennas," *Broadcast News*, Vol. No. 105, September, 1959.

## TW Principles of Operation

As described in the previous articles the energy is fed into the Traveling Wave Antenna through a broadband tee at the bottom. In the antenna the signal travels upwards in the large coaxial transmission line formed by the steel shell of the antenna as the outer, and a copper tube as the inner conductor (see Fig. 2, 3 and 4). At each pair of slots two capacity probes extract, and the slot pair radiates, a portion of the power from the line. Thus the signal level in the line is reduced exponentially. The small fraction of total input power reaching the top end of the antenna is radiated by the two slot-pair top loading.

The resulting exponential distribution of illumination in the Traveling Wave Antennas produces a smooth null-free vertical radiation pattern with utmost simplicity of radiating elements and feed system (see Fig. 9, and 13 through 16). The traveling wave nature of the feed in the antenna assures low input VSWR (see Fig. 6). Excellent horizontal pattern circularity is derived from the unique combination of supporting structure and radiators, which, undisturbed by an external feed system, forms the pattern on the turnstile principle from



two single slot pair patterns (see Fig. 3 and 5). The compensation provided by the proper design of the slot radiators maintains constant wavelength instead of constant velocity in the transmission line for frequencies in the channel thus assuring proper pattern bandwidth.<sup>2</sup> Rugged and simple mechanical construction offers ease of assembly and troublefree operation. The cylindrical shape is ideal for low wind load.

### Fewer Slots, Same Performance

The development of the B-series Traveling Wave Antenna involved several changes from the A-series. From the electrical point of view there are few major differences. The number of slots has been reduced to approximately half of the original number.

In the A-series the slot pairs are spaced about a quarter wavelength apart and located alternately in two perpendicular vertical planes as shown in Figure 3. Thus, as far as the vertical radiation pattern is concerned there is a radiator at approximately every half wavelength along the principle planes. Since an exponential amplitude distribution of illumination is combined with a linear, in most applications, zero phase distribution is obtained to produce the well known null-free pattern. However, it can be shown that if every other slot in a row is left out, but the exponential rate of illumination per wavelength is maintained; the gain of the antenna will remain essentially constant when a large number of radiators is used. Also, as demonstrated by the curves in Fig. 7, down to about twenty degrees only minor variations result in the vertical pattern. Below this angle the service area is normally less than half a mile from the station site, and too close to be considered from the pattern point of view. Thus, the differences are largely academic, and for all practical purposes an antenna with one wavelength spacings gives the same service as one with half wavelength spacings.

Hence, with respect to gain and pattern, the Traveling Wave Antenna can be simplified by eliminating every other slot pair in each plane. It should be noted, however, that the remaining pairs will not be equally spaced along the coaxial transmission line, but every other spacing will be approximately a quarter wavelength and the remaining spacings approximately three quarters of a wavelength long as shown in Fig. 8. This configuration will retain the traveling-wave type of feed, and maintain the inherently excellent impedance and pattern

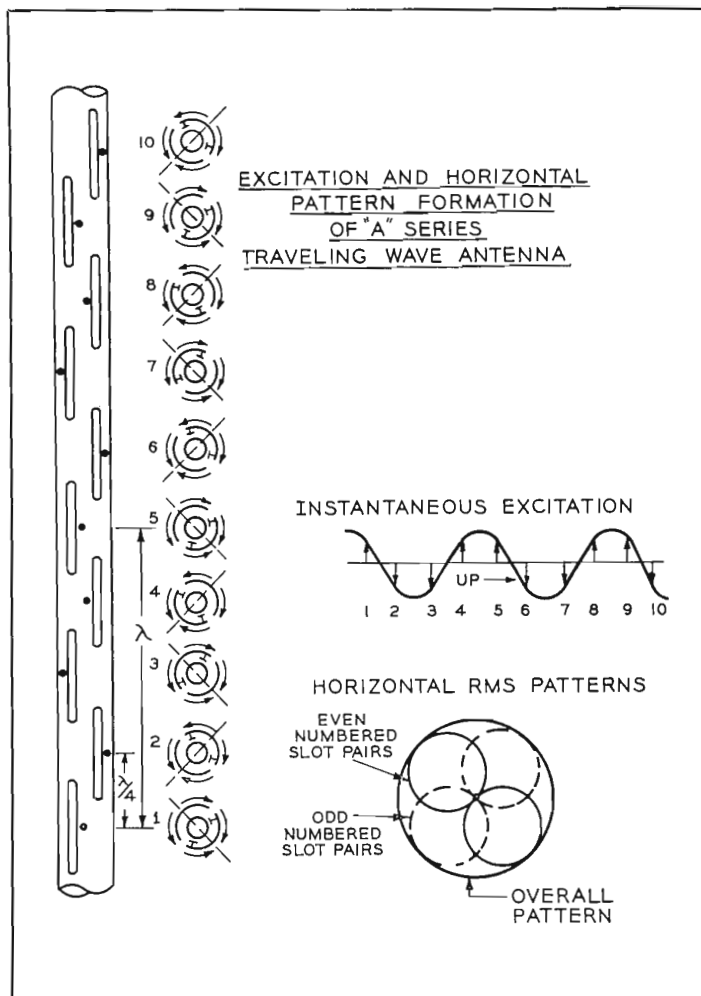

FIG. 3. This drawing shows a portion of the main aperture of the A-series Traveling Wave Antenna. Slot pairs are spaced a quarter wavelength apart alternately in two perpendicular vertical planes. Orientation of coupling capacitors gives the slot pairs an effect which is similar to that of a dipole antenna. Alternative location of capacitors produces proper phasing for the slots in each plane. In cross-sectional views current directions are indicated at an instant, and curve shows instantaneous excitation magnitudes. Horizontal pattern formation on turnstile principle is also illustrated in the form of two figure-eight patterns.

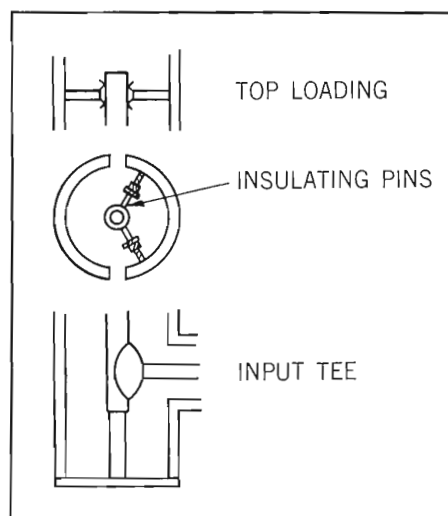

FIG. 4. This shows the method of supporting the inner conductor in an A-series antenna. The input tee with shorting plate support, and top loading short with indication of the thermal expansion joint are also shown.

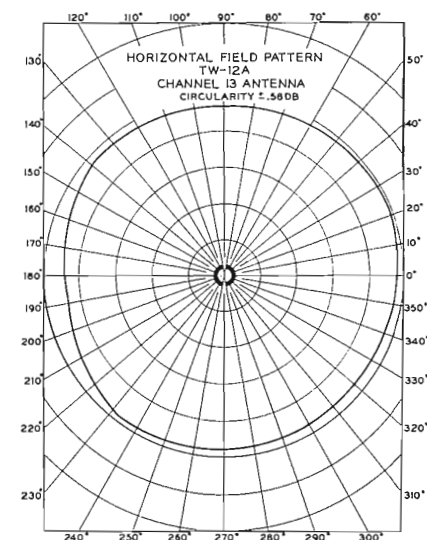

FIG. 5. The measured horizontal field pattern of a TW-12A (gain of 12) Channel 13, shown here, is for a typical A-series antenna.

<sup>2</sup> M. S. Siukola, "Traveling Wave Television Broadcast Antenna." *AIEE Conference Paper* No. 59-459, Winter General Meeting, New York, February, 1959.



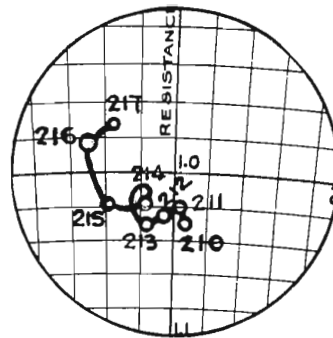
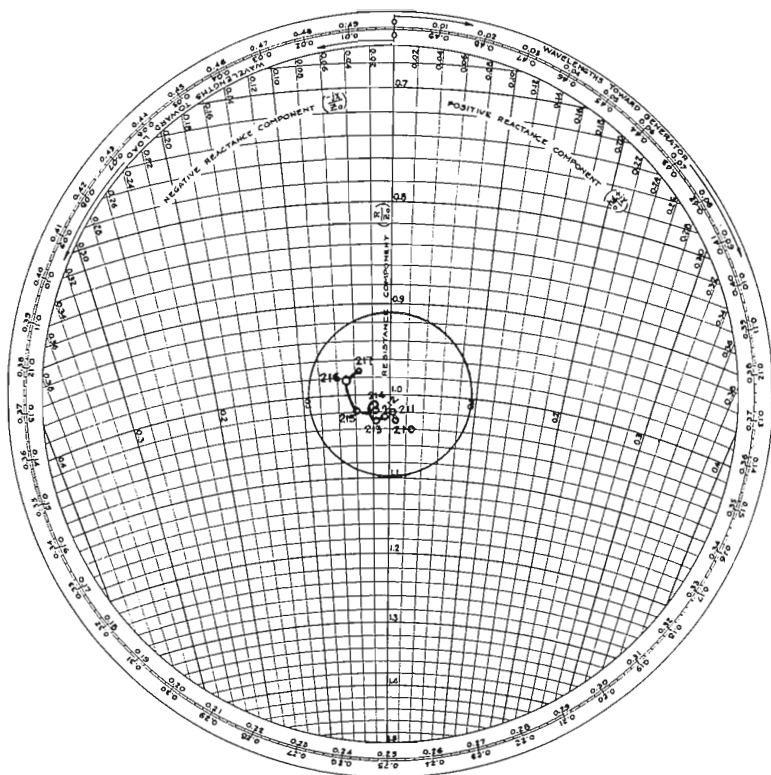

FIG. 6. Measured input impedance of a TW-18A (gain of 18) Channel 13, built for WGAN, in Portland, Maine. The actual plot of the input impedance has been blown up to make it easier to read.

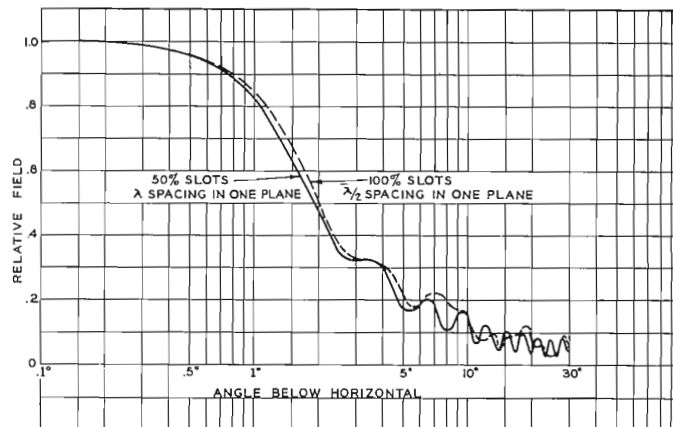

FIG. 7. These curves show the negligible effect on the vertical field pattern of a gain of 15 Traveling Wave antenna produced by eliminating half the slots in each plane.

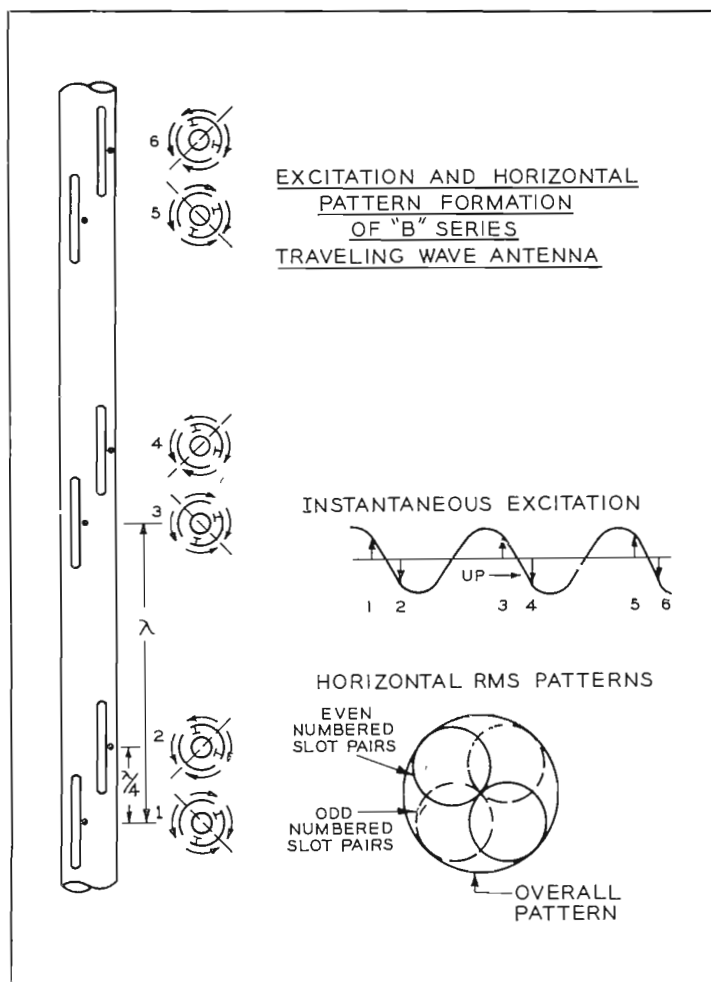

FIG. 8. This is the main aperture arrangement for a B-series Traveling Wave Antenna. Note the differences between the A-series as shown in Fig. 3, the resulting pattern is the same.

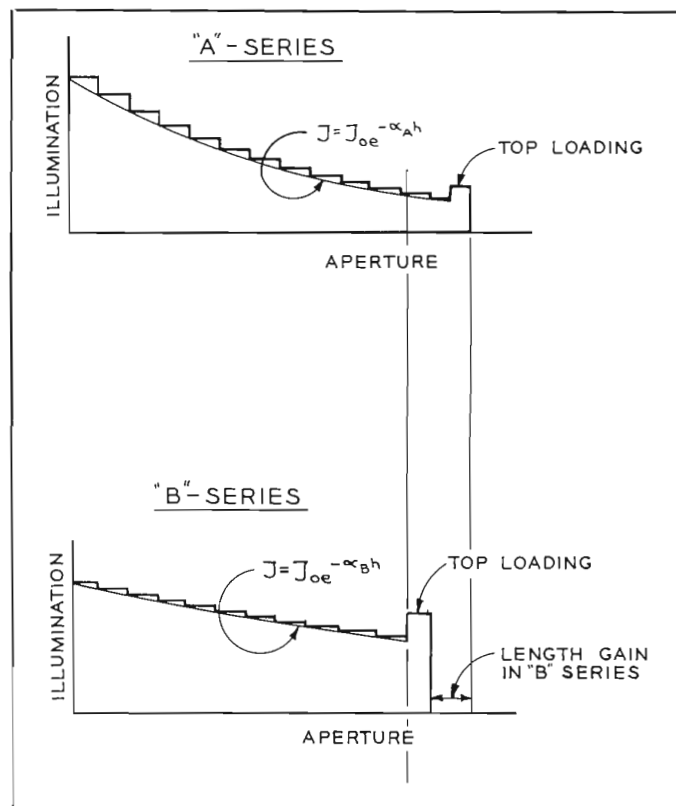

FIG. 9. Note the differences in the distribution of the illumination of "A" and "B" Series Antenna for the same gain. The illumination of the B-series is more uniform because of the lower attenuation rate and the higher top loading energy. Shorter overall length of B-series as a result of the higher aperture efficiency, is also illustrated.



characteristics typical to Traveling Wave Antennas.

As indicated before, the best video response or pattern bandwidth in the Traveling Wave Antennas is obtained by proper velocity compensation within the coaxial transmission line. In the A-series each slot pair compensates for the variation within the quarter-wave spacing between the slot pairs. When the number of slot pairs in the aperture is reduced to half, the compensation demand per slot pair is doubled to maintain optimum response. Since the same attenuation rate per wavelength is used, the attenuation per slot pair will be doubled. This being approximately linearly related to the compensation, the required radiator characteristics remain unchanged for the optimum compensation. Thus, essentially the same performance in every respect can be provided by a Traveling Wave Antenna having only 50 percent of the slots.

### Increased Aperture Efficiency

Another modification employed has been the increased aperture efficiency factor or gain per wavelength of aperture. In the A-series the attenuation of the signal from the input to the top end of the antenna is high enough so that the energy radiated by the top loading is only a few percent of the input power.

This type of exponential illumination (see Fig. 9), which has a very low value at the far end, produces a very smooth null-free vertical pattern (see Fig. 13 through 16). However, the high energy level below the main lobe, although very often desirable, results in low aperture efficiency. Thus for a specified gain the A-series is relatively long. Typical figures for the gain per wavelength are from 0.77 to 0.8 as compared to 0.9 to 1.0 for antennas with less fill.

This close-in coverage provided by the A-series is actually better than required in other than large metropolitan centers or in areas where the population is near the antenna but at a much lower altitude, such as on a mountain side. Therefore, a portion of it can be traded for some more desirable feature of the antenna.

In the B-series an increase in aperture efficiency has been secured by very simple means with only a slight sacrifice in field strength. As is well known, the more uniform the illumination is along the aperture of an antenna, the higher gain per wavelength obtained. The illumination of Traveling Wave Antennas can be made more uniform by reducing the attenuation through

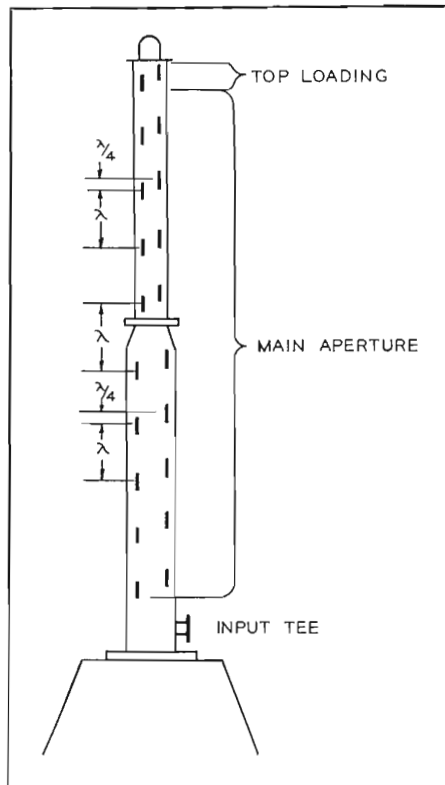

FIG. 10. This is an outline drawing of a B-series antenna with every other slot pair eliminated. This can be compared to the A-series as shown in Fig. 2.

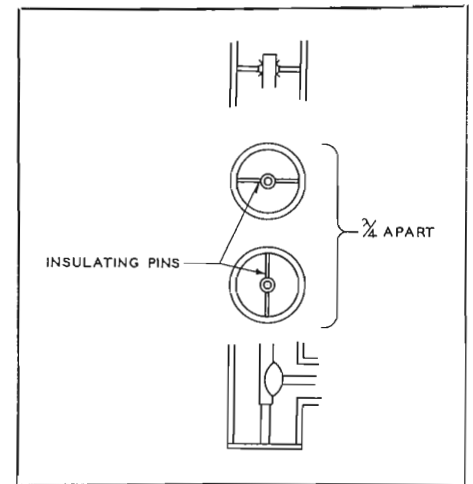

FIG. 11. In the B-series the inner conductor weight is supported by the base plate, which doubles as electrical short. The centering of the inner conductor is accomplished by groups of two pairs of insulating pins. The pairs of pins are displaced by a quarter wavelength to cancel reflections in the transmission line. (Compare to Fig. 4 which shows the A-series).

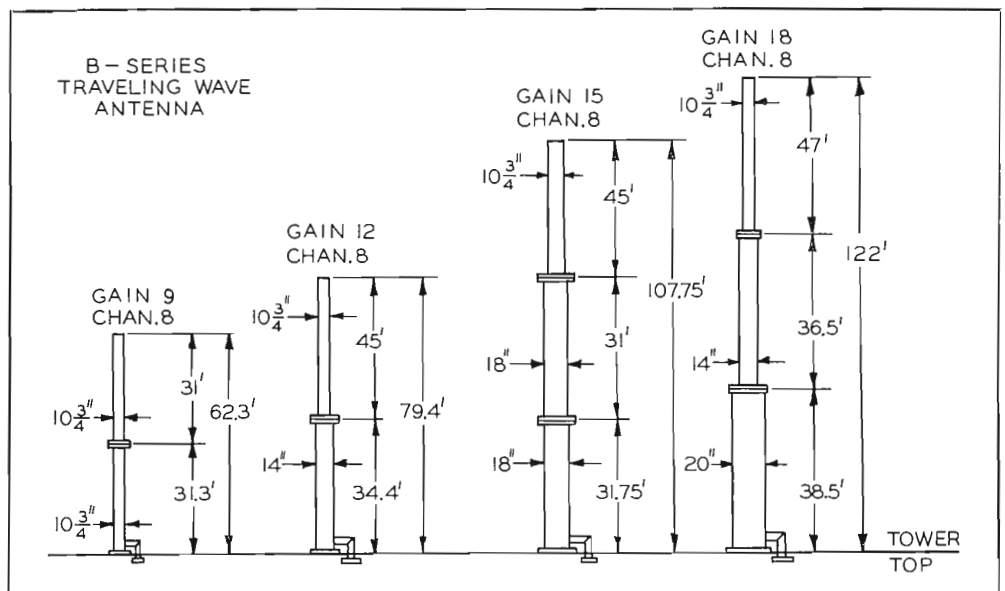

FIG. 12. Major dimensions of the B-series antennas are shown here.

the antenna. This increases gain of the main aperture. Simultaneously, however, the energy remaining at the top end increases. Since it is radiated by the low-gain top loading, this reduces the overall gain. The optimum attenuation with respect to gain is obtained when the increase of gain by more uniform main aperture illumination is equaled by the reduction of gain due to power fed through to the top loading; thus

being used inefficiently. However, before the optimum gain per wavelength is reached, the video response of the antenna starts deteriorating from its optimum value.

To achieve the optimum video response a proper amount of velocity compensation is required for any specified gain, percentage bandwidth, and attenuation rate per wavelength. The actual compensation, however, is limited both theoretically and by



FIG. 13. to 20. Typical Traveling Wave vertical field patterns for the four nominal values of gain obtained in both A and B-series antennas are shown here for comparison.

"A" Series

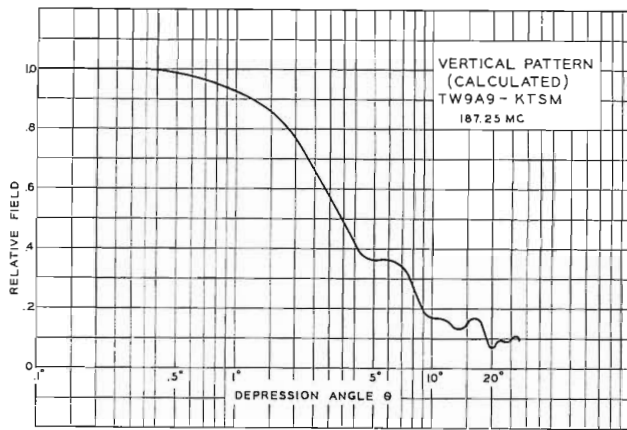

FIG. 13.

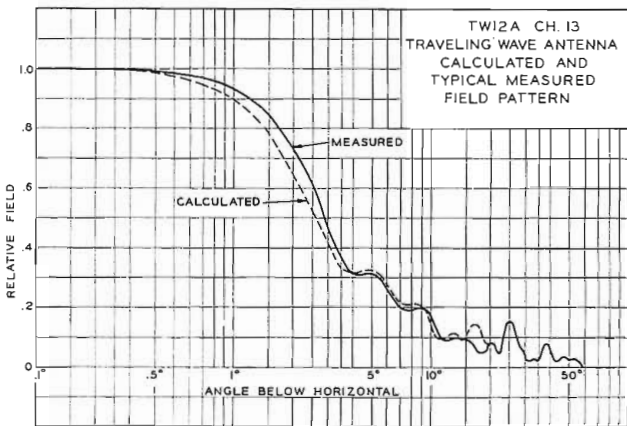

FIG. 14.

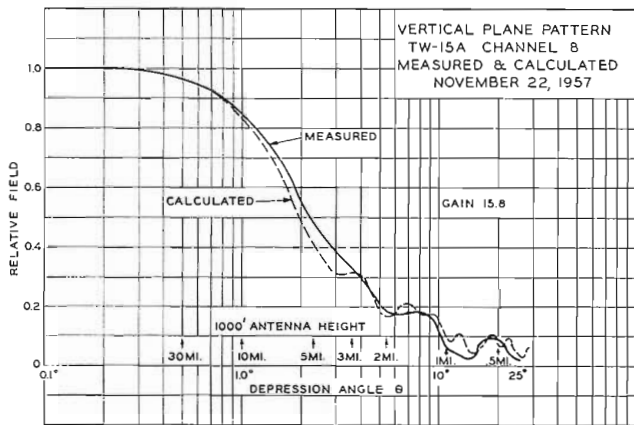

FIG. 15.

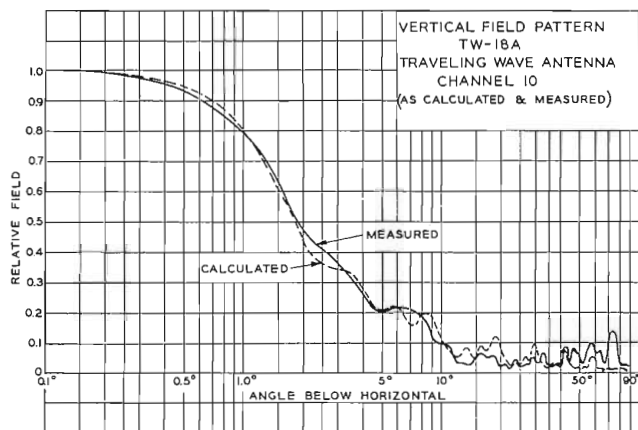

FIG. 16.

"B" Series

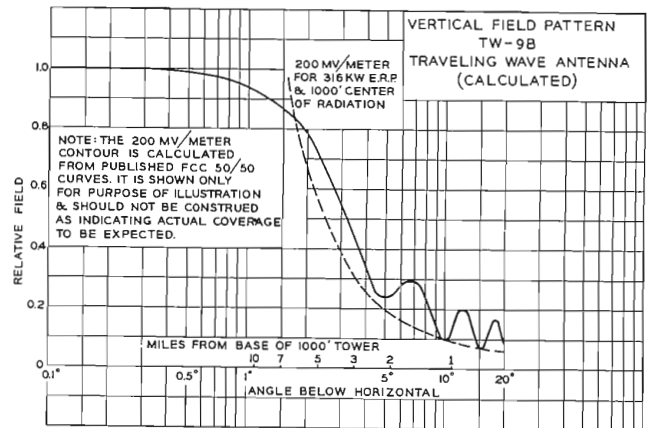

FIG. 17.

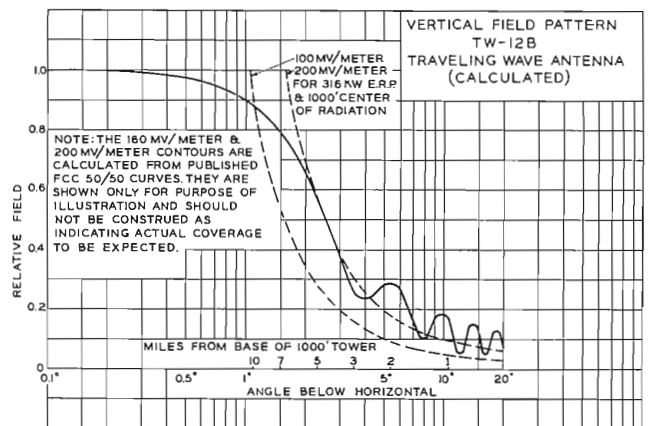

FIG. 18.

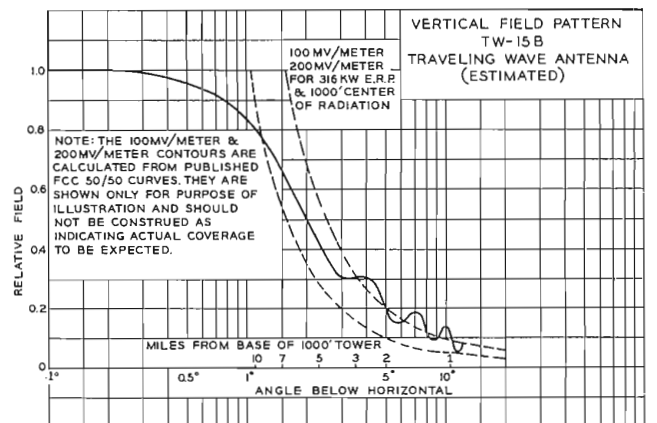

FIG. 19.

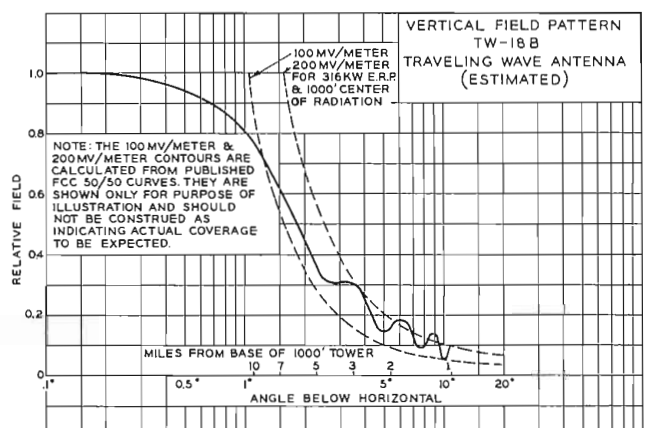

FIG. 20.



the availability of proper radiator characteristics. Therefore, in reaching higher aperture efficiency by reducing the total attenuation through the antenna, the maximum usable aperture efficiency is actually limited by the necessity to maintain the optimum video response. On lower gain B-series Traveling Wave Antennas, gains-per-wavelength as high as 0.87 to 0.9 can be achieved. Figure 9 illustrates the differences in illumination of the two series of the Traveling Wave Antennas for the same gain.

A natural result of the more uniform illumination and higher power being radiated by the top loading is that nulls start to appear in the vertical pattern (see Figs. 17 through 20). In most locations, however, even these energy levels produce a very adequate signal strength, and thus appreciable savings in the cost of the antenna installation can be realized for a specified gain with no appreciable sacrifice in performance.

### Simplified Mechanical Construction

For maximum rigidity and stability the A-series employ teflon inserts in the coupling capacitors to support the inner conductor radially (see Fig. 4). In B-series separate supporting pins are provided to simplify mechanical construction, and to facilitate adjustment. This design affords ample support and decrease costs of construction. These supporting pins are used in groups of two pairs, the pairs being axially displaced by a quarter wavelength to avoid any adverse effect on the inherently excellent impedance characteristics of the Traveling Wave Antenna (see Fig. 11).

The A-series are provided with buried section for tower mounting. The B-series is designed for pedestal mounting with a flange at the bottom (see Fig. 10). This provides sufficient mechanical strength but cuts cost of installation, since the slight additional cost of tower for equal overall rigidity will be more than offset by the antenna savings.

Except for these two differences, the B-series uses the same proven methods and materials as the A-series, giving the same high quality service and long-time durability expected from Traveling Wave Antennas.

### Performance Characteristics

The following characteristics of the B-series closely resemble those of the A-series:

1. Higher aperture efficiency. In lower gain antennas, gains up to 0.9 per wavelength of aperture can be achieved.

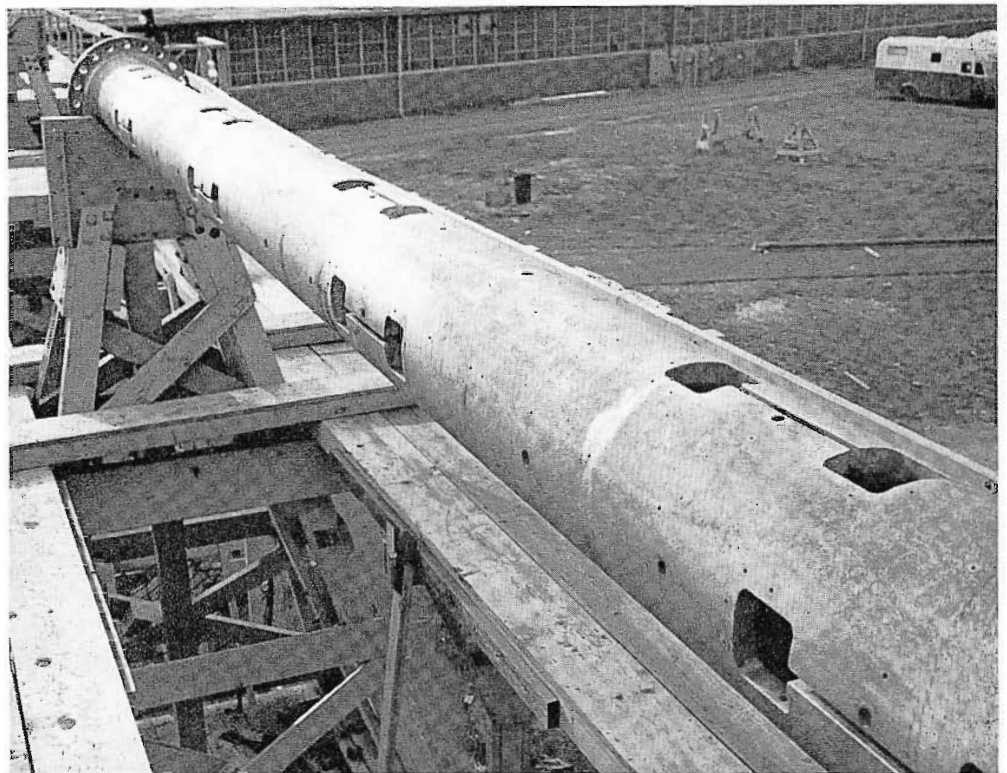

FIG. 21. This is a section of the TW-18B Channel 8 Traveling Wave Antenna which is the first of the new B-series to be built.

2. Null-free vertical pattern.
3. Variety of gains. At present, nominal gains of 9, 12, 15 and 18 are being offered.
4. Excellent horizontal pattern circularity. Similar to A-type, which have had measured values from  $\pm 0.2$  db to  $\pm 0.8$  db.
5. Low VSWR. Similar to A-type, well below 1.1 to 1, and normally better than 1.05 to 1 across the channel.
6. Input Impedance. Made for 50-ohm input impedance, and supplied with transformer for 75-ohm applications.
7. High power handling capacity. At present rated for a 50-kw TV signal.
8. Simplified construction. About half of the slots along with corresponding coupling and compensating capacitors have been eliminated.
9. Lower wind load. Results from shorter aperture length for a specified gain.
10. Weather protection. Same as A-type with optional sleet melters recommended in areas of heavy icing.

### No Compromise in Performance

The B-series Traveling Wave Antenna has been developed to give the broadcaster an additional way to tailor his VHF high-band transmitter plant to best suit his par-

ticular requirements. Especially in high-gain, high-power applications the new series of TW antennas combine the utmost economy of installation with outstanding electrical characteristics and simplified mechanical construction.

The majority of the excellent characteristics, most of them inherent to the principle, are common to both the A-series and the new B-series Traveling Wave Antennas. The proper individual slot patterns used with the turnstile principle result in an almost perfect horizontal pattern circularity, even for large pole diameters. Low input VSWR is due to the traveling-wave nature of feed in the antenna. The velocity compensation obtained by properly designed slot radiators maintains constant wavelength instead of constant velocity through the antenna for all frequencies in the channel, thus assuring proper pattern bandwidth.

The increased aperture efficiency achieved in the B-series Traveling Wave Antennas has been secured without appreciable sacrifice in the inherently null-free vertical pattern, which in most locations still provides ample signal for the service area. The lower overall height and reduced wind load due to increased aperture efficiency combined with further simplified mechanical construction result in more economy in both the antenna and the supporting structure.



# DUAL-PURPOSE 12-INCH TURNTABLE

*High Torque, Close Cuing, and Two-Speed Operation Make This Turntable Ideal for Modern Broadcast Use*

by G. C. WEILENMANN, *Broadcast and Television Marketing*

The trend toward standardization of 12-inch transcriptions plus the ever-increasing use of 45 and 33-1/3 rpm has emphasized the need for a high-quality 12-inch turntable. The type BQ-51A Turntable was designed to fulfill these requirements. It can also be used for recording and playback of RCA Magnetic Discs. The BQ-51A operates at 33-1/3 and 45 rpm, and includes all of the more desirable mechanical features of a rim-drive mechanism. Smooth, rapid starts can be obtained, which offer maximum operating convenience.

## Easy to Install

The BQ-51A, with its attractively styled cabinet provides a complete, self-contained turntable facility (see Fig. 2). Equalized preamplifiers (BA-26A) or equalizing filters (MI-11888) may be quickly installed in convenient mounting locations. A new design tone arm is furnished mounted to the mechanism, and the RCA lightweight pickup (MI-11874-4), magnetic disc cartridge (MI-11955), or any professional type cartridge, having standard EIA mounting dimensions, can be easily assembled. The tone arm is also available for use as a second arm on the BQ-51A, or it may be used with any professional type 12-inch turntable. The BQ-51A can also be obtained as a mechanism only, to satisfy custom studio installations (see Fig. 3).

## Rugged Construction

The 12-inch turntable platter and spindle assembly are held in the main support casting by oilite bearings with the thrust supported by a ball at the bottom of the spindle (see Fig. 4). A foam rubber belt around the aluminum platter eliminates resonant effects. The mounting plate of the mechanism provides a sturdy support for the mechanism, tone arm, speed selector switch, and the power on-off switch. A hysteresis synchronous motor with a two-step diameter capstan shaft drives the platter through two Hypalon idler wheels. Selection of speed is obtained by a conveniently located control knob on the top of the mechanism. The mechanism, therefore, is a complete independent operating assembly that performs very well in a cabinet or other mounting arrangement. Wow and flutter are conservatively rated at 0.25 per cent at 33-1/3 rpm and 0.20 per cent (half of



FIG. 1. This shows the multiple uses of the BQ-51A Turntable. At the top the basic turntable mechanism complete with tone arm is shown as it would be used for a custom installation. On the left the mechanism is shown mounted in a cabinet. When the BQ-51 is used as a Magnetic Disc Recorder the record/reproduce amplifier easily mounts on the inclined panel shown on the right. Finally, the BQ-51 can function as both a Magnetic Disc recorder and as a conventional transcription turntable by adding a second tone arm. This one economical 12-inch turntable adapts to any of these varied types of operation.



peak to peak) at 45 rpm. Rumble is 35 db or more below the reference of a 100 cycle test record.

Mounting provisions for a second tone arm are provided on the mounting plate, and this arrangement makes it possible to handle both the magnetic disc and the standard micro-groove recordings on one turntable.

A modern scuff-resistant cabinet available with the BQ-51A has an attractive Fabrikoid covering including cushioned spring mountings in each top corner, in addition to a Polyurethane padding.

### Self-Contained Amplifiers

Facilities for mounting the Type BA-51A Magnetic Disc Record/Playback Amplifier locates the controls and volume indicator at an optimum operating position when mounted in the turntable cabinet (see Fig. 5). Mounting accommodations are also available for the Type BA-26A Transistorized Turntable Equalizing Preamplifier, thereby permitting output at approximately mixer level from either type of disc. An amber gray blank panel occupies the panel space utilized by the Magnetic Disc Amplifier when the BQ51-A is used solely as a standard transcription turntable.

### Reduced Installation Time

A minimum installation time is involved with the BQ-51A, since the tone arm is preassembled and mounting provisions for the second tone arm and amplifiers are already contained in the mechanism as well as the turntable cabinet. The feature of the pop-up hub for 45 rpm records, which has proven so popular in previous turntables, makes it possible to enjoy maximum operating convenience. The on-off power switch located on the right side of the mechanism also disengages the idler wheels when not in use and avoids thumps. An eight foot power cord with ac plug is supplied connected to the motor terminal board.

### Designed For The Future

The BQ-51A 12-Inch Turntable becomes an excellent companion to the BQ-2B 16-Inch Turntable and reduces the studio space needed for "disc jockey" type of programming. Convenient handling of as many as four turntables, all within reach of a single operator, can be realized when using the BQ-51A. Many agencies are now releasing commercial transcriptions on 12-inch discs, and the trend is toward increasing standardization of this size. The BQ-51A fulfills the need of the broadcaster desiring a close cuing two-speed 12-inch turntable.

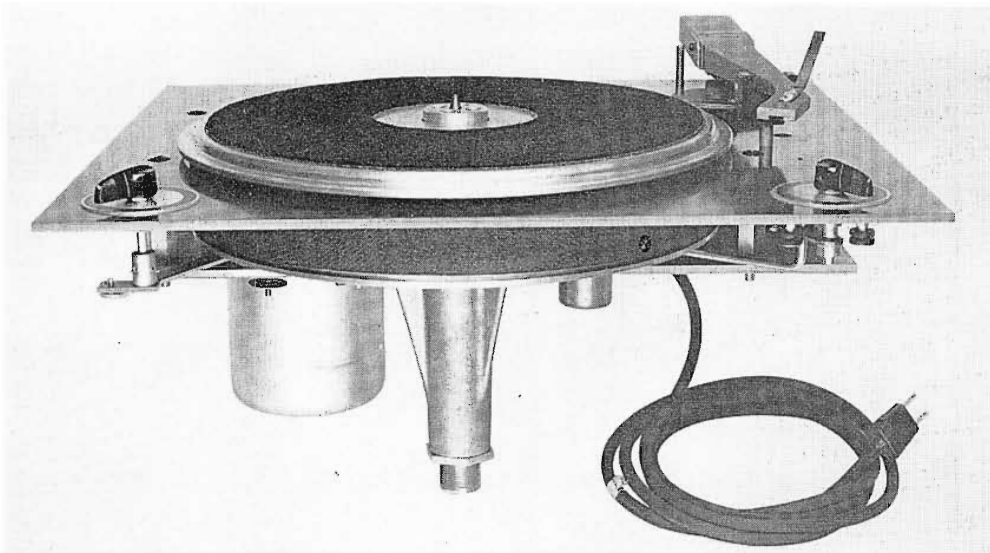

FIG. 2. The BQ-51 easily mounts in custom installations. The mechanism shown here can be mounted with no other components required.

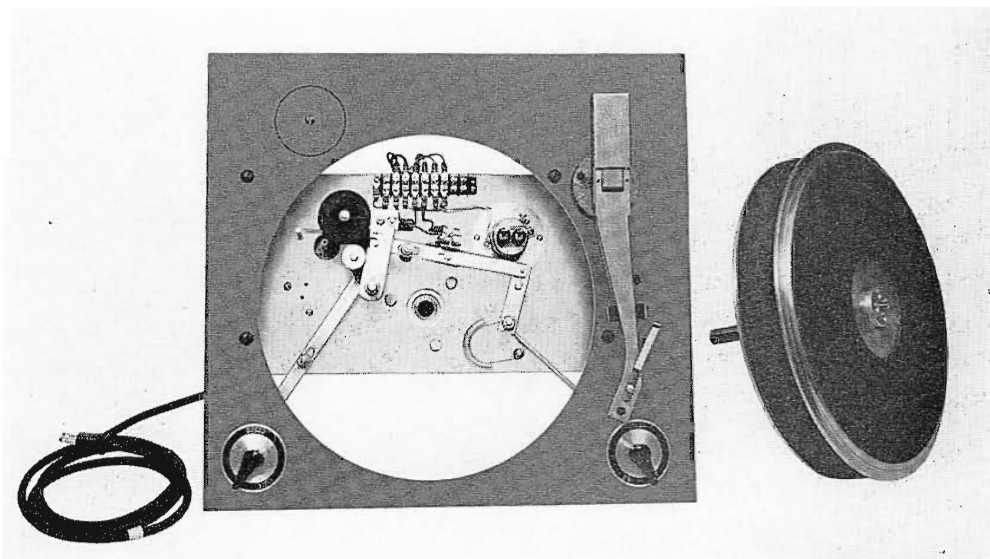

FIG. 3. The platter assembly is easily removed exposing the idler wheels and wiring terminals. Lubrication is thus simplified.

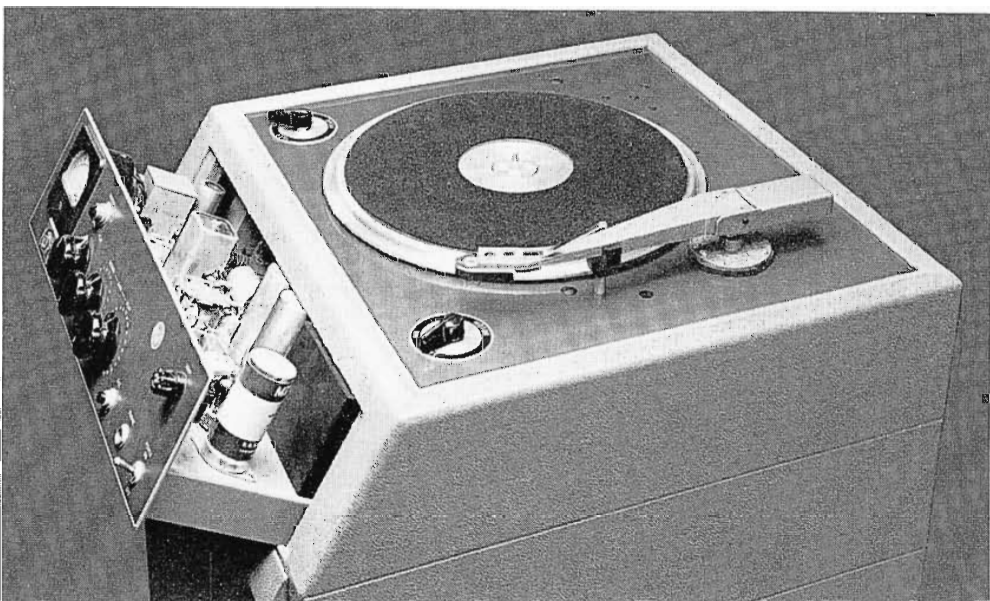

FIG. 4. This shows how the BA-51A Magnetic Record/Reproduce Amplifier is installed in the turntable cabinet and it is easily removed for servicing.



# NEW EQUIPMENT FOR MEASURING ENVELOPE DELAY

*New Technique Provides a Low Frequency Reference to Relate the Envelope Delay of High and Low Frequency Components of the Video Signal*

by EDWARD NOEL LUDDY, *Manager, Broadcast Transmitter and Antenna Marketing*



FIG. 1. Typical uncorrected TV system response of 100 kc square wave.

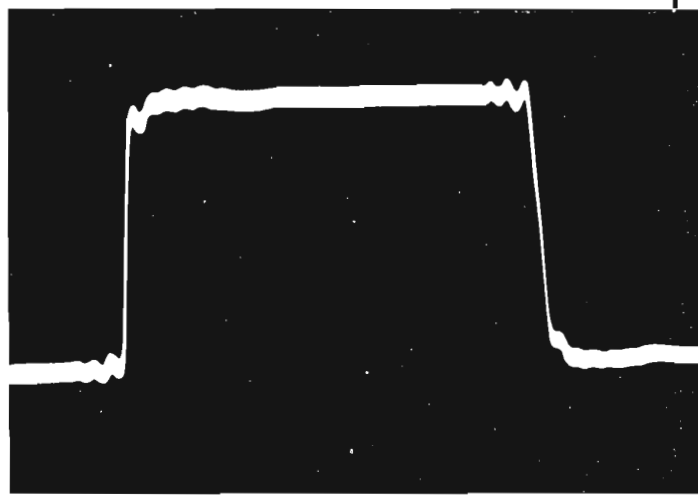

FIG. 2. Phase corrected system response of 100 kc square wave.

The envelope delay characteristic is an extremely important factor in television systems. The effect of improper envelope delay is quite pronounced in color television, but a properly corrected system is also necessary for monochrome transmission if the optimum in picture quality is to be obtained. A new measuring technique has been developed which provides a low frequency reference to properly relate the envelope delay of the high and low fre-

#### ACKNOWLEDGMENTS

The author wishes to express his gratitude to C. D. Kentner, Manager of Broadcast Transmitter Development and Measuring Equipment Design, and J. C. Chianbrando of Broadcast Transmitter Engineering for their contributions to this paper and the design and test of the BW-8A Envelope Delay Measuring Set.

quency components of the video signal. The RCA BW-8A Envelope Delay Measuring Set utilizes this new technique, and is designed for television station use.

#### Envelope Delay

The phase-versus-frequency characteristic of television systems is usually referred to in terms of time delay or envelope delay. Time delay is equal to the phase shift divided by the angular frequency ( $\phi/2\pi f$ ). Envelope delay is a somewhat more sensitive term used for expressing phase shift, and is equal to the incremental slope of the phase-versus-frequency characteristic ( $\Delta\phi/2\pi\Delta f$ ). An ideal system has a linear phase characteristic and equal envelope de-

lay at all video frequencies. The effects of improper phase relationship between the various frequencies in a television system are well known, producing leading white, trailing smear, ringing, and misregistration.

The television system used in the United States is a band-limited system of approximately 4 mc, and one sideband is partially attenuated to conserve spectrum space. Such a system has many advantages, but inherently introduces phase distortions that must be properly compensated before optimum picture quality can be achieved.

#### Phase Distortion

The results of phase distortion caused by band-limited vestigial sideband transmis-



tion are shown in Fig. 1. The anticipatory transients preceding the transitions, and the rounding of the corners of the square wave after the transitions, are due to low frequency phase distortion caused by the attenuation of the lower sideband. The ringing following the transitions is caused by the attenuation of the upper sideband and resulting phase distortion.

These defects resulting from delay distortions cannot be completely eliminated but can be reduced in magnitude. Figure 2 shows the square wave response of a system that has been corrected by means of phase correction networks in the video input circuit of the transmitter. The anticipatory transients preceding the transmission have been eliminated, and the corners following the transitions have been made square. These improvements were made by correcting the low frequency phase characteristic. The ringing has been distributed before and after the transition, and reduced in magnitude by means of high frequency phase correction.

The FCC specifies the envelope delay characteristic required in the transmission of color television signals as shown in Fig 3. The relative envelope delay throughout the video region is referred to the average delay between 50 and 200 kilocycles and is required to be constant except in the region above 3 mc which is pre-distorted to compensate for the phase characteristic of the sound notch in a typical television receiver. The tolerances are shown by the dotted lines. The transmitter is required to correct only for its own phase distortion in the low frequency region and each receiver is to correct for any phase distortion it may introduce at the low frequencies.

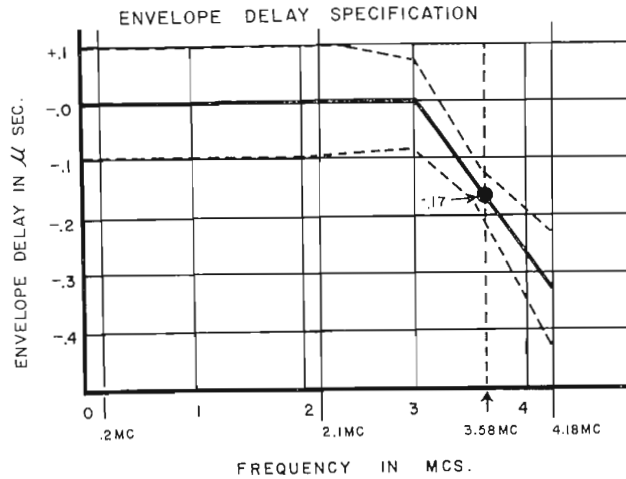

FIG. 3. FCC specification for the transmitter envelope delay curve for color TV transmission.

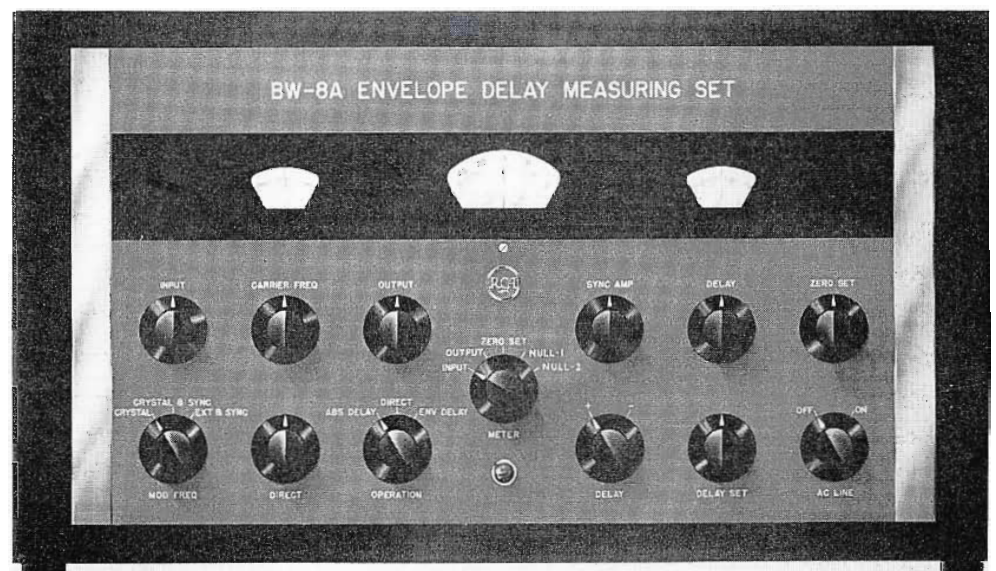

FIG. 4. This is the Type BW-8A Envelope Delay Measuring Set. All control functions are on the front panel for ease of operation.

**BW-8A Measuring Set**

There is a need for field test equipment to measure the envelope delay characteristic of television transmitter systems in accordance with FCC specifications. Quantitative measurements have been rather difficult to make in the field, and many stations have made only approximate checks by means of square wave responses. The BW-8A Envelope Delay Measuring Set, (See Fig. 4), was designed to fill this need. It is a small unit, easy to use, and provides a low frequency phase reference. The BW-8A measures the relative envelope delay in the region from 1.3 mc to 4.3 mc as referred to the average delay between 0 and 189 kc. The unit is designed for standard 19-inch rack mounting, and occupies 10½-inches of rack space.

The BW-8A Envelope Delay Measuring Set consists of a generator section that feeds the system to be measured, and a receiver section which evaluates the envelope delay

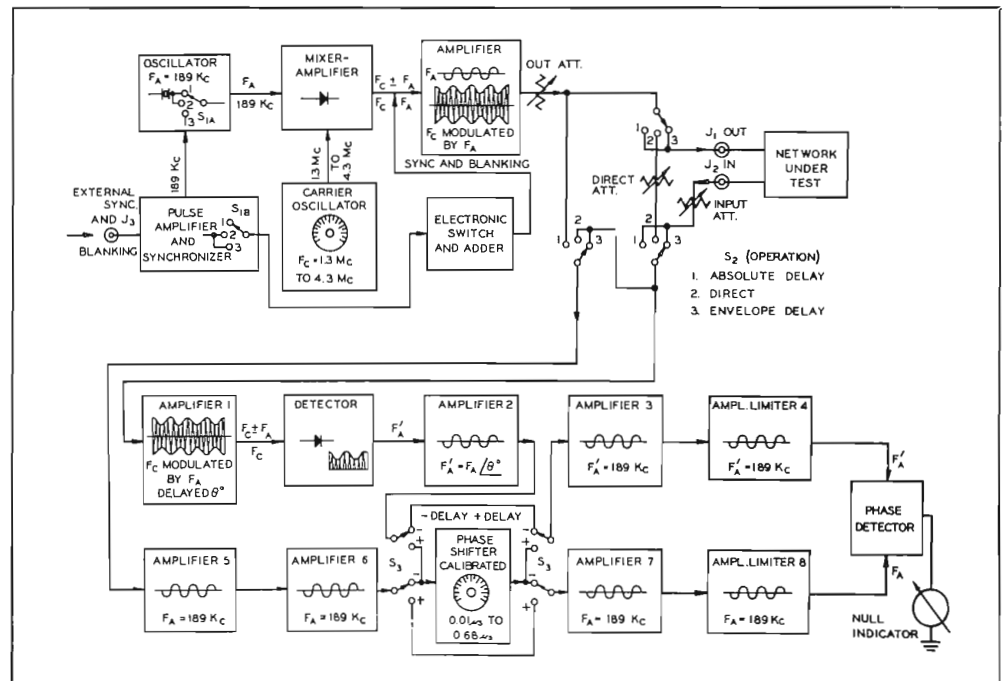

FIG. 5. Block Diagram of BW-8A Envelope Delay Measuring Set in relation to the network under test.



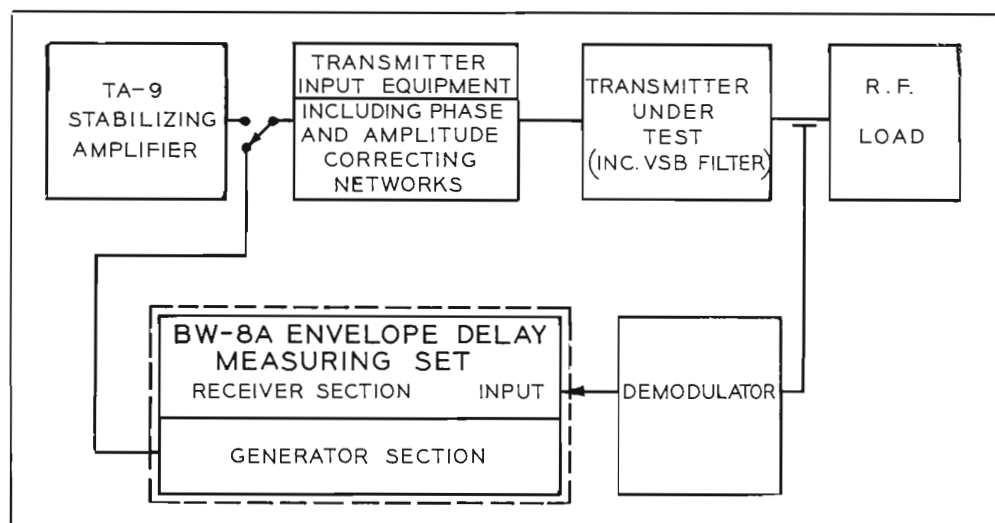

FIG. 6. This is a typical test set-up using the BW-8A Envelope Delay Measuring Set. The output of the generator section is fed to the video input of the transmitter. The output of the transmitter is demodulated to recover the video component which is then fed to the receiver section of the BW-8A Measuring Set.

of the signals after they have passed through the system under test. A block diagram of the unit is shown in Fig. 5. A fixed modulating frequency of 189 kc can be obtained from an internal crystal oscillator or can be derived as the twelfth harmonic of the horizontal sync frequency supplied from an external source. Switch S1 selects the source of the modulating frequency and adds sync and blanking if desired.

The fixed 189 kc modulating signal is fed to a mixer amplifier together with a carrier frequency that is variable in the range of 1.3 mc to 4.3 mc. This carrier is modulated to a depth of about 50 percent by a portion of the output of the fixed 189 kc oscillator. The original 189 kc frequency and the modulated carrier frequency are recovered at the output of the mixer. Sync and blanking are added if desired, and the signal is amplified.

The output of the generator portion of the BW-8A can be fed directly to the receiver portion of the unit for calibration purposes. The output of the generator is then switched to the input of the transmitter system under test and the demodulated output of the transmitter is fed into the input of the receiver section.

The receiver section is composed of two chains. The first amplifier is tuned to the modulated carrier frequency. The signal is then detected and the 189 kc modulating component recovered. The demodulated signal is amplified and fed to a phase detector. The other amplifier chain is tuned to the 189 kc signal that has passed directly through the system. This signal is also amplified and fed into the phase detector. The phase shifter consists of an RLC network and may be switched into either amplifier chain to permit compensation of either positive or negative time

delay. The phase shifter is calibrated directly in microseconds and reads the relative envelope delay between the carrier frequency and the reference average envelope delay between 0 and 189 kc. Envelope delays up to 0.68 microseconds may be measured with an accuracy of  $\pm(3\% \pm 0.01)$  microseconds.

#### Typical Test Set-up

A typical test set-up using the BW-8A Envelope Delay Measuring Set is shown in Fig. 6. The output of the generator section is fed to the video input of the transmitter ahead of the phase equalizers and low pass filter. It may be fed into the input of the stabilizing amplifier if sync and blanking are added. The output of the transmitter must be demodulated to recover the video component. A standard vestigial demodulator such as the RCA BW-4B can be used for this purpose, or a diode may be employed. The output of the vestigial demodulator or diode is fed to the receiver section of the BW-8A.

#### Envelope Delay Characteristics

The envelope delay characteristic is specified by the FCC in terms of a perfect vestigial demodulator. Standard demodulators, such as the RCA TVDE BW-4B, approach the ideal receiver characteristics within very close limits. A standard vestigial demodulator should be used to monitor television signals at the output of the sideband filter as it will provide the best indication of picture quality as viewed on good home receivers.

When fed with a vestigial sideband signal, the diode demodulator not only provides a non-uniform video amplitude response, but also a distorted phase characteristic (See Fig. 7). Although vestigial sideband signals cannot be satisfactorily monitored from a diode demodulator, it was deemed desirable

to be able to use this type of demodulator to measure the envelope delay characteristic of the transmitter system. By utilizing the diode as a check against the vestigial demodulator, the error due to a poorly aligned or poorly compensated vestigial demodulator can be isolated.

The calculated envelope delay characteristics of a television transmitter and filter-plexer combination that is not phase compensated is shown in Fig. 7. Calculated curves for both a diode demodulator and an ideal vestigial demodulator are shown. It can be seen that in the low frequency region where a double sideband signal is available the two demodulators provide essentially the same overall envelope delay. In the region where the lower sideband is being attenuated the two curves differ quite widely. After the lower sideband has been attenuated the two envelope delay curves become identical. This indicates that a diode demodulator can be used to determine the envelope delay characteristic of video frequencies above approximately 1.5 mc as compared with a reference in the range below 200 kc. This is the important region to be investigated as the envelope delay in the range from approximately 200 kc to 1.5 mc is controlled only by minimum phase shift networks as far as the transmitter is concerned. Variations in the phase characteristic of the transmitter upper sideband in this region are related to the amplitude response which is generally quite flat at these relatively low modulating frequencies. The overall video phase response in this area is largely dependent on the degree to which the demodulator that is used accepts or rejects the lower sideband.

The envelope delay characteristic of a visual modulator as measured by the BW-8A is shown in Fig. 8. The modulator



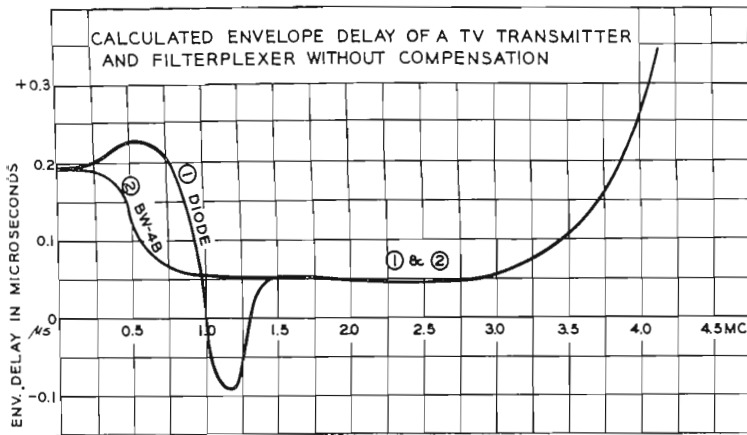

FIG. 7. Shows the calculated envelope delay of a TV transmitter and filterplexer being demodulated with a double and a vestigial sideband demodulator.

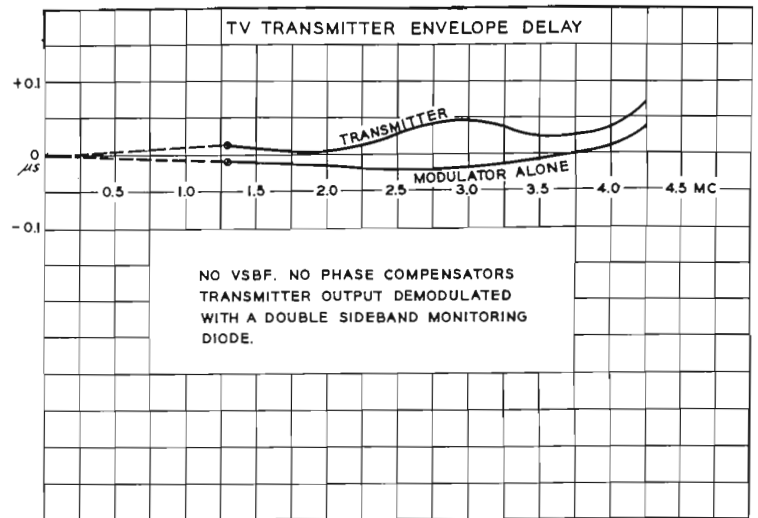

FIG. 8. Measured envelope delay of TV transmitter visual modulator and the overall transmitter characteristic.

alone contributes relatively little delay except at the very high frequency end where the frequency response is being attenuated. The overall transmitter envelope delay characteristic utilizing a diode demodulator is also shown in Fig. 8. Only minor variations in the basic transmitter envelope delay response are experienced before sideband shaping is applied.

The envelope delay of a television transmitter and vestigial sideband filter is shown in Fig. 9. No phase correction was employed in the transmitter input, and the need for about 0.15 microsecond low frequency equalization is apparent. The measurements taken with the diode demodulator and vestigial demodulator agree quite closely in the range from 1.3 mc to 4.3 mc. Either type of demodulator may be used with the BW-8A Envelope Delay Measuring Set.

The final overall envelope delay characteristic is usually taken with all phase correction networks in the circuit including properly adjusted low frequency and receiver equalizers. An overall envelope delay curve of a Type TT-11AH Television Transmitter is shown in Fig. 10. The curve shows the relative delay at various video modulating frequencies as compared with the average envelope delay between 0 and 189 kc. The FCC tolerances are shown by the dotted curves.

### Conclusions

It is vital that television transmitting systems be properly corrected for envelope delay deficiencies in order to broadcast high quality pictures. It is hoped that the BW-8A Envelope Delay Measuring Set will make it easier to test and align television transmitting systems to improve the fidelity of transmission.

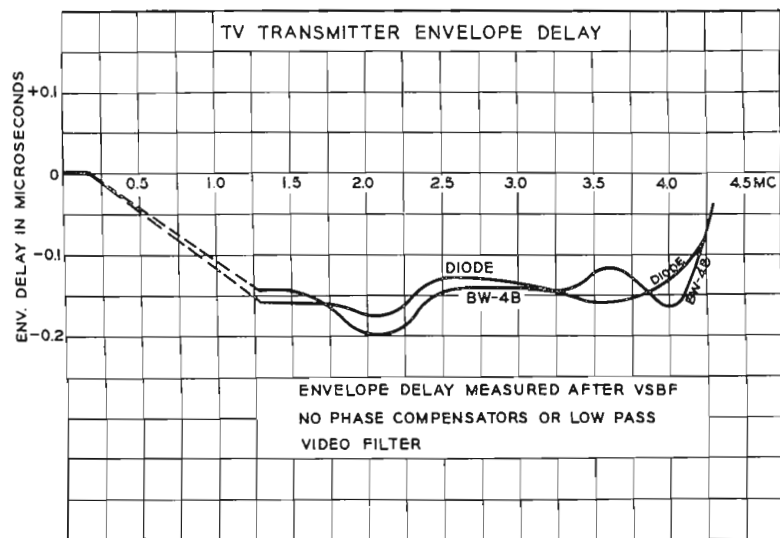

FIG. 9. Measured uncompensated TV transmitter envelope delay at output of sideband filter using both diode and vestigial demodulators.

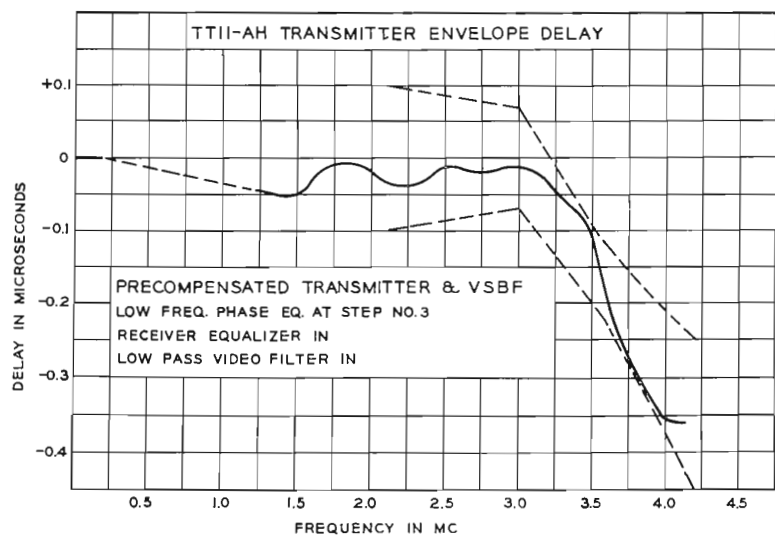

FIG. 10. Measured envelope delay characteristic of RCA Type TT-11AH Transmitter shown in relation to specification parameters.



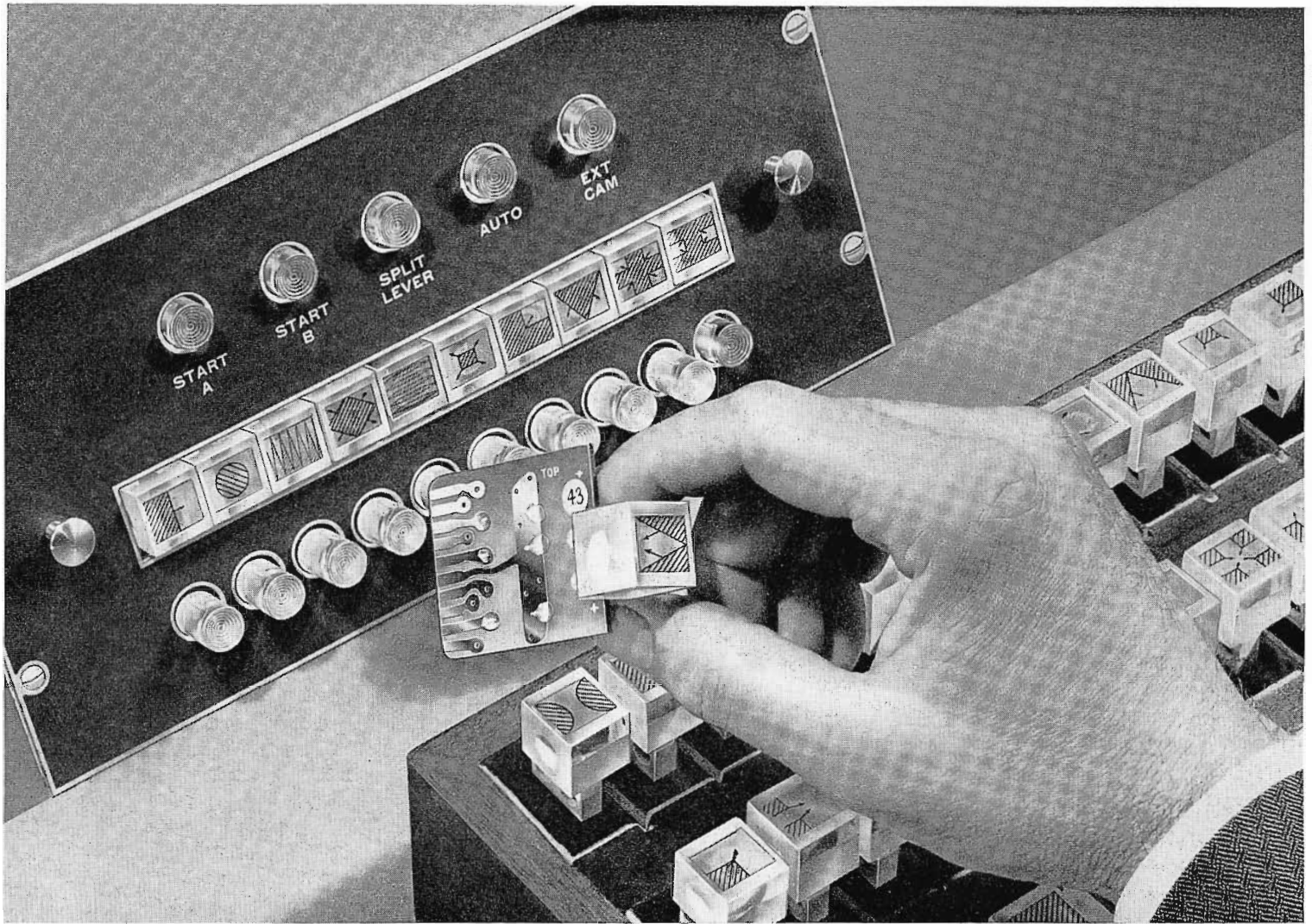

FIG. 1. Effects control panel for the RCA System. As many as 154 transitional and split-screen effects may be programmed using plug-in effects modules.

## NEW SPECIAL EFFECTS SYSTEM

*Designed for Color and Monochrome Operation, This System Offers More Than 150 Effects Via Plug-in Selectors, Single Lever Control, and Provision for External Keying*

by R. P. MAJOR, *Broadcast and TV Equipment Sales*

The new RCA Special Effects System provides the television programmer with one of the most versatile tools ever designed for making programs more effective for clients and more interesting to viewers. As many as 154 transitional and split-screen effects may be programmed. These include horizontal and vertical wipes, corner inserts, horizontal and vertical splits, rectangular, circular, and diamond-shaped iris effects and multiple frequency patterns. Also a keying signal from an external camera source can be accommodated to supply such additional

effects as inset letters, trademarks, self-keyed video insets and traveling mattes. All of these effects are applicable with color or monochrome signals or a combination of both.

The system is extremely flexible and easy to operate. The effects to be used for a given program can be preselected in advance using plug-in modules. Effects control is accomplished by a standard fader lever which simplifies operation and assumes reliability.

### Effects Control

This Special Effects System has been designed to be completely integrated into a video switching system. Actual operation is similar to normal video mixing or lap-dissolve amplifier functions. A typical video switching system containing special effects and lap-dissolve facilities is shown functionally in Fig. 2.

The Video Switching Control Panel (see Fig. 3) contains seven rows of buttons. The top two are for the A and B mixing busses;



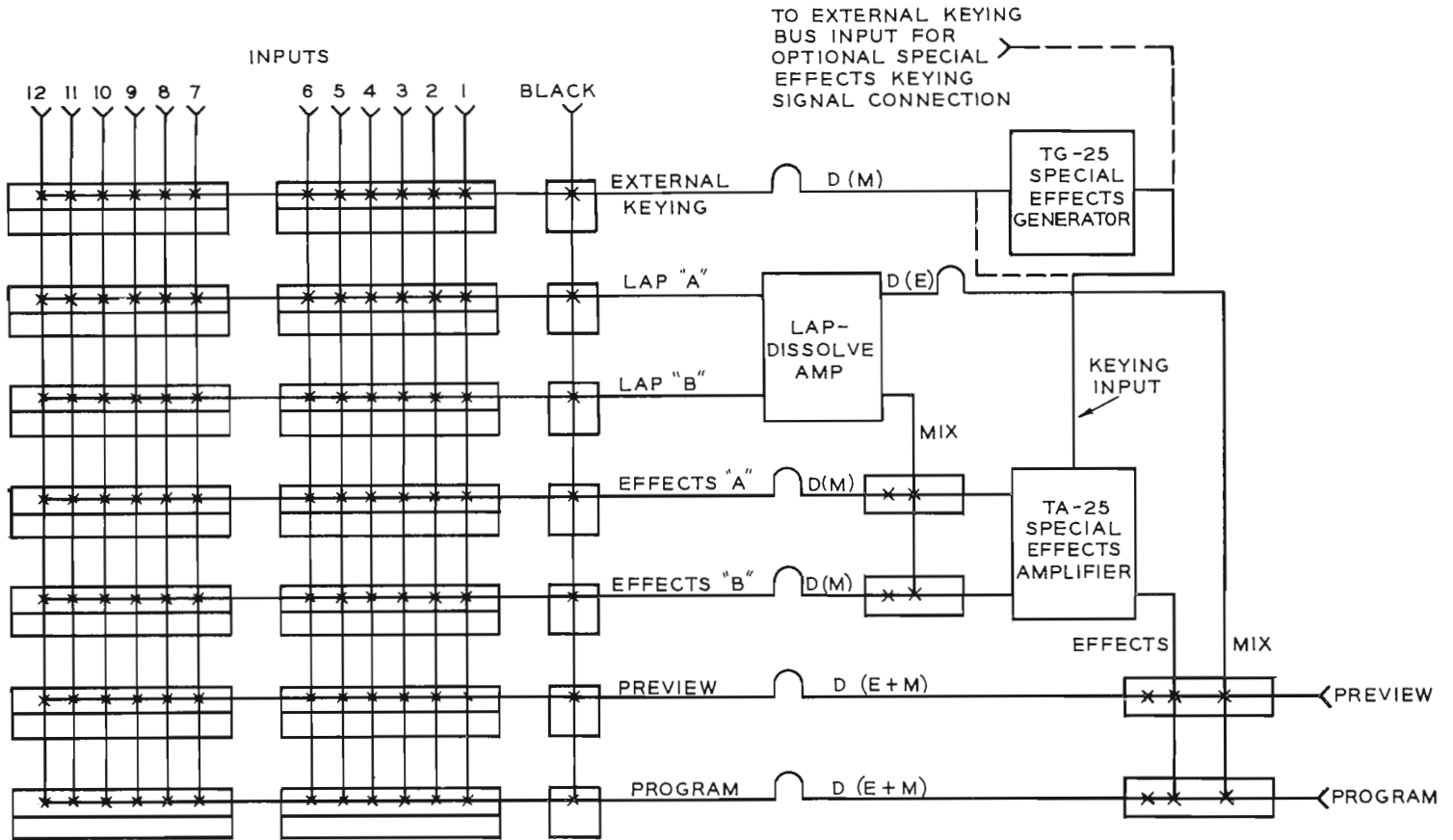

FIG. 2. Block diagram of a typical video switching system into which special effects and lap-dissolve facilities have been integrated.

the next three are for the Special Effects busses and are labeled Keying, Video A, and Video B respectively. The sixth row is for Preview and the seventh is for the Program switching bus.

An effects Control Lever Assembly is located adjacent to the A and B effects switching buttons just as Lap-Dissolve control levers are located adjacent to the A and B Mixing buttons. Note the similarity of the two control assemblies. The "touch" of each is identical, and each assembly has two actuating arms. The arms are operated either locked together or individually, the purpose of which will be explained later.

The Effects Pattern Selection Panel is shown above the Video Switching Control Panel. It should be mounted so that it is within easy reach of the operator doing the video switching. Also shown to the right of the Effects Selection Panel is a Remote Clipping Level Control Panel. It also should be mounted within easy reach of the operator.

The Pattern Selection Panel has two rows of push-buttons. The row containing five buttons is called the mode selector and the buttons are labeled AUTO, START A, START B, SPLIT LEVER, and EXTERNAL. The row of ten buttons is used to select the desired effects patterns. Above each button is a small rectangular plug-in module picturing the effect which that par-

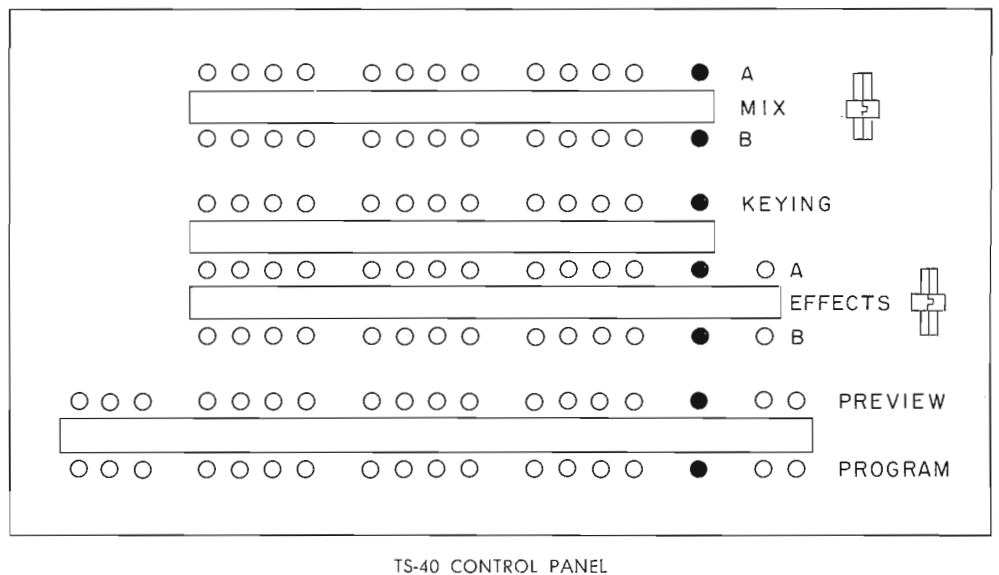
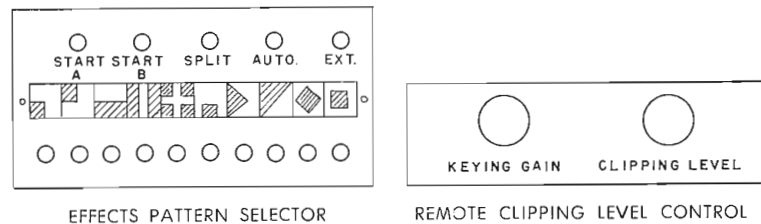

FIG. 3. Sketch of a typical switching control location. This includes a video switching control panel, a special effects pattern selection panel and a remote clipping level control panel.



ticular module will produce when the button directly below it is pushed.

Twenty modules which will produce the most frequently used effects patterns are supplied with each Pattern Selection Panel. Also supplied is a kit of parts from which an additional five modules can be made up to produce any of the 88 effects shown on the chart in Fig. 4. The 20 effects supplied with the panel are starred on the chart.

Another kit is also available to provide a set of parts for making up ten additional

effects. The kit contains a transparent sheet of patterns from which the chosen ones can be cut and affixed to the selector modules. Note that the effects patterns on the chart in Fig. 4 are all single valued functions of horizontal and vertical scanning frequencies. Only one area is keyed out of the raster for any of these effects.

Other effects in which more than one area or an area having curved edges is keyed out are shown on the chart in Fig. 5. These are known as multiple frequency ef-

fects. Ten modules for the most frequently used multiple frequency effects are supplied with the Multiple Frequency Effects Generator (see the description of the TG-25 Special Effects Generator which follows). The ten patterns supplied are starred on the chart. Again a kit of parts is supplied for making up an additional five effects. Another kit is also available for making up ten additional multiple frequency effects.

The pattern selector module, (see Fig. 1), consists of an etched wiring board fastened

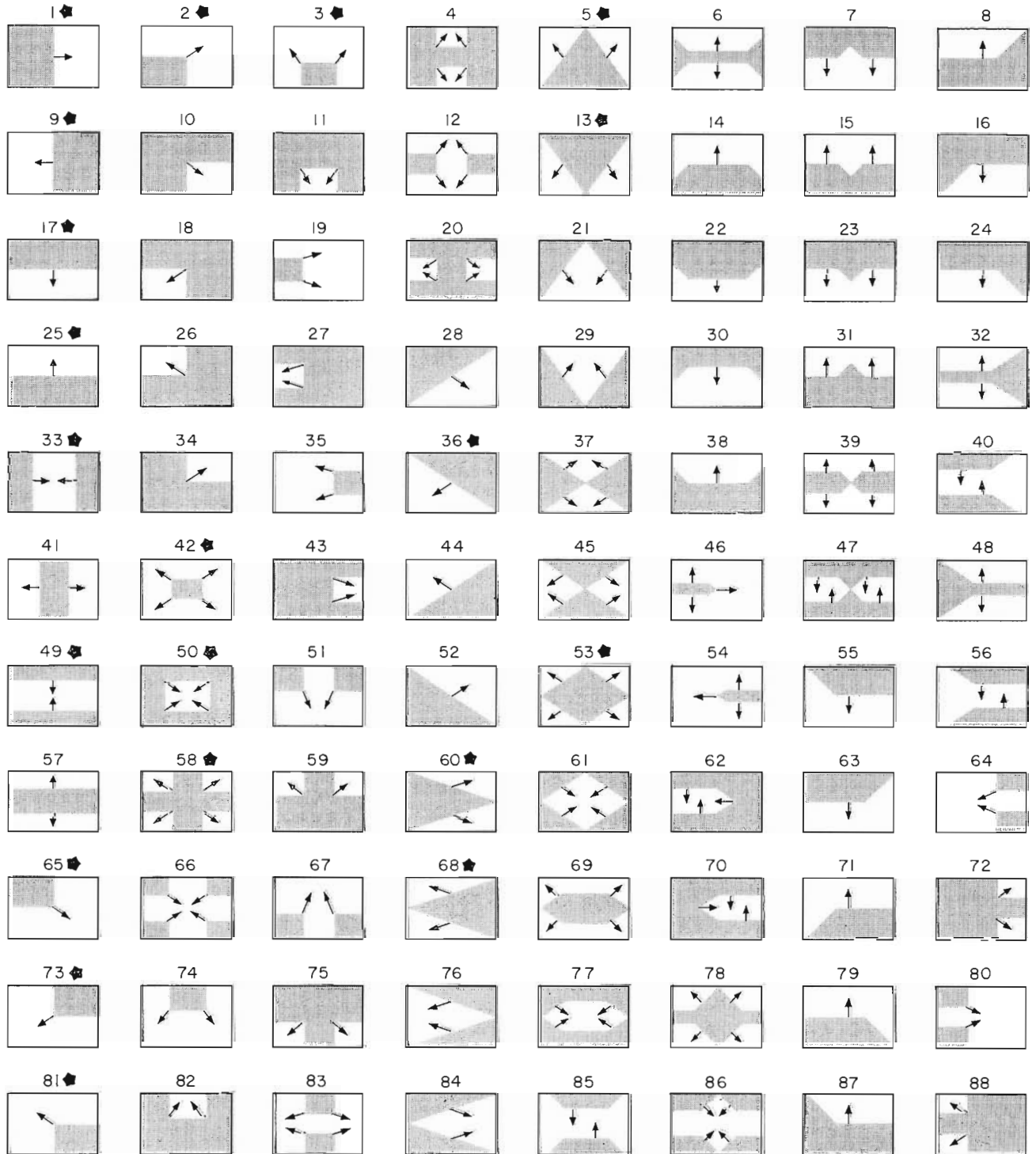

FIG. 4. All of the above effects are made possible by the Special Effects Generator, TG-25. The effects that are shown starred are supplied with each effects pattern selection panel.

to a translucent button picturing the pattern the module will produce. Semi-conductor diodes are connected between certain terminals on the board; the connections differ with each pattern. These diode connections determine which relays in the TG-25 Generator will be activated; the relays in turn determine the various combinations of pulses to produce the pattern shown on the module. For single frequency effects the board is etched on only one side; for multiple frequency effects the board is etched and diode connections are made on both sides.

The cover on the Pattern Selection Panel is removed to plug in the modules. When in position the cover serves to prevent the modules from being jarred loose by accidental bumping or brushing by the operator.

**Programming Special Effects**

The operation of the system is best explained by considering a hypothetical program. A particular program format may call for as many as ten effects. The ten patterns to be used are selected and the modules are plugged into the effects pattern selection panel, preferably in the sequence in which they will be used. Each effect is then selected by pushing the button adjacent to the appropriate effects module.

**Automatic Reverse Mode**

Assume that the first effect is to be a corner insert of picture B in picture A. After the operator is finished with it, the B picture is to wipe off the A picture leaving B filling the raster (see Fig. 6, top). Now suppose the same effect is to be used immediately thereafter, this time with a different picture source selected on the A bus to wipe picture B (see Fig. 6, bottom). To program this hypothetical sequence, the operator selects effect No. 1 (a corner insert) on the Pattern Selection Panel. Then he pushes the AUTO (automatic reverse) button in the mode selector row. Pictures No. 1 and 2 are selected on the video switching control panel to correspond to busses A and B. The output of the special effects amplifier is selected on either his preview or program channel. Making sure his control levers are opposite the A row on the switcher control panel, he moves the effects control lever assembly away from the A position toward the B position. As the lever is moved away from the A position, the arrow pointing toward the B position is illuminated. As the levers are moved the corner insert immediately appears and continues to grow in size along with the movement of the levers. The levers are stopped when the insert reaches the proper size; it remains this size until the levers are moved again.

If the insert remains for any length of time, the operator in his bustle of activity may forget in which direction he moved the levers to initiate the effect. The illuminated arrow reminds him that in order to continue his wipe so that picture 2 completely fills the raster, he must continue the lever movement in the direction of the B bus. When the levers reach the stop position the effect is completed and the light under this arrow goes out. If the wipe had

not to have been completed, he could have removed the insert by reversing the lever motion. The resulting wipe would have been in the direction exactly opposite to the original motion and the corner insert would have disappeared in the same corner whence it came.

To complete the second half of the hypothetical sequence, picture 3 is selected on the A bus. A corner wipe starting in the

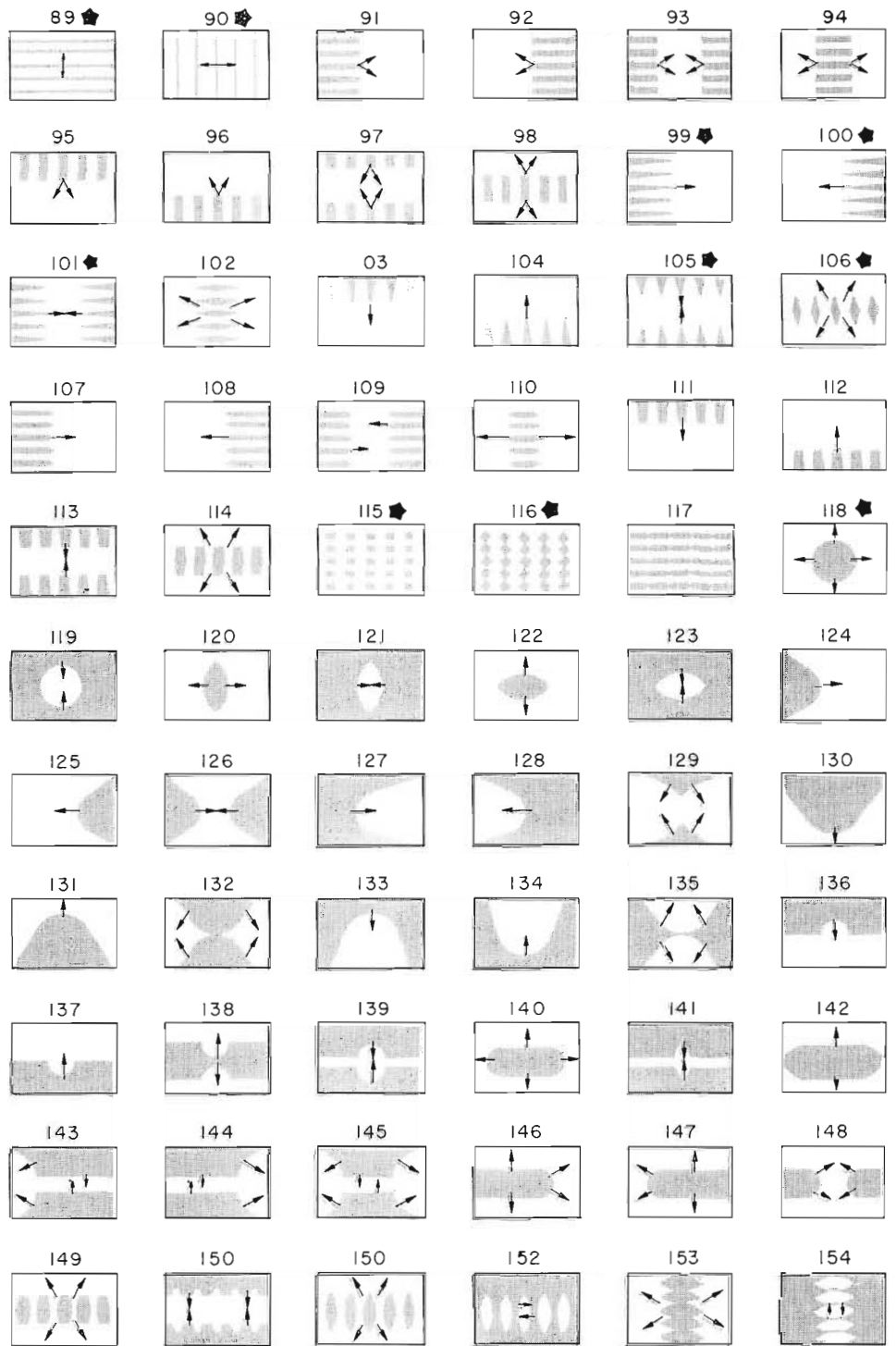

FIG. 5. Use of a Multiple Frequency Effects Generator makes possible these additional effects. The patterns which are starred are supplied with this generator.



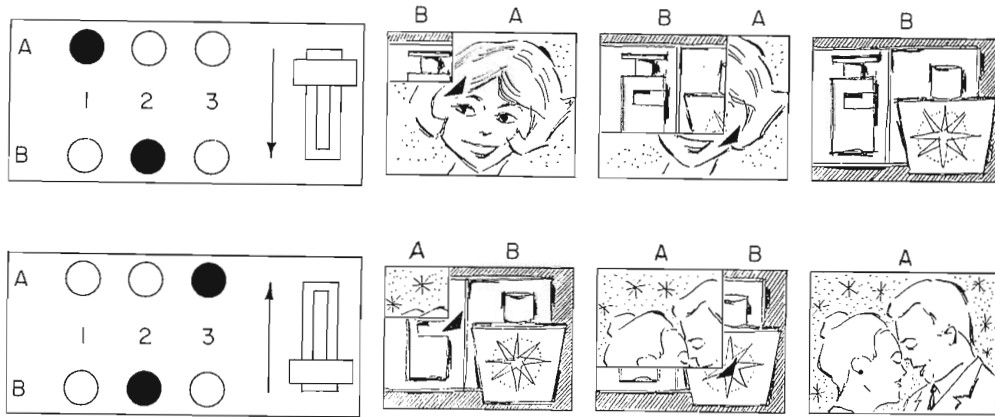

FIG. 6. Sketch showing a typical corner insert and wipe using the Automatic Reverse mode of operation. Three separate camera signals are used to complete the sequence.

same corner and traveling in the same direction will occur as the levers are moved from the B to the A position. Picture 3 on the A bus will wipe off picture 2 on the B bus from upper left to lower right. Therefore, in the AUTO mode of operation, the effect always moves in the same direction regardless of whether the lever starting position is at A or B.

For example a diamond iris wipe could be selected to start at the center of the raster. The wipe would always be from the center out. To reverse and have the wipe

from the outside in, it is only necessary to reverse the direction of the levers *before the end position is reached*.

#### A and B Modes

To depart from the automatic reverse mode, the operator may select either the START A or START B modes. Assume that a diamond iris wipe from the center out has been selected in the START A mode. If the levers are opposite the A bus, the effect will occur from the center out with picture B wiping off picture A as the levers are moved to the B position. In this mode the levers can be moved all the way to the B position and reversed, this time causing the wipe to occur in the opposite direction.

If the faders had been opposite the B bus when the START A mode was selected, moving the levers toward A would have produced a diamond wipe from outside toward the center (closing the iris) rather than from inside out (opening the iris) as would be indicated on the selector module. Therefore by providing the START A and START B options, the controls actually make 20 effects available at any given time (10 modules and the reverse of each).

#### Split Lever Mode

This mode of operation allows the aspect ratio of the pattern to be changed at the discretion of the operator. The actuating arms of the control lever can be operated separately, by releasing the latch on the handles. The arm on the left controls horizontal motion and the one on the right controls vertical motion. If a corner insert is not of the proper rectangular dimensions to include all of the subject matter, the levers can be split and the size changed either vertically or horizontally by manipulating the right and left hand levers respectively.

Also an effect can be started as a corner insert, partially completed with one lever, and finished with the other. Figure 7 shows a corner insert in which the corner insert is stretched vertically and then completed by a horizontal wipe.

#### External Keying Signals

Although the 154 patterns available constitute a wider variety than may ever be used by one television studio, there are occasions when other patterns will be required. Shapes like a shield, a star, or a keyhole may be produced by supplying a keying signal to the effects amplifier from an external camera source. This may be done by focusing a live camera on a card containing the pattern or by using a slide of the desired pattern with a film camera. To make possible the use of any picture or pattern as the source of a keying signal, provision for an effects keying bus (see Fig. 3) in the video switcher is recommended.

There are two optional connections for interconnecting the effects generator and the external keying bus to the keying input of the amplifier. In Fig. 8A, the generator output is always connected to the amplifier keying input except when the EXTERNAL button is pressed on the pattern selection panel. This button actuates a video relay in the TG-25 Generator which removes the generator from the keying bus and connects the external video keying bus directly to the amplifier input. In Fig. 8B, the output of the TG-25 Generator is fed into one of the video inputs to the video keying bus in the switcher. This bus is connected directly to the keying input of the amplifier. Thus the output of the generator is treated as another source of video signal for the amplifier keying circuits.

A simple diagram, Fig. 9, shows how keying signals are generated externally. The camera is focused on a card which consists of a black background and a white pattern or vice versa. If the background is black, the white center will be "keyed in." If the background is white, the black center will be "keyed out." In terms of the control lever operation, if the background is black the B picture is keyed in; if the background is white the A picture is keyed in. As an aid to the memory, the following formula is suggested: *B for black background to key in picture B*.

The Remote Clipping Level Control Panel is designed for use with externally generated keying signals. Signals from an image orthicon or a vidicon camera are relatively noisy compared to the rectangular keying

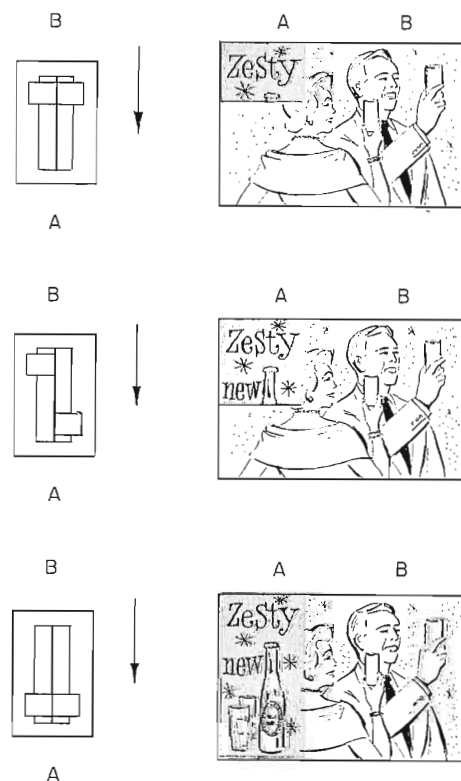

FIG. 7. A sketch illustrating operation of the split levers. A corner insert is stretched vertically and then completed by a horizontal wipe.

signals generated in the multi-vibrations of the TG-25 Generator. When the TG-25 signals are used; the keying gain and clipping levels can be set and forgotten except for routine maintenance checks. On the other hand any noise on the keying signal will cause spurious keying, resulting in ragged edges and background bleed-through on portions of the raster corresponding to those areas of the keying signal where the noise is strongest. The Remote Clipping Level Control Panel provides control over keying signal gain and clipping level so that a keying signal having optimum characteristics and waveform can be applied to the amplifier keying circuits.

Remote clipping level control becomes especially important in traveling matte effects. Here an object or person is posed before a black background with as much illumination as possible on the object and with as little as possible on the background. (Even the blackest material available reflects some light.) If now the signal generated by a camera focused on this scene is applied to both the keying signal input and to the A video input, an area corresponding to the outline of the object or person will be keyed out of whatever video signal is applied to the B input. This results in the image of the object or person being keyed into the background area.

Subject matter may move around at will before the black backdrop, and the keyed area will correspondingly move about the raster in synchronism with it. The picture applied to the B input serves as the background for the action. Thus a singer can be televised moving about the streets of Paris or on a beach or other appropriate locale. The scene can be provided by a film camera, while the performer is no farther away than the live studio. Very careful attention must be placed on lighting and the elimination of dark areas and shadows in the scene before the black backdrop; otherwise spurious keying will result. Remote clipping level control affords the operator some control over any spurious keying which may arise. An illustration of the production of a traveling matte effect is given in Fig. 10.

### Special System Features

In the functional diagram, Fig. 2, an output from the Lap-Dissolve Amplifier is shown being fed to the A and B video effects busses. This makes possible the changing of insert material (or the background for that matter) by means of lap-dissolves, fades to or from black, or even making super-impositions over insert material.

The symbol  $(-\text{C}-)$  in Fig. 2, with the notation D(E), D(M), or D(E+M), shown adjacent to it, represents a length of video transmission line (RG-11/U) which provides a time delay for the signals passing through it. This has been included in the special effects system for two reasons. First it takes a definite time for the video signals to traverse the lap-dissolve and special effects amplifiers, therefore the signals following these paths will arrive at the program output switching bus at a time somewhat later than those which arrive directly over the program bus. The delay lines are added to equalize the time delay, so that all signals arrive at the same absolute time. Second, the delay line prevents a small but noticeable horizontal shift to the right of the entire raster when a switch is made between one of the direct take inputs and the effects or lap-dissolve inputs to the program bus.

### TA-25 Special Effects Amplifier

This amplifier has a burst-sensing circuit which automatically determines on which input a color signal is present and then automatically gates the burst to the output. Thus monochrome and color signals can be mixed together without the operator being concerned about which is which for technical reasons.

The switching time in the keying circuits is extremely rapid, the transition from picture A to B and vice versa being complete in less than 0.1 microseconds. If the same signal is applied to both the A and B inputs and the levels are adjusted for the same gain and pedestal height it is difficult if not

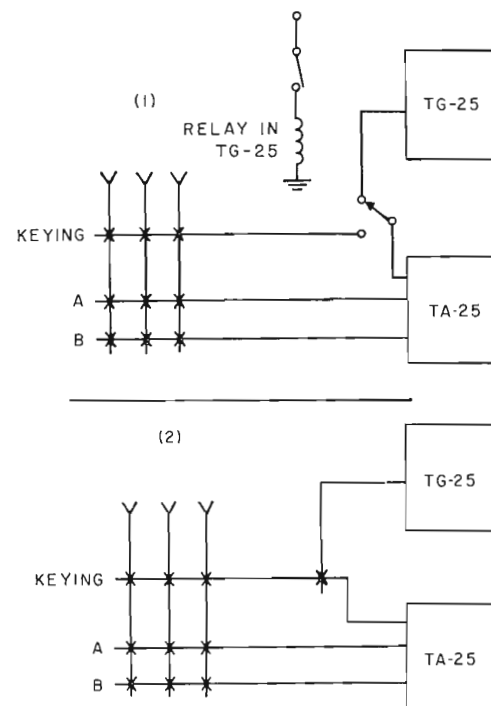

FIG. 8. Block diagrams illustrating two options for interconnecting the effects generator and the external keying bus to the keying input of the special effects amplifier.

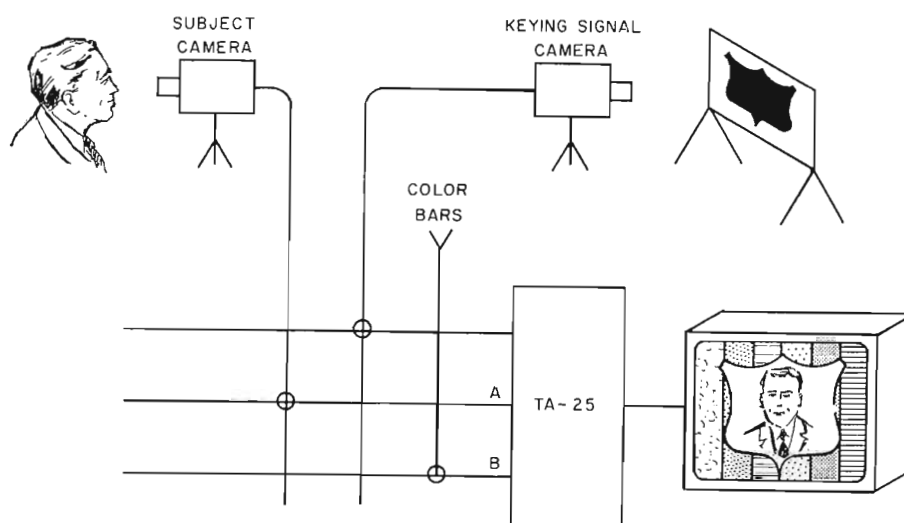

FIG. 9. Functional diagram showing how keying signals are generated externally using two cameras, a color bar generator and a typical special effects system.



impossible to find the dividing line between the A and B pictures.

The amplifier uses feedback type clamps and negative feedback to make the circuits as stable as possible. Automatic tally circuits are provided so that picture A and picture B tally output are available. The amplifier uses 45 tubes. It is built on a 21-inch bath-tub chassis. All input, output, and power connections are made at the rear and all adjustments from the front. Test points are provided for the examination of the signals at critical points.

#### TG-25 Special Effects Generator

The vertical and horizontal drive signals trigger various multivibrators and shaping circuits in this generator, creating waveforms to produce the various effects patterns. In accordance with the diode connections on the selector modules the push-buttons on the Effects Pattern Selection Panel actuate various relays which determine the type of waveforms to be used to produce the effect shown on the module. By using relays

rather than a rotary selector switch, any effect is instantly available and can actually be switched while on the air.

The various effects do not interact with each other. That is, when the generator is set up for one effect, further adjustments need not be made for the others. Also all patterns can be adjusted for linear edges. These adjustments are maintained by the stabilized circuitry and need not require attention except for routine maintenance.

The TG-25 generates all the effects which key out only single areas in the raster. These are known as the block and wedge effects (see Fig. 4). An auxiliary Multiple Frequency Effects generator generates the multiple frequency and circular effects shown in Fig. 5. These effects are generated by applying integral multiples of the horizontal and vertical driving pulse frequencies to the basic multivibrators in the TG-25. Also parabolic waveforms are generated for producing the circular iris wipe and other patterns with curved edges.

The connections (including power) between the TG-25 and the Multiple Effects Generator are all plug-in.

#### WP-25 Special Effects Power Supply

Many of the stages in both the amplifier and generator are ac coupled. Therefore to have both ac and dc negative feedback, a special power supply (Type WP-25) is used to provide plus and minus 150 volt power. A conventional 280 volt power supply is also required to provide 350 ma for the conventionally coupled stages.

#### New Convenience

The flexibility and ease of operation of the RCA Special Effects System offers new convenience in the production of programs and commercials. While it may be used effectively with virtually any good television switcher, it is particularly applicable for use with the RCA TS-40 Transistorized Switching System. In this combination it achieves utmost flexibility and maximum convenience.

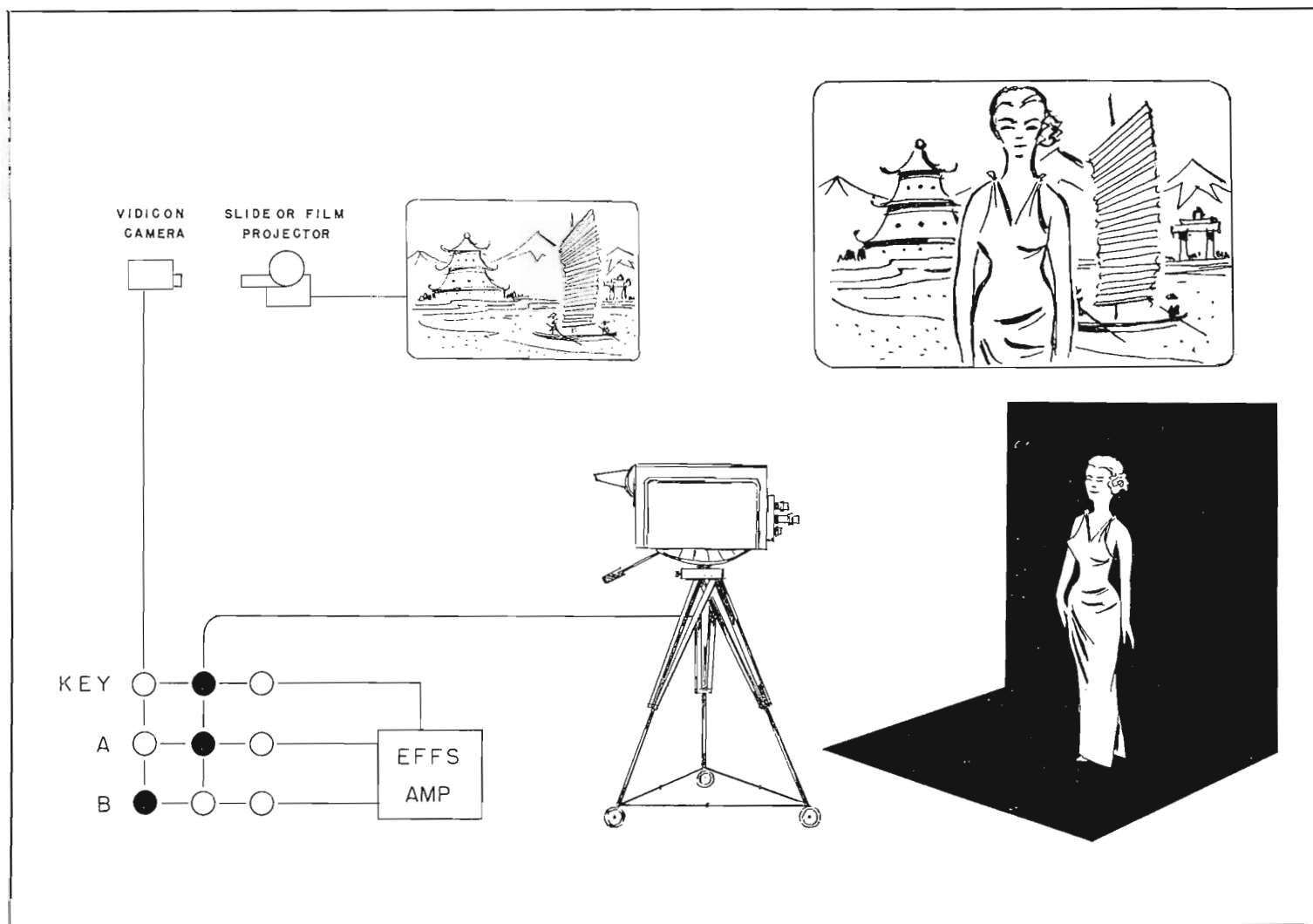

FIG. 10. Functional diagram showing the production of a traveling matte effect.

# HOW TO GET TOP PERFORMANCE FROM THE TVM-1A MICROWAVE EQUIPMENT

A TV microwave relay link provides a video highway over which the television signal may be transported from point to point, for example, from its point of origin to the television broadcast transmitter. This highway can be a smooth, streamlined conveyor of video information, or it may be a road with many "bottlenecks" — if all its component sections are not kept in good order. Adherence to a few significant operating rules will, in most cases, make it relatively easy to maintain top performance.

This article highlights those adjustments which should be given prime attention in order to get the best results from the RCA TVM-1A. This article does not attempt to compete with or replace the equipment instruction book; it does, how-

ever, supplement the book in some ways. It calls attention to certain points, and provides some illuminating background information behind others.

## Modulation — Transmitter Centering

In progressing through the microwave system, the first place where the video information can be distorted by misadjustment is in the modulation process.

The TVM-1A employs a VA-220 reflex klystron, on which the video information is to be frequency modulated. For the modulation process to be linear, as is desired, the klystron must be "centered" on the linear portion of its modulation characteristic, and the amount of frequency deviation caused by the modulator output must be within the linear ability of both the

modulator and the klystron. Figure 1 shows the modulation characteristic of a reflex klystron. Plot (b) shows how the frequency of oscillation varies with repeller voltage, and plot (a) how r-f power output varies with repeller voltage. It will be noted that the linear portion of the frequency curve is very nearly centered under the maximum of the power curve (a) plot. The proper setting for the repeller voltage (COARSE and FINE tuning) is "centered" as indicated in the diagram.

If the klystron mechanical tuning is varied, the curves (a) and (b) depicted in Fig. 1 move to the left or right as the frequency changes. The repeller voltage then must be "recentered" for the new frequency. The recentering required is slight, unless several turns of the tuning screw are made.

When sine-wave modulation (Fig. 1 (c)) is applied to the klystron, its frequency is deviated as indicated in Fig. 1 (f). At the same time the power output varies as in (d), at twice the rate of the modulating voltage, and this gives rise to the 120-cycle pattern which may be viewed at the FREQ TEST jack. The rate is doubled because the power from the klystron falls off at each extreme of deviation. (The amount of this power decrease, at normal modulation levels, is negligible and this 120-cycle pattern could not be observed were it not for the built-in amplifier stage and the gain of the CRO used in observation).

If the repeller voltage is varied to either side of the setting indicated in Fig. 1, the power output of the klystron will decrease, and the waveform observed at the FREQ TEST point will become a 60-cycle pattern. (This is because the power output will then decrease only once per cycle of modulating voltage—at one of the extremes of deviation). A decrease in power output is accompanied by a decrease in the XTAL current indicated on the panel meter in the TVM. This meter is driven by the power monitor crystal CR103 and is roughly linear in power, i.e., when the meter reading drops to half, the klystron output power will likewise have dropped to half, or by 3 db.

If the wavemeter is now tuned in and set at the center frequency of the klystron, energy will be absorbed each time the fre-

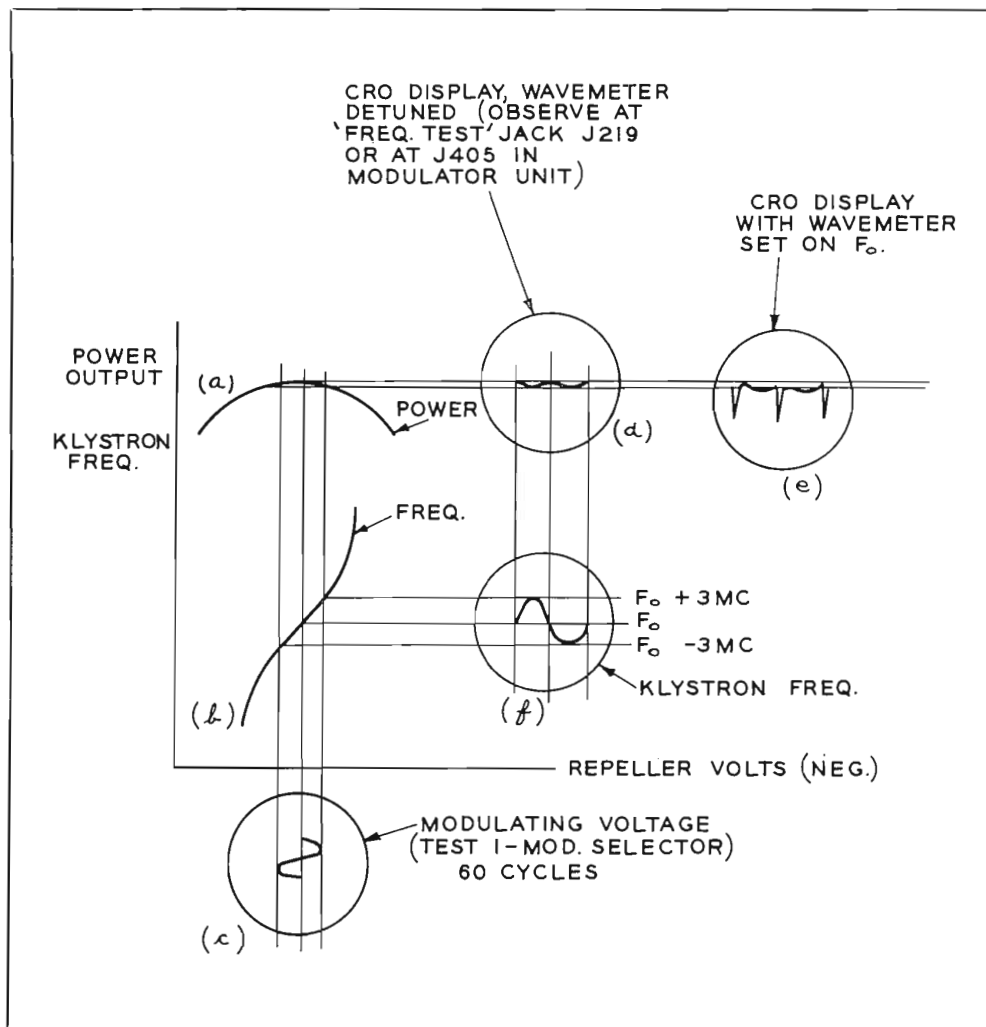

FIG. 1. Sketch illustrates how frequency modulation of the transmitter klystron is accomplished by variation of the repeller voltage. CRO display, when repeller voltage is set for maximum power output with and without wavemeter on frequency, is also shown.



quency of oscillation moves through the wavemeter frequency. Absorption of this energy reduces the drive to the crystal at the wavemeter frequency and creates the pips depicted in Fig. 1 (e).

Whenever the wavemeter pips are seen, the power monitor XTAL current as read on the front panel meter will be observed to dip. The current will remain reduced as long as the modulating voltage sweeps the transmitter frequency through the wavemeter frequency. If the modulation is removed, the CRO display will revert to a straight line and the panel meter dip will deepen. This dip will take place only when the wavemeter is exactly on the klystron frequency. This deepened dip occurs because the wavemeter then continuously absorbs energy, rather than only when the klystron is deviated through it, as with modulation.

Turning now to picture modulation, if the transmitter klystron is off "center", the noticeable result will be a stretching of either white or black, depending on the direction of the mistuning. The stretching occurs because the klystron's modulation sensitivity increases with detuning. Figure 2 indicates an off-center condition which causes white stretching. This stretching can be observed at the receiver output.

It may be noted that whenever significant stretching takes place the XTAL current will be below maximum and also the waveform at the FREQ TEST jack will have increased amplitude. Transmitter "centering" is indicated closely by maximum crystal current and by minimum video at the FREQ TEST jack, but only if there is no wavemeter present within the frequency range of the modulated signal.

The power monitor crystal detector is an amplitude detector. It shows video only when the amplitude of the r-f drive to the crystal varies with video. There is increased amplitude variation with video when the klystron is off "center" so that its power output varies with modulation, or when the wavemeter is tuned within range of the frequency deviation. When the wavemeter is within range, it absorbs power from the r-f signal each time the signal sweeps through its frequency, and this causes an amplitude modulation on the signal reaching the detector. This detected video will have a highly distorted appearance, and is not usable as picture. Its presence at the FREQ TEST jack only, indicates that there is video modulation on the transmitter, and that it is causing deviation within range of the wavemeter setting.

A final test for exact transmitter "centering" is to vary the transmitter COARSE or

FINE tuning controls and observe the TVM receiver output with receiver AFC on. The stretching indicated can then be observed, and centering is indicated when the receiver output is minimum.

### Modulation Level

The second item of importance in transmitter klystron adjustment is modulation level. If insufficient modulation is used, the signal-to-noise ratio at the receiver will be below the predicted value by exactly the amount the modulation is below normal. If too much modulation is used, then both black and white stretching could be caused at the transmitter. This effect is never encountered in practice, however, because the modulator itself begins to compress before such levels are reached.

On a system basis the first parameter affected by overmodulation is differential phase <sup>1</sup>. This will increase approximately linearly from 1 degree at normal deviation

<sup>1</sup> Measured at 3.58 mc, using normal 8 db of predistortion.

through 2 degrees when the modulation is doubled (increased by 6 db.). Next affected parameter is differential gain; however, the modulation can generally be doubled before any degradation in this is noticeable. When differential gain does start to become appreciable, it is likely to be due to compression in the modulator, as indicated in the preceding paragraph, rather than to overdeviation of the klystron.

As a practical matter, it is perfectly feasible for those users of the TVM-1A who do not transmit color, or in whose broadcast plant the differential phase has been held to very low levels elsewhere to improve signal-to-noise ratio and thus provide extra fade margin. This is accomplished by increasing the modulation of the transmitter up to 6 db and operating that way permanently.

### Transmitter — "Off Air" Monitor and AFC

High quality monitoring of the modulated carrier output and AFC of the transmitting klystron are two important optional

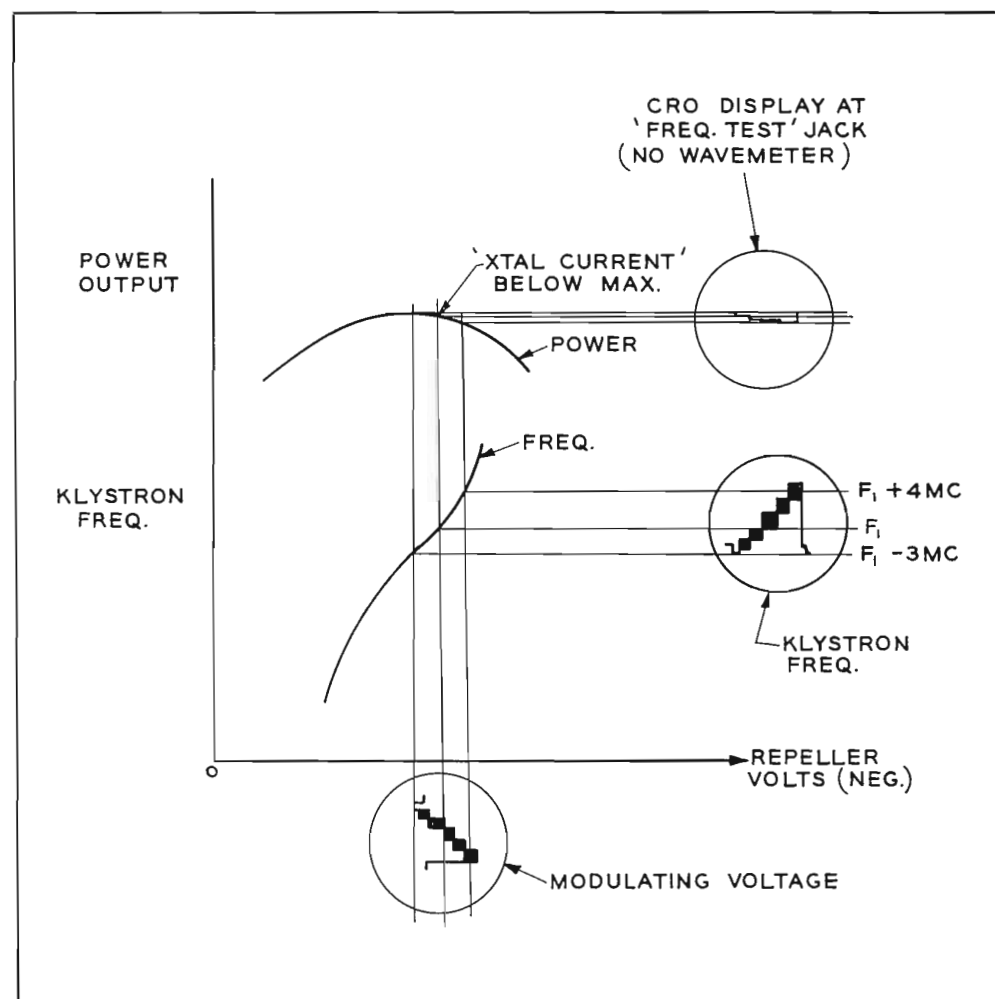

FIG. 2. Sketch illustrates how picture whites are stretched by transmitter klystron when repeller voltage setting is off "center". Off-centering of repeller in other direction—towards zero—would stretch sync and blacks.

features of the TVM transmitter. Signals required for these functions are derived from a special discriminator which forms part of the transmitter waveguide assembly. The picture signal output from the monitor amplifier is provided at the same level and quality as at the output of the receiver, thus providing a reliable check on performance of the transmitter.

In the transmitter plumbing, a small percentage of the frequency-modulated microwave signal from the transmitter klystron is diverted before it reaches the transmitter r-f output and is fed to the waveguide discriminator. This discriminator is made up of two waveguide sections and an adjustable cavity, which drive two crystal diodes, CR101 and CR102 in the plumbing assembly. The output of these diodes, in the vicinity of the cavity resonant frequency is shown in Fig. 3.

When the cavity setting is varied, the frequency at which the discriminator characteristic is centered varies, and thus the discriminator may be set at the klystron output frequency. It is noted by the fact that the discriminator d-c output (read on the transmitter panel meter in the CAV position) is zero at nominal carrier frequency, becomes positive as frequency in-

creases, and negative as frequency decreases. Also, it gives a detected video signal of the same polarity as the transmitter input signal, and with good linearity. It is observed at the junction of the cables from CR101 and CR102. If difficulty is experienced in getting d-c zero and good linearity at the same cavity setting, one of the discriminator crystal diodes may have to be changed; or occasionally the cavity may have to be slightly offset to produce good linearity and the d-c level allowed to move away from zero. Where it is necessary to offset the cavity  $\pm 0.04$  volt should be the greatest departure encountered in those TVM units where this junction is loaded by 75 ohms;  $\pm 0.08$  should be the maximum where it is loaded by 1000 ohms or more as with later monitor amplifiers and where AFC only is employed<sup>2</sup>.

Figure 3 reveals a second frequency, denoted F<sub>2</sub>, where zero d-c output is obtained from the discriminator. If the cavity is set so that this point is at the klystron output frequency, the detected video will be inverted and of less than the amplitude obtained at the proper setting. Also, a drift

<sup>2</sup> Bulletin No. 31, Code HI-273R discusses reduced loading on this junction. It may be obtained on request from Broadcast Equipment Sales.

upward in klystron frequency would result in a negative rather than a positive d-c output, and this means that transmitter AFC, attempting to work from this setting would *push out* rather than hold in. These effects are quite apparent when encountered in practice, and the "false" zero is thus readily avoided.

Depending upon the degree of unbalance in the discriminator crystals, and on the frequency of operation, the "false" zero may sometimes be at the high side of the discriminator's characteristic instead of on the low side as shown in Fig. 3. It is recognizable by the same symptoms, i.e., inverted video and AFC "push out."

Transmitter AFC will not be able to pull in from outside the false zero in either case because the error signal will have the wrong polarity. This is not a serious limitation, however, because the two zeros are generally at least 30 mc apart. Ability of the transmitter to hold-in when set on the proper zero is not affected by the presence of the false zero.

#### Receiver Discriminator

In the receiver, the signal from the antenna is converted to an i-f of 130 mc in a balanced mixer circuit and then progresses through the i-f stages and the limiter to the discriminator circuit. There the signal is detected and converted back to video. Mistuning of the receiver is often recognizable by observation of video and dc at this point,—the discriminator output, J808.

The discriminator characteristics is shown in Fig. 4. The frequency modulated i-f signal depends for its exact frequency on the setting of the receiver's local oscillator with respect to the transmitter frequency. The local oscillator should be 130 mc above the transmitter frequency,<sup>3</sup> and should be held at exactly that setting by the receiver AFC. When such is the case, the situation in Fig. 4A prevails. Here, the d-c output from the discriminator is zero, and the video sig-

<sup>3</sup> While the equipment design calls for operation of the receiver with the local oscillator above the signal frequency, it is possible to operate with the local oscillator below. This is sometimes advantageous to avoid image interference, to make use of a klystron not normally usable, or to extend operation to signal frequencies somewhat above the normal operating range.

Operation with the local oscillator below the signal would invert the video output signal from the receiver, and would cause the receiver AFC to push out rather than to hold in. Both these effects can be corrected by merely interchanging the receiver discriminator diodes, CR805 and CR806. This reverses the polarity of the discriminator and restores the receiver operation to normal.

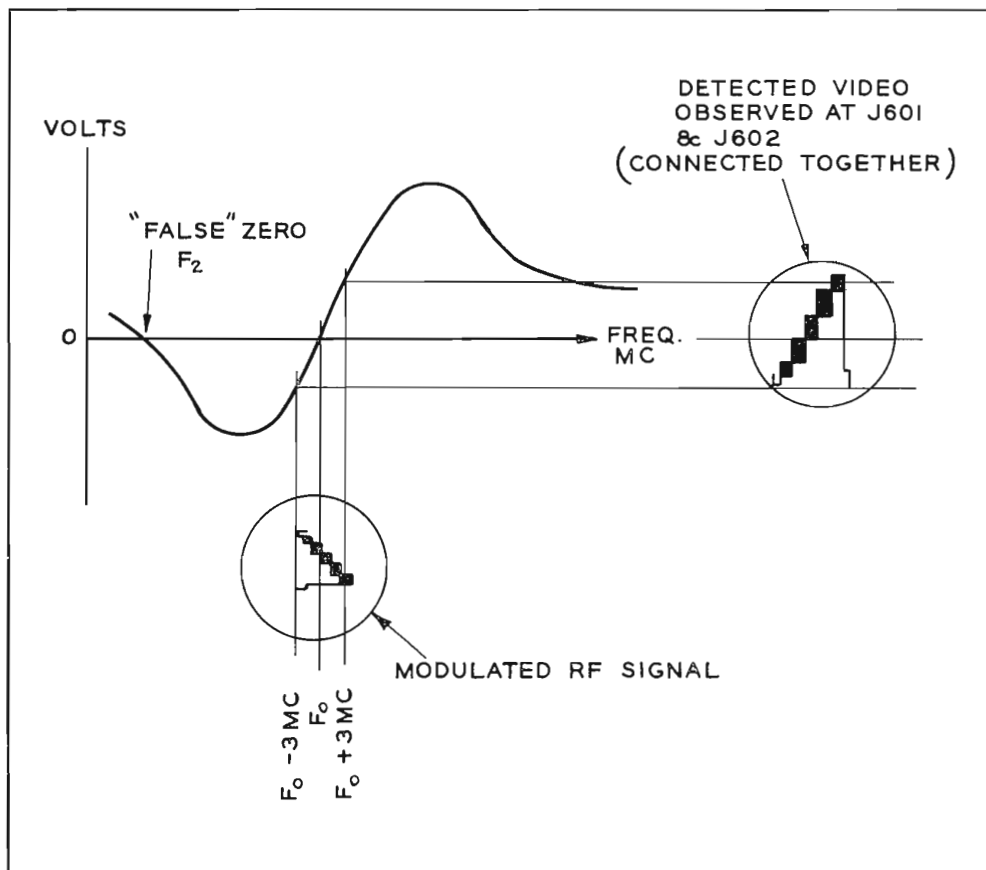

FIG. 3. Sketch illustrates correct adjustment of discriminator cavity for detecting frequency modulated signal and supplying error voltage to AFC.



nal is detected on the straight center part of the discriminator curve and has good linearity. A drift of the i-f, whether caused by transmitter or by receiver local oscillator frequency shift, causes the i-f center frequency to depart from 130 mc and this results in a d-c error voltage from the discriminator which, fed to the AFC unit of the receiver, moves the local oscillator so that the i-f center frequency is restored to 130 mc.

If there is too great a disparity between the discriminator crystals (CR805 and CR806) or between discriminator driver tubes (V805 and V806), the 130 mc point on the discriminator curve may not fall exactly at zero. In this event, the DISCRIM BAL control should be adjusted to correct this, or the dissimilar tube or crystal should be replaced.

Figure 4(b) illustrates how an off-tune receiver can center the i-f at other than 130 mc and thus cause white compression in the output of the discriminator. Such a condition can become permanent if the receiver's AFC unit holds at an error voltage significantly different from zero d-c volts. A measurement of differential phase under conditions indicated by Figure 4(b) would be greatly in excess of the value of less than 1 degree obtainable with the correct tuning of Figure 4(a).

The sharpest indicator of proper receiver tuning is differential phase. When differential phase is minimum, it follows that the receiver tuning must be such that the i-f signal is centered in the i-f stages where phase linearity is best.

If sound diplexing equipment is used, it is possible to determine this "phase center" of the i-f by noting that point in receiver tuning where crosstalk from the video channel into the audio is minimum. The crosstalk manifests itself as a sync buzz, at the vertical field rate, and can be observed by a CRO on the audio output of the sound demodulator. The level of this sync buzz, even in misadjusted equipment will generally be 40 db or more below the audio, thus it must be observed with audio modulation off.

Proper functioning (alignment) of the discriminator itself can be verified by purposely detuning the receiver with the MFC COARSE control (AFC off) first to the left and then to the right. Observe that in each case the detected video will compress, invert, and become noise in that order. If one tunes through the signal completely from left to right with a d-c VTVM connected to the discriminator output (J808),

the meter should trace the discriminator curve of Fig. 4. Peak-to-peak amplitude should be approximately 1.5 volts.

### Automatic Frequency Control

It was noted in the foregoing section that an improperly adjusted receiver AFC unit can lead to the condition of Fig. 4(b) becoming permanent. This arises from the fact that the input stage in the AFC is a balanced modulator, with an adjustable balance range to correct for differences in the two sections of the tube used (V902-12AX7). The condition of balance at zero volts d-c input to one tube may produce balance at 0.5 volt input in another. Normal setting (factory adjustment) is for balance at zero volts, and this will hold receiver tuning as in Fig. 4(a). However, whenever the balanced modulator tube is changed,

and possibly also after many months of aging, the balance control may need to be reset or the condition of Fig. 4(b) may be reached.

The need for this adjustment is indicated in a receiver when the system specification of 1 degree of differential phase cannot be met, or when "sync buzz" begins to appear in the diplexer audio output. In a transmitter having AFC the need for adjustment is indicated when with transmitter AFC off it is possible to readjust MFC COARSE or FINE to produce a higher reading of transmitter XTAL current, or a reduction in receiver video output level. (Receiver AFC must be on for the latter test). It is detected in either case by a check of the dc voltage on the coax line to J901 with AFC on. If the reading is not within  $\pm 0.08$  volts, the procedure for resetting is the following:

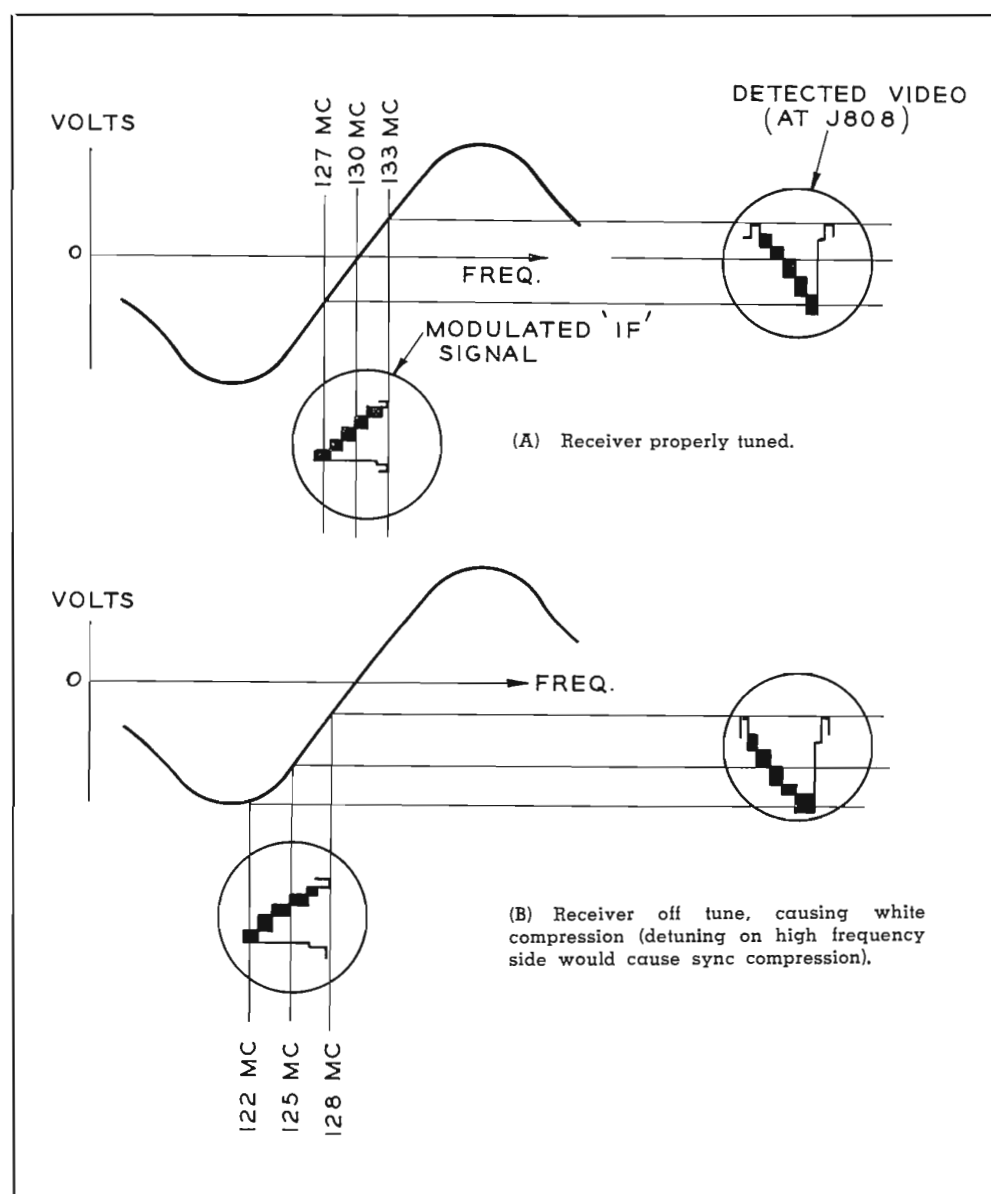
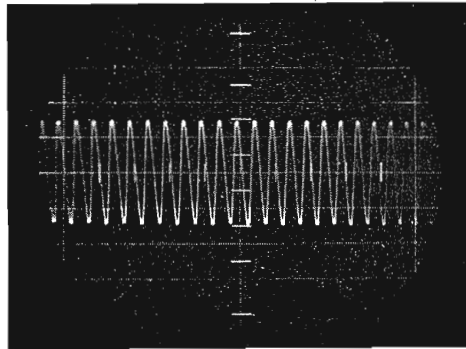
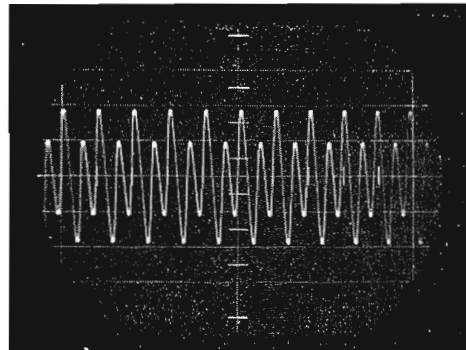

FIG. 4. Receiver IF discriminator characteristic is adjusted at factory. Whether it is utilized at center (130 mc) depends on receiver local oscillator setting, and ability of AFC to hold on zero error voltage.

(A) Balance condition. 100 kc component nulled out, only 200 kc remains.



(B) Unbalance condition 100 kc component appears.



(C) Unbalance opposite to that of (B). 100 kc component appears but of opposite phase. "Note time correlation via vertical centerline".

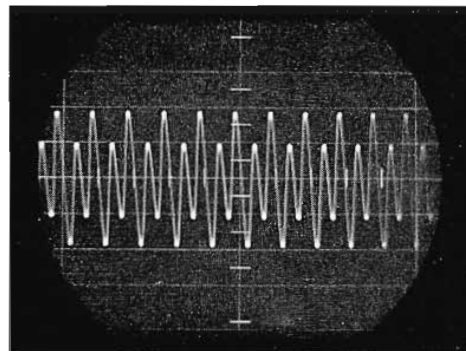

FIG. 5. Waveforms depicting balance and unbalance indication of balanced modulator in TVM AFC unit. These waveforms are observed at J902.

1. Disconnect the lead to J901 and short circuit J901
2. Remove P904 from J904
3. Turn AFC ON and adjust the MOD BALANCE control R909 (and C909 if necessary) for a null in 100 kc indication on a CRO connected to J902. Only a 200 kc display should remain (see Fig. 5).
4. Reconnect J901 and J904. Set the MFC tuning controls so that there is no correcting voltage produced by the AFC (indicated by AFC "O" on panel meter) and note that the 200 kc balance condition still prevails and that the dc voltage on the line to J901 is zero).

An attempt to manually detune the receiver (or transmitter) via its COARSE or FINE controls should show in unbalance on the CRO waveform at J902 as indicated in Fig. 5.

The AFC balance adjustment is the same on transmitter or receiver, and should always be made with the unit at *full* operating temperature. This is particularly important in the transmitter because the AFC unit is nested among regulator and rectifier tubes and undergoes a *very* great temperature change during warm-up. At least one hour of operation is recommended for full warm-up in the transmitter.

After any AFC adjustment, a check should be made to assure that the receiver holds against attempted manual detuning over at least 90 percent of the rotation of its MFC COARSE and FINE controls. In the transmitter, this range will be more of the order of 75 percent depending on the loading by the transmitter monitor unit being used.

The overall functioning of the AFC and klystron tuning circuitry in the receiver is diagrammed in Fig. 6. This diagram shows how the MFC COARSE pot selects a range of dc voltage over which the FINE pot may be adjusted. The voltage from this pot then has the output of the AFC unit added to it and the sum of these two voltages is fed to the klystron repeller.

The output of the AFC unit is measurable, though not directly calibrated in volts, by means of the AFC "O" panel meter (lower right of Fig. 6). This meter-

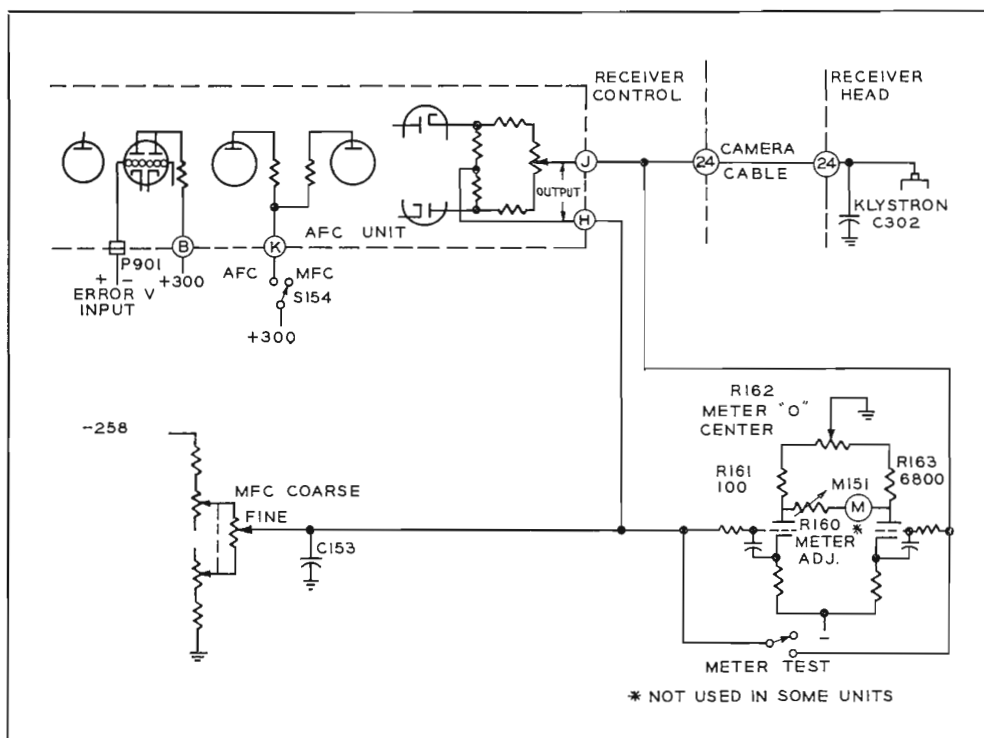

FIG. 6. AFC unit output voltage, determined by error input voltage, is measured by "O" center VTVM. This adds to MFC source voltage to hold L.O. klystron on that frequency which produces an IF resulting in zero error voltage. Transmitter tuning circuitry is virtually identical.



ing circuitry constitutes a VTVM permanently connected as shown except for the meter itself which is switched in or out of the circuit via the METER switch.

The transmitter AFC circuitry is virtually identical to that of the receiver except that the repeller voltage is higher, and the error voltage is derived from the waveguide discriminator rather than from an i-f. The transmitter AFC thus acts to hold the transmitter klystron on the cavity frequency, whereas the receiver AFC acts to hold the i-f at 130 mc as determined by the receiver's discriminator.

### Final AFC Adjustments

If it should be found that receiver differential phase is not quite optimum after the foregoing AFC adjustments, there are two possible compensating steps, either of which may be taken. The condition may arise because differential phase is an extremely sharp detector of the exact center frequency of the i-f system. The recommended step is to adjust the DISCRIM BALANCE control to reduce this differential phase (it should not exceed 2 degrees) to within the minimum of less than 1 degree. This is done with AFC on, and results in moving the point of d-c zero on the discriminator to the exact center of the i-f system.

An alternate adjustment also made with AFC ON is the one recommended in earlier instruction books, which calls for offsetting the MOD BALANCE control in the AFC unit to this point of best differential phase. It should be found at a discriminator dc which does not exceed  $\pm 0.08$  volts. In this case, MOD BALANCE is being set for balance at the discriminator d-c output of the exact center of the i-f system rather than correcting the d-c output at this center frequency to zero.

In the transmitter (transmitter monitor output) it is occasionally found that best linearity from the waveguide discriminator comes with a d-c output slightly away from zero.<sup>4</sup>

### Sound Channel

The receiver tuning which produces minimum differential phase at 3.58 mc is the tuning for best phase linearity and will therefore be found to coincide with the tuning which produces minimum "sync buzz" in the audio diplexing equipment used with

the TVM-1A. The reason for this is that phase non-linearity would be principally responsible in creating the sync buzz. This buzz is extremely low level even under conditions of misadjustment, and cannot be observed unless audio modulation is removed from the diplexer and a high gain CRO put on the audio line, or on the output of a noise and distortion analyzer connected to the audio line.

If sync buzz is audible in program sound, the buzz is practically always due to improper receiver tuning or to too high a level of transmitter video modulation.

One or two sound channels may be added to the video information being transmitted by the TVM-1A. The sound multiplexing equipments are designated as the TSD-2B and TSD-3A Sound Diplexers. They are identical equipments except for the subcarrier frequencies used, and for the interconnections provided. Both frequency modulate the audio information on a subcarrier which is then added to the program video. The B2 subcarrier is at 6.8 mc, the A3 at 6.2 mc.

Consider first the case where one sound channel is used. If sound should be observed in the picture output, it is generally due to overmodulation of the audio, too high a subcarrier level, or amplitude modulation of the subcarrier. Proper subcarrier level is approximately 20 percent of peak-to-peak video, or the minimum which permits good audio signal-to-noise to be achieved. Figure 7 (a) shows the composite waveform in a typical case.

A filter is provided in the sound modulator unit to prevent the subcarrier frequency from going back into the video signal source. Similarly, a filter is provided in the sound demodulator to prevent the subcarrier from going out into the microwave video output. If either of these filters becomes misadjusted, it may cause an amplitude modulation on the frequency modulated subcarrier leaking through it. To a viewer this amplitude modulation is more objectionable than the absolute level of the subcarrier leakage. Amplitude modulation is caused on an FM signal going through a filter if the amplitude characteristic of the filter is not *flat* over the deviation range of the FM signal. This means that the filters must be adjusted to produce a *flat* bottomed notch at 6.8 mc, about 300 kc wide. This adjustment is best made with a video sweep generator and the subcarrier both connected, first turned on alternately, then simultaneously, with sine wave modulation at full level on the sound modulator.

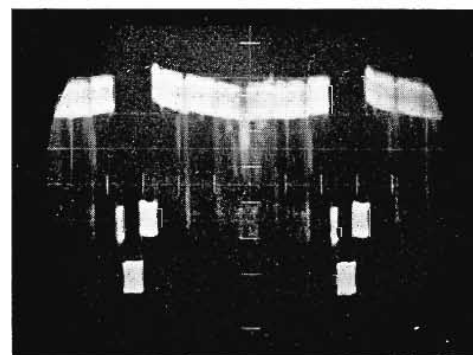

(A) Single sound channel plus picture video.

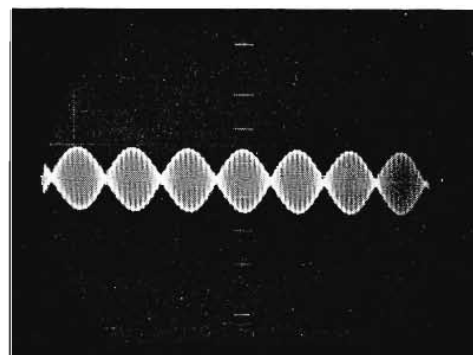

(B) Video resulting from two sound channels with equal amplitudes of subcarrier. No picture video is present, and there is no audio modulation on either subcarrier. Viewing sweep speed is 10 times that in (A) and (C). With audio modulation it is not possible to synchronize sweep speed.

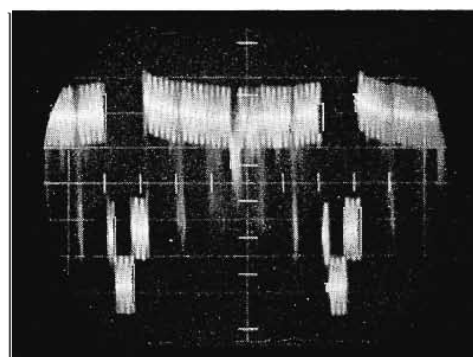

(C) Two sound channels, equal amplitudes of subcarrier, plus picture video.

FIG. 7. Waveforms of video signal resulting when one or two sound subcarriers are introduced to video line. These waveforms are observed at input to predistortion network, at J203, without interrupting the video line.

<sup>4</sup> Maxima of  $\pm 0.04$  or  $\pm 0.08$ , depending on the equipment, were indicated in the Transmitter "Off Air" Monitor and AFC Section. In this event it is desirable to adjust the AFC MOD BALANCE to hold at that d-c error voltage which produces good linearity for the transmitter monitor.

(A) Sweep response of sound diplex modulator filters. Single sound channel. First notch is at 6.8 mc, second at 7.16 mc. Waveform is observed on video line at input to pre-distortion network. Adjust C1-C4 in modulator to form notch at 6.8 mc (subcarrier is turned off in this photo).

(B) Same as (A) but with sound subcarrier turned on. Note absence of AM on subcarrier. This sometimes requires slight touch-up of C1-C4 from the (A) waveform settings.

(C) Sweep response observed at output of TVM receiver, sound subcarrier turned on. Either the sound modulator or demodulator filter is misadjusted causing AM on subcarrier. Note that misadjustment appears not to distort 6.8 mc notch. If waveforms of (A) and (B) are as shown, the misadjusted filter would be in the demodulator.

After proper adjustment waveform at this point appears as in (A), adjust C1-C4 in demodulator.

(D) Same as (C), except extreme misadjustment of one filter (note extra notch at approximately 5 mc). Trouble is probably in demodulator since increased level of subcarrier leak-thru is noticeable. Note no AM in extreme mistuning. Proper adjustment of C1-C4 will make this waveform appear like that in (A).

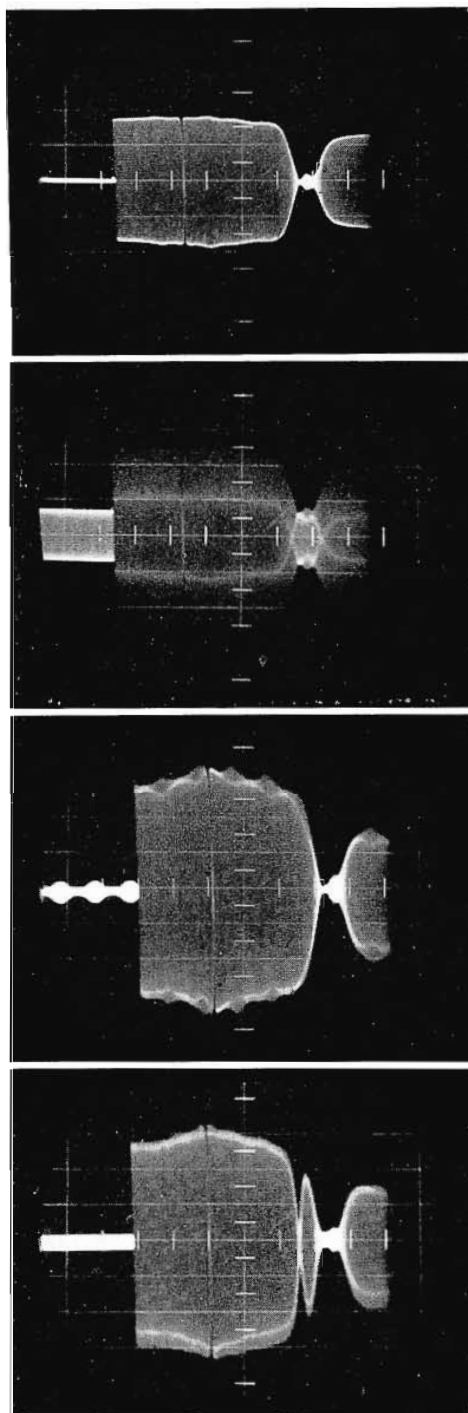

FIG. 8. Waveforms of single channel sound diplexer filter responses and alignment signals.

(The sweep generator is fed into the TVM video input). In this way both the filter notch and the AM introduced on the subcarrier can be observed, first singly and then simultaneously. The waveforms and adjustments required to restore to factory alignment are indicated in Fig. 8. (Note that a notch is provided in the modulator at 7.16 mc to prevent entry of color subcarrier second harmonic to the TVM system. This precaution, L5 and C17 in the diplex modulator, has been found of questionable value and is not included in current production).

When sound diplexing equipment is used, it may be expected that the sound subcarrier will be visible at the output of the transmitter monitor unit. This is generally not objectionable in the single-channel case, since the 6.8 mc signal is further attenuated before actually reaching the viewing monitor screen, and appears only as a fine grain structure. In the two-channel case, however, it is quite objectionable because of the beat pattern between the two subcarriers.

To remove sound subcarrier from the output of the transmitter monitor, an MI-

26398 filter is available, or a sound diplex demodulator (which, of course, contains a filter) may be installed. The latter would also provide an "off-air" sound monitor.

### Dual Sound Channels

When two sound subcarriers are applied to the TVM, the precautions to be observed for good operation are similar to the single channel case. The two subcarriers should be run so that their sum is not over 30 percent of peak-to-peak video (see Fig. 7). It is interesting to note that the addition of two sine waves (i.e., 6.2 and 6.8 mc) produces a "beat pattern" as indicated by Fig. 7(b). If this pattern is transported over a *linear* microwave system (in both phase and amplitude), no new frequencies are introduced and thus there is no picture interference. Too great an amplitude to either subcarrier or to the picture information will cause the signal to enter regions of non-linearity and the beat may then become visible in the picture output. Also, in order to preserve system linearity, both the transmitter and receiver tuning should now be more carefully centered. This is particularly true in multi-hop applications.

The requirement on filter adjustment now becomes more severe than in the single channel case, for neither filter must introduce significant AM on either its own or the other diplexer's subcarrier. The term significant is difficult to define because the permissible level of AM varies with the absolute level of RF leak-through. The filters are capable of rendering this interference absolutely unnoticeable, nominally 40 db below the peak-to-peak picture level at the receiver output. Figure 9 shows a typical dual channel filter response.

### Video Signal-to-Noise

Periodic checks of video signal-to-noise should be made at the receiver output if good long term microwave relay performance is to be achieved.

There are many contributing factors to the signal-to-noise obtainable over a microwave link. Signal-to-noise in this article is the ratio of peak-to-peak signal to *random* noise (hum, sound subcarrier, and "pick-up" should always be treated separately). The noise part of this fraction may be specified in peak-to-peak volts or in RMS volts. Peak-to-peak is more convenient, and if a wideband scope (10 mc) is available, this method will give good results when measurements are made with the scope sweep collapsed to about a  $\frac{1}{4}$ -inch width. If a Balantine 314 or other wideband (6 mc) average responding VTVM, cali-



brated in rms of a sine wave is available, a more precise measurement may be made. Conversion factor between the two is a nominal 20 db (18 db with identical bandwidth), the peak-to-peak to rms ratio always being the larger number. In any event, a CRO should always be put across the video line to examine the content of the noise.

It is possible to calculate and generally to realize within an accuracy of  $\pm 2$  db, what the signal-to-noise ratio should be over a given path. If a poorer than calculated signal-to-noise ratio is measured, and is not caused by some observable interference, it may be caused by any of the following:

1. Low transmitter power output
2. Insufficient modulation
3. Waveguide losses
4. Antenna misalignment, or
5. Poor receiver noise figure

A check which shows good signal-to-noise ratio thus assures one that many items of the system are in good condition. A poor signal-to-noise ratio, on the other hand, calls for some "detective work".

The importance of measuring signal-to-noise ratio lies in the following: Signal-to-noise ratio must deteriorate to below 44 db (24 db in peak-to-peak to peak-to-peak terms) before noise will become visible in the picture. At 28 db (8 db on peak-to-peak to peak-to-peak terms) the picture becomes unusable. This means that when noise is just below perceptible in the non-faded picture, only a 16 db fade margin remains. In terms of reliability this will indicate only 98 percent on a 25-mile path. This is intolerable for Broadcast service. For a 25-mile path the fade margin should be 37 db, which would predict a reliability of 99.99 percent. This requires a non-faded signal-to-noise ratio of 65 db, (45 db in peak-to-peak to peak-to-peak terms), and the presence of this can only be assured by measurement.

The following procedure is recommended for measuring the signal-to-noise ratio on a TVM-1A microwave link:

1. Turn off any sound diplexing equipment.
2. Disconnect any video input from the transmitter, and terminate the VID INPUT jack in 75 ohms.
3. Switch transmitter MOD SELECTOR to the TEST 2 position. This sets transmitter deviation at 2.4 mc

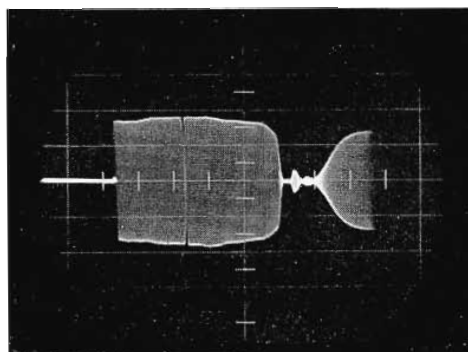

(A) Same as 8(A) but for dual channel sound. Note three notches in response, at 6.2 mc, 6.8 mc, 7.16 mc (7.16 mc notch).

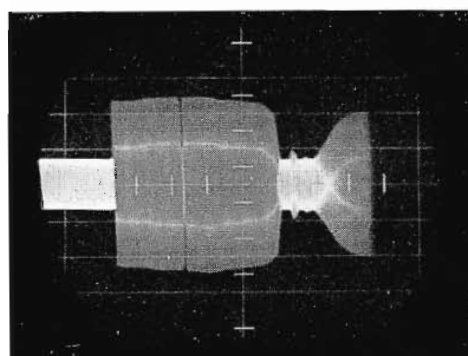

(B) Same as 8(B) but for dual channel sound. Only one (either) subcarrier turned on.

FIG. 9. Waveforms of dual sound channel filter responses and alignment signals. When overall swept filter responses are viewed at receiver output, and filters are in proper adjustment, their response should appear as in (A), except that the individual notches may more nearly blend into one. At the receiver output the response pattern is unaffected by whether subcarriers are turned on or off if demodulator filters are properly adjusted.

peak-to-peak. It is generally advisable to check this <sup>5</sup>. The predistortion and restoration networks are left in place.

4. Set the receiver OUTPUT LEVEL control to give a 1.5 volt peak-to-peak signal as measured on a CRO across a terminated output.
5. Switch the transmitter MOD SELECTOR switch to PIX.

6. Measure the level of noise at the receiver output. This may be done using either a wideband (10 mc) CRO like the Tektronix model 524, or an average responding wideband (6 mc) VTVM, calibrated in rms of a sine wave like the Balantine 314. In any event, a CRO should be connected across the receiver output to verify that the "noise" being measured is purely random.

(a) If the CRO is used for measuring, it should be set for 60-cycle

<sup>5</sup> See Instruction Book, JB-36257, which is supplied with TVM-1A Microwave Relay Equipment.

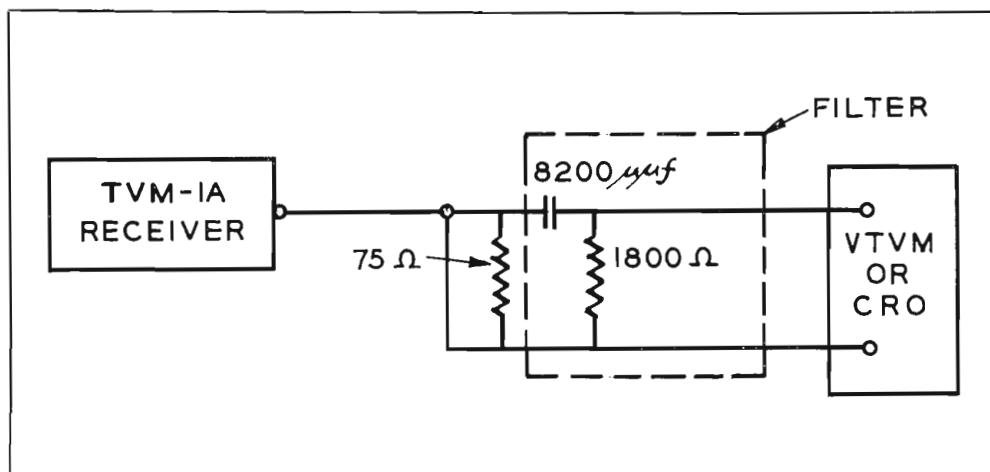

FIG. 10. Arrangement for measuring random noise showing R-C filter connection for blocking hum from measurement.

sweep, with the sweep collapsed to about  $\frac{1}{4}$ -inch width. The peak-to-peak amplitude of noise may then be read from the CRO screen, and the peak-to-peak to peak-to-peak signal-to-noise ratio in db calculated from:

$$S/N = 20 \log \frac{1.5}{\text{p/p noise volts}}$$

- (b) If the VTVM is used, its scale may be read directly and the peak-to-peak to rms signal-to-noise ratio in db calculated from:

$$S/N = 20 \log \frac{1.5}{\text{rms noise volts}}$$

The (b) method of measurement yields a number which will be 20 db larger than the (a) method for a given situation. This is because the rms value of a given noise level is less than its peak-to-peak value. The 20 db figure may be used for a conversion factor between the two methods of measurement.

If, in either measurement, any significant amount of hum is observable, then the

noise measurement should be made through a filter which will eliminate the hum. Such a filter is indicated in Fig. 10. The filter is removed when measuring signal amplitude.

#### Multi-Hop Installations

In multiple-hop installations it is especially important that the AFC/Radiation Switch (MI-26442) be checked periodically. With proper functioning of this unit, receiver AFC will be disabled upon loss of transmitter signal. This prevents receiver tuning drift in the absence of transmitter signal, and thus assures resumption of service after the transmitter signal is restored.

The AFC/Radiation Switch is a highly reliable unit, and the operation test is easily performed as follows:

1. Switch receiver AGC off.
2. Reduce IF GAIN until SIG LEV meter reaches zero. At this point the relay in the AFC/Radiation Switch should operate.
3. If the relay does not operate, the TRIP LEVEL control in the unit should be reset.

4. Finally, turn AGC on and have the preceding transmitter turned off to see that the relay operates.

Wherever the MI-26442 unit is employed the receiver AFC switch is left in the MFC position during operation. AFC is then turned on by the MI-26442 only when signal is present. The receiver COARSE and FINE tuning controls should be set so that the receiver is manually on frequency. This is indicated when the controls are set so that the AFC "O" meter reads zero with AFC on.

There are, of course, many more words which could be written about the numerous configurations of TVM-1A multi-hop systems and the accessory units they employ. These will be dealt with in a future article. It is hoped that this present article may serve to assist the user in obtaining the fine performance which this TVM-1A equipment is capable of rendering in its basic service—the straightforward and reliable relaying of TV signals.

## HINTS FOR GOOD MICROWAVE PERFORMANCE

### 1. CENTER THE TRANSMITTER KLYSTRON TUNING ON THE LINEAR PORTION OF ITS MODULATION CHARACTERISTIC.

Approximate indications are maximum transmitter crystal current or minimum video at FREQ TEST jack with *wavemeter detuned*. Adjust transmitter COARSE and FINE tuning.

Exact indication is minimum video from receiver (receiver AFC ON). Adjust transmitter COARSE and FINE tuning.

### 2. ANTENNA ALIGNMENT MUST GIVE GOOD S/N PLUS AMPLE FADE MARGIN.

Indicated when

$$S/N = 127 - \text{path loss} + \text{transmitter antenna gain} + \text{receiver antenna gain} - \text{waveguide losses.}$$

(S/N indicated is p/p video to rms noise — see text).

### 3. CENTER THE RECEIVER TUNING FOR GOOD PHASE LINEARITY.

Indicated when differential phase display is symmetrical and 1 degree or less at 3.58 mc.

### 4. AFC MUST HOLD RECEIVER TUNING.

Indicated by ability to hold against 100 percent rotation of MFC tuning controls.

### 5. KEEP PROPER MODULATION LEVELS; PROPER RECEIVER OUTPUT LEVELS.

Indicated by deviation measurement. Should be 6 mc with predistortion removed. Re-insert predistortion. Set receiver OUTPUT LEVEL to 1.5 volts p/p.





# WTQP MODERNIZES ENTIRE AM TRANSMITTER PLANT



Clyde M. Hunt, Vice President, Engineering, The Washington Post Broadcast Division.



Granville Klink, Jr., Chief Engineer, WTQP, WTQP-FM, and WTQP-TV.

**New 50-kw Ampliphase and New 10-kw Auxiliary Transmitters Have Been Installed for Remote Control Operation**

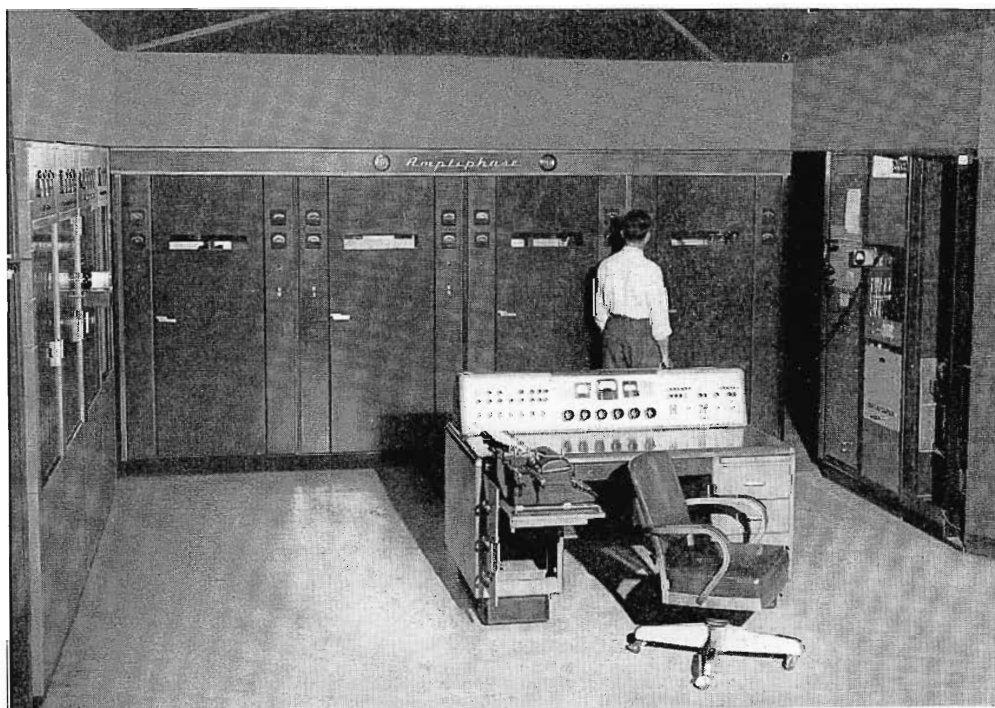

FIG. 2. All operating equipment is concentrated in the center of the circular transmitter room. The 10-KW BTA-10H Transmitter can be seen on the left, and the Ampliphase 50-KW Transmitter cubicles are in the center. Phasing and input equipment is on the right.



FIG 1. This is the WTOP Transmitter building in Wheaton, Maryland. The main section of the building is curved in a circular shape. The style of this building reflects the era of public show place transmitter plants.

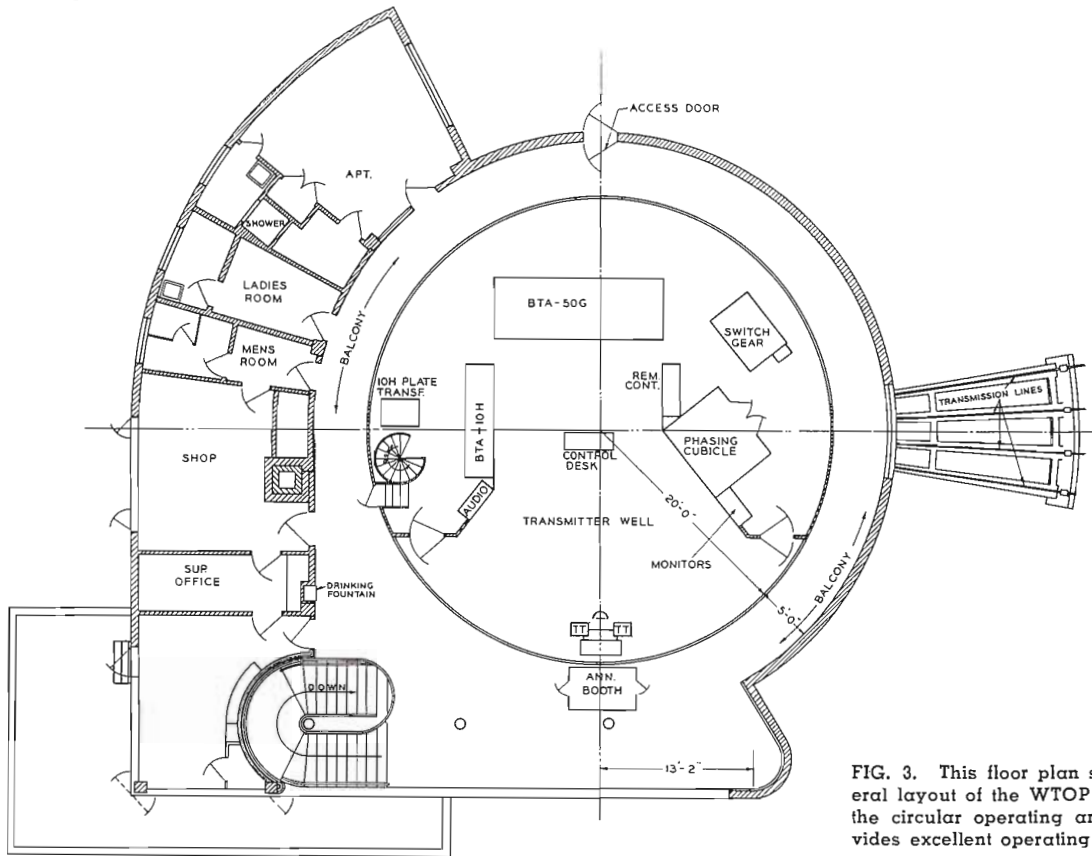

FIG. 3. This floor plan shows the general layout of the WTOP building. Note the circular operating area which provides excellent operating convenience.

The Washington Post Station, WTOP, will begin operation of its AM facility by remote control upon receipt of approval by the FCC. The transmitter plant is located just outside the nations' capital in suburban Wheaton, Maryland. Studios are at Broadcast House in Washington, where WTOP, WTOP-FM and WTOP-TV share a very modern broadcasting facility.

#### Transmitter Building

The WTOP transmitting plant was constructed in 1939 when a large building, open to the public, was a desirable feature. The transmitting equipment was installed in a well in the center of the building. This made it possible for visitors to view the entire installation from a glass paneled balcony around the well. The style of the building reflects its era (see Fig. 1).

The two new transmitters are arranged in the form of a horse shoe in the well (see Fig. 2). The terminal audio equipment is located on the left hand end of the horse shoe with phasing, monitoring equipment and test gear on the right. A curtain wall is installed around the top of all equipment cubicles. This produces a functional built-in type of appearance. The supervisors office, workshop, rest rooms, and a small apartment are entered from the balcony around the well (see Fig. 3).

Since WTOP's former 50 kw transmitter was water-cooled, the station has been able to reclaim much of the building's basement area that contained water cooling equipment. The Ampliphase Transmitter requires only the use of the transformer vault. Other equipment including power switch gear for the commercial ac mains and the 95 kw gasoline generator were not disturbed from their original basement positions.

#### Ampliphase Installation

One of the problems for the high power broadcast station is to install new transmitting equipment using the same floor space occupied by the old gear. With WTOP, a 24 hour broadcast schedule further complicated matters. This problem was solved by first installing a new BTA-10H Transmitter in the area in front of the old 50 kw Transmitter. While the 10 kw unit handled the 24 hour air schedule, the old 50 kw was dismantled to make way for the new Ampliphase Transmitter. Operation on 10 kw for a minimum period was desirable so the Ampliphase had to be installed as quickly as possible. The design of the BTA-50G lends itself readily for quick installation. The four cubicles, minus their crates, were put in slings and a small crane

lowered them through a second floor door at the rear of the building.

The floor in the transmitter well had been previously outlined with masking tape to indicate the exact position of each cubicle. When all cubicles were in their proper positions, installation was begun immediately.

The duct work for air handling was completed in five days. The system includes a louvre in the exhaust which is thermostatically controlled. Whenever the temperature in the "transmitter well" drops below a given value, the exhausted hot air from the BTA-50G is emptied into the operating area for heating purposes. The electrical contractor completed work in approximately two weeks, with the greater part of the electrical construction being done during the normal workday.

After the BTA-50G was tuned up on the dummy load, it was switched to the antenna array. When the routine adjustments of the various units had been completed, the proof of performance measurements indicated all RCA technical specifications, as well as FCC requirements, had been met.

#### Installation of the BTA-10H

To accommodate the 10 kw auxiliary transmitter for its temporary installation,



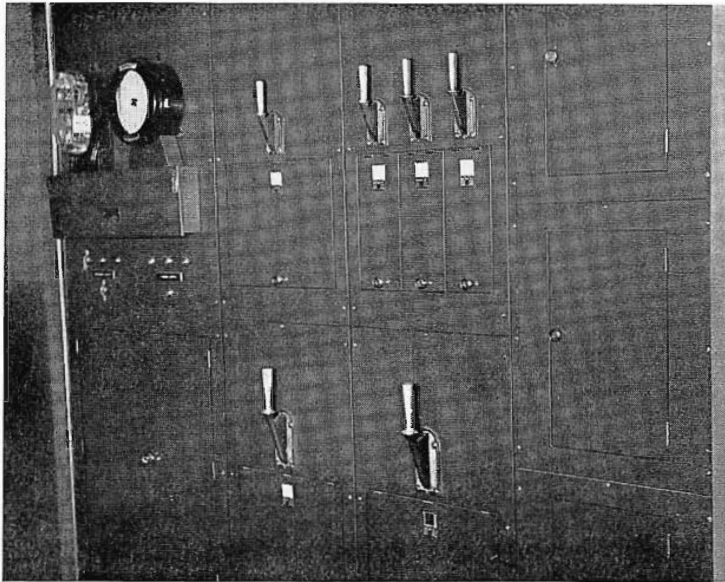

FIG. 4. All commercial power lines terminate in this switch panel located in the basement. If power is lost on the main line or on the spare line, an emergency generator is switched in automatically. The emergency generator is shown in Fig. 7.

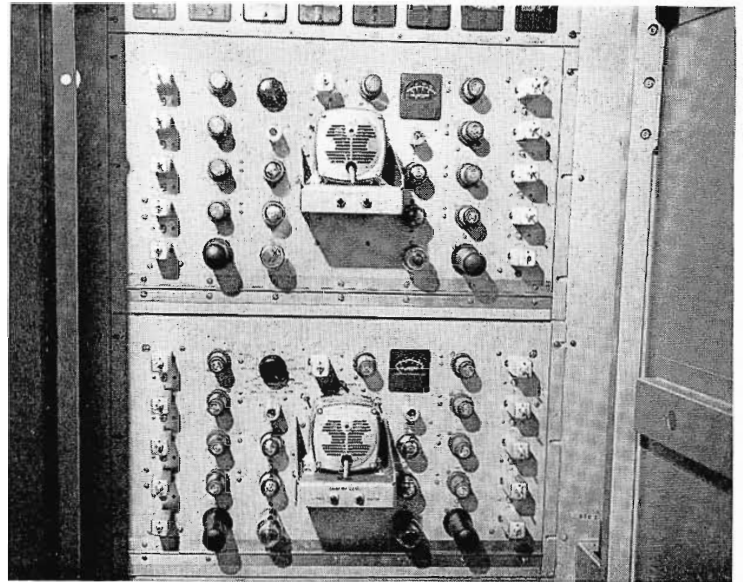

FIG. 5. The exciter-modulator chassis of the Ampliphase Transmitter have been modified for remote control operation by installing motors to raise and lower the power output control. This control, incidently, is the only normal daily adjustment required on the BTA-50G.

power, coaxial transmission line and an audio feed were run to the temporary operating position in front of the old transmitter. The four cabinets of the BTA-10H were moved in through the front entrance of the building and were raised up the

stairwell with a block and tackle. They were set up in the transmitter area on  $\frac{3}{4}$ -inch steel rods. This permitted rolling them as a unit without having to disconnect the inter-cabinet wiring harness. After the Ampliphase took over the air schedule, it was a

matter of a few hours work to roll the entire 10 kw unit to its final operating position.

#### Provisions for Remote Control

Both transmitters are equipped with the necessary remote control units. Figure 4 shows the tuning motors mounted on the front of the BTA-10H. The motor on the front control panel raises and lowers the output while the motor in the end, rectifier, cubicle controls line voltage. The two exciters on the Ampliphase Transmitter are also equipped with motors to raise or lower the transmitter output level control (see Fig. 5). Resistors for sampling dc currents and voltages as well as rectifiers for ac sampling are installed.

Switching between transmitters can be accomplished easily by remote control operation from Broadcast House. With the BTA-50G operating on the antenna and the BTA-10H filaments "hot", the transfer takes about two seconds. When the BTA-50G is not operating on remote control, a local-remote switch locks out the remote control system. Control functions are wired to terminal strips at the top rear of the 50 kw cubicles, thus only external remote control equipment need be added to complete the remote control system.

#### Conelrad Operation of BTA-10H

A Conelrad kit is installed in the BTA-10H transmitter, including a separate crystal oscillator for the Conelrad frequency, plus additional relays which switch the necessary circuits to obtain maximum output on the Conelrad frequency. These relays are operated by the remote control system, as well as manually from the front panel of the transmitter.

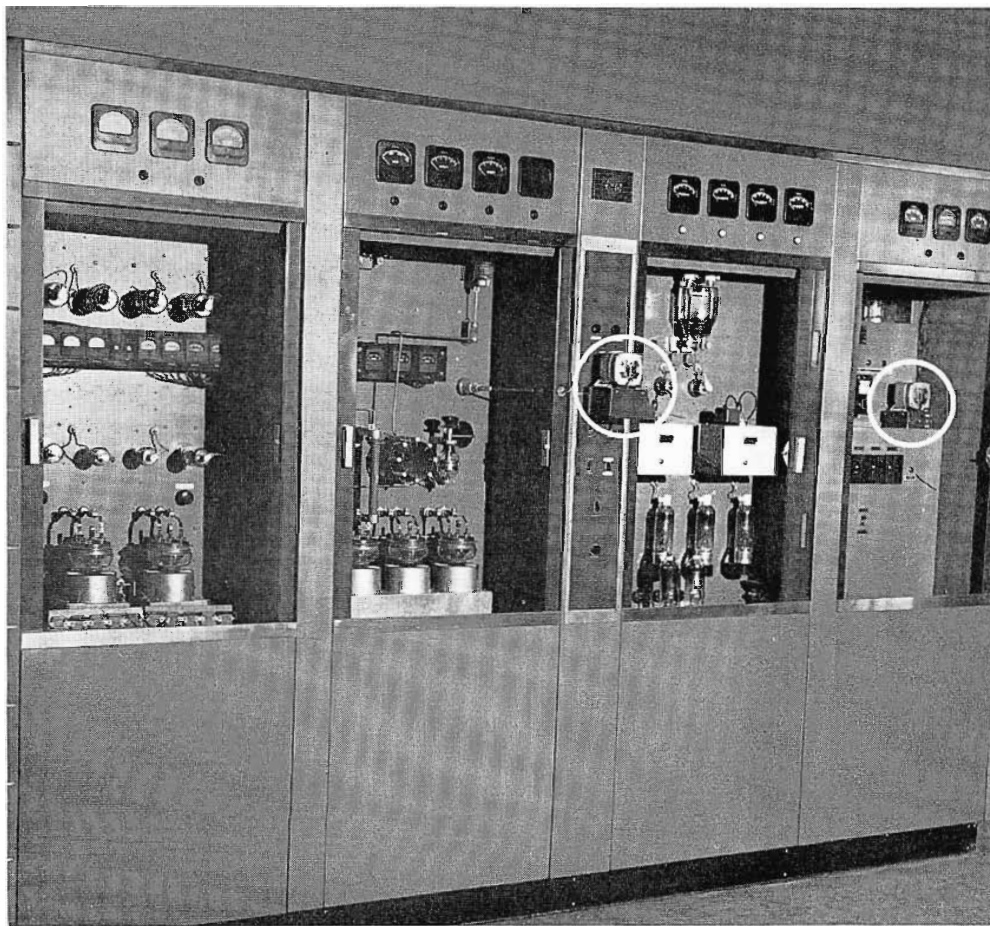

Fig. 6. A close up view of the 10-KW Transmitter shows some of the remote control provisions. Tuning motors are mounted as shown on the center panel and inside the rectifier cubicle (extreme right).



### Power Distribution and Emergency Generator

Commercial power lines enter the rear of the building and terminate in the local power company transformer vault. The power is then brought into the large switch panel located in the basement of the building for distribution (see Fig. 4).

In the case of a commercial power failure, a system of control relays automatically switches the load to the spare incoming power line. With the loss of power on the spare, the system will switch to the 95 kw emergency generator (see Fig. 7). The current capacity of the generator is sufficient to carry the load of the entire plant with the exception of the 50 kw transmitter. A lock out device on the system will not permit the 50 kw transmitter to return to the air when the generator is supplying the emergency load. The emergency power supply is adequate for operation of the BTA-10H. The 500-gallon gasoline storage tank for the generator is located underground at the front of the building.

### Unique Installation of Switch Gear

A vertical panel of  $\frac{3}{4}$ -inch fire-resistant plywood mounted on an angle iron framework behind the phasing cubicle supports the distribution transformers and switch gear for the entire 50 kw transmitter (see Fig. 8). This arrangement of switch gear

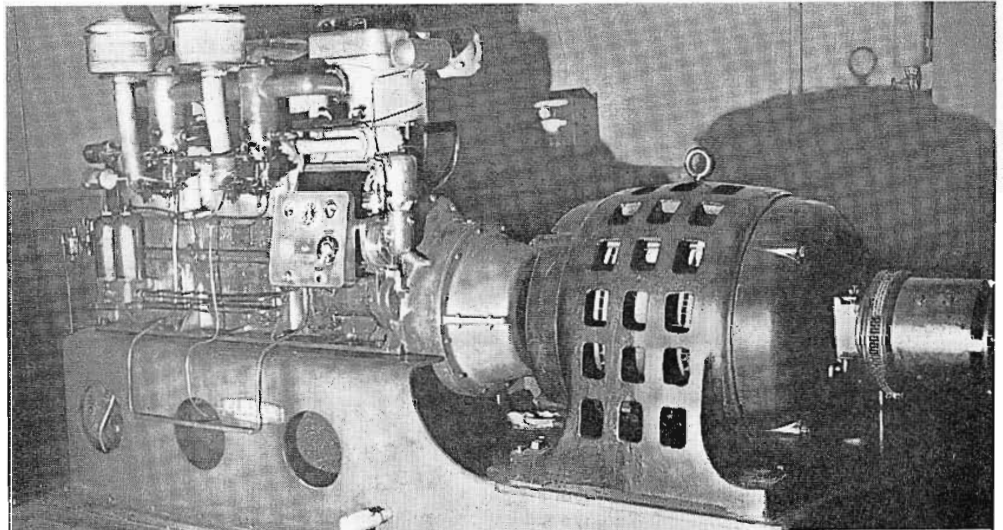

FIG. 7. This is the 95-KW Emergency Generator capable of operating the transmitter plant at a 10-kw output and its operation is automatic in the event of power line failure.

is a departure from the customary wall mounting. Both sides of the panel are used for mounting the equipment with the heavier components at the bottom. With this arrangement there is better ventilation and easier access to all components. As compared to wall mounting, this method also required less space.

The transformer vault is located in the basement directly under the switch gear panel which makes for short runs of heavy cable from the high voltage transformers

440 volt primaries. The wire duct normally furnished from the BTA-50G is modified with extra spacers and two 90 degree elbows in order to reach the switch gear panel.

### Antenna System

A three-tower directional array radiates WTOP's 50 kw signal. Each tower, 350 feet high is mounted on a concrete base (see Fig. 9). The series excited towers are fed by coaxial transmission lines from the branching network in the phasing cubicle. The large area around the three towers and

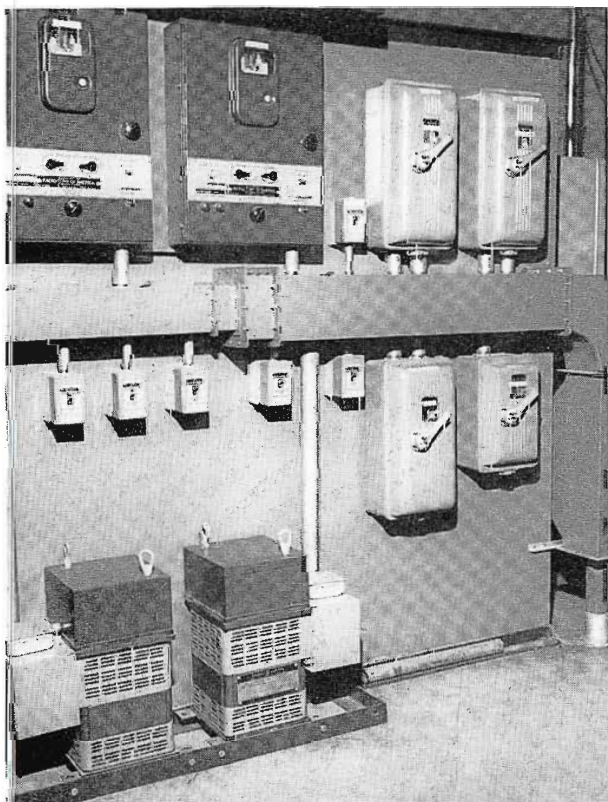

FIG. 8. Switchgear for the Ampliphase Transmitter has been mounted on this  $\frac{3}{4}$ -inch plywood panel with angle iron frame. This arrangement provides easy access to all components. Voltage regulator and distribution transformers are mounted on or near the floor for weight balance.

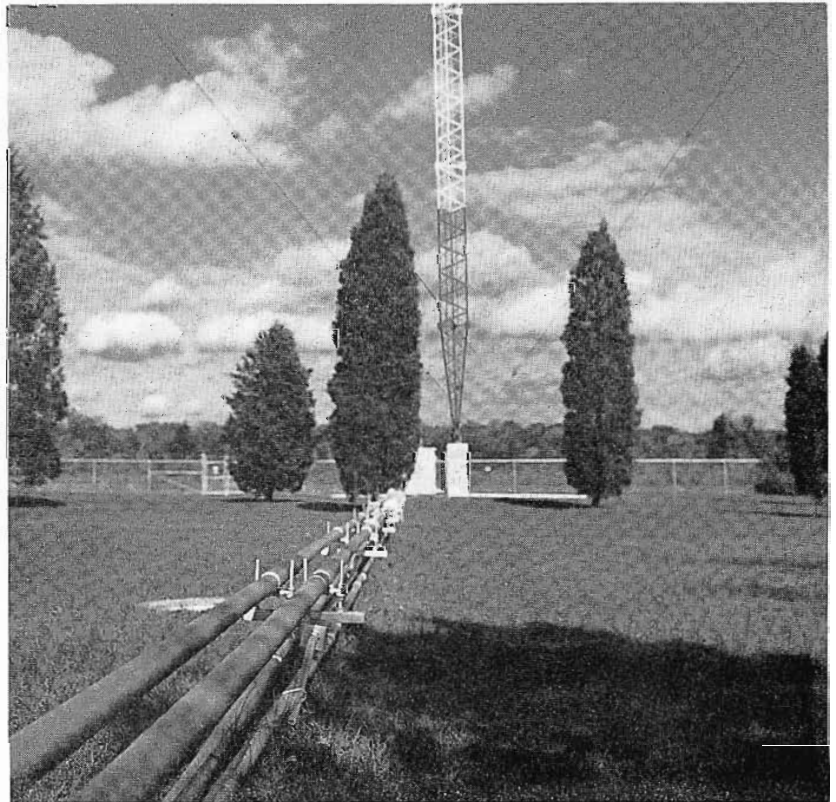

FIG. 9. Here the transmission lines are shown running to the center tower of the three-tower array. The ground system for each tower is composed of a 40-foot ground screen and 186 radials each 360 feet long.



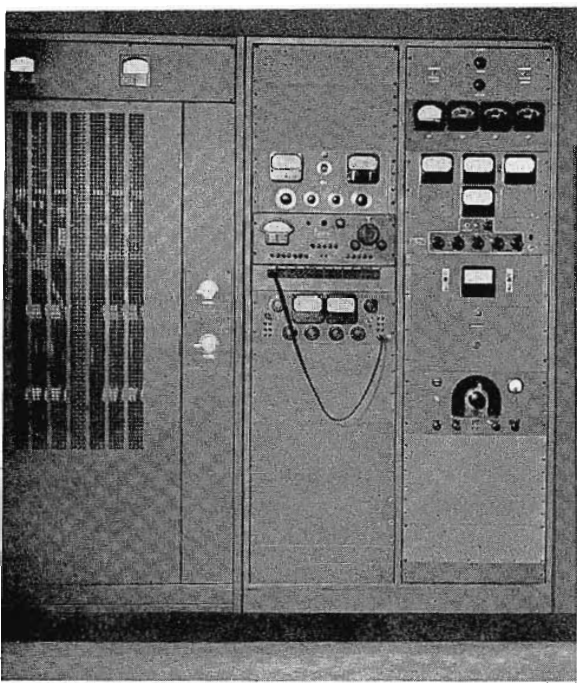

FIG. 10. This shows a portion of the phasing equipment (left) and the monitoring equipment located in the two standard size racks.

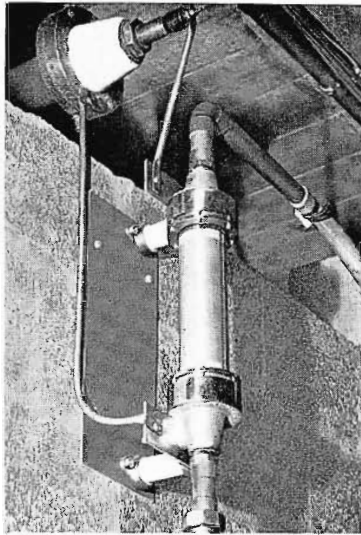

FIG. 11. The wire wound 50-kw dummy load is mounted in the basement just below the transmitters. This unit is capable of dissipating full power generated by the 50-KW Ampliphase Transmitter at 100 percent modulation. A flow of only 15 gallons per minute of ordinary tap water are required for complete cooling of the load.

copper pipe through a flowmeter and a solenoid valve. The flowmeter is interlocked with the transmitter being tested on the dummy load. Figure 11 shows the load mounted near the ceiling of the basement. Note the six-foot section of plastic hose used to isolate the high rf potential from ground.

#### Remote Control Racks

There are three equipment racks located between the phasing cubicle and the right hand end of the BTA-50G. These racks hold the remote control units and relays which operate the various transmitter remote control functions. With the completion of the racks, the manual controls for the 95 kw emergency generator and tally lights to indicate the power line in use and interlock circuits will also be included.

#### Transmitter Studio

WTOP's all night radio program originates from an air conditioned booth in the transmitter building. Figure 12 shows the RCA Type 76 Audio consolette and two turntables below the announce booth window. Ambient room noise from either transmitter is low enough that no special precautions had to be taken for sound isolation in the booth. To keep technical personnel cool during the hot summers in Washington, an air conditioning system blows cool air from louvres located over the audio racks and test gear racks.

The main studios for WTOP Radio are at Broadcast House in uptown Washington. Here WTOP has extensive studio facilities for both radio and television.\* Five radio studios, master control and tape facilities occupy the third floor of this very elaborate operation.

#### Modernization Continues

WTOP plans call for complete refinishing of the transmitter building. The flush panels above the equipment and the inside walls of the building are to be refinished. Constant improvement and modernization of its AM transmitter plant pays off at WTOP. Reliability of all equipment is emphasized because of WTOP's 24-hour a day schedule which demands the utmost in continuity of operation.

\* "WTOP Facilities", *Broadcast News*, Vol. 83, May, 1955 (This was a Four Part Article).

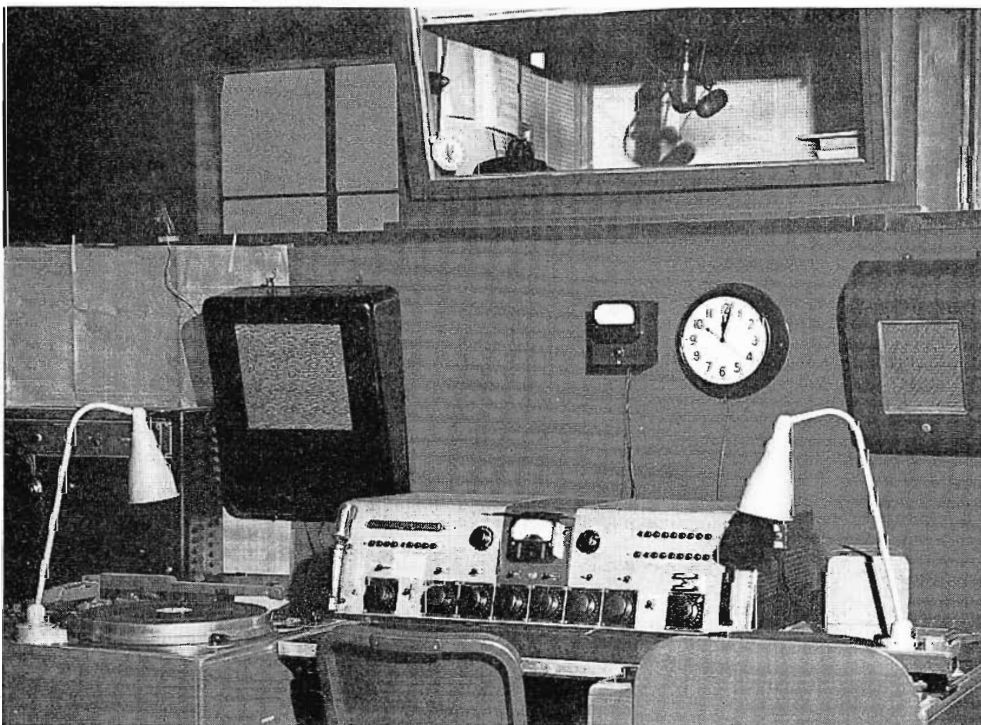

FIG. 12. WTOP originates its all-night show from this small announce booth at the transmitter site. The series 76 consolette and two turntables are all the studio equipment needed. Normal sound isolation, used in the booth, is sufficient to make room noise from the transmitters inaudible.

transmission lines is enclosed by a six-foot fence, and is landscaped to enhance the appearance of the property. The ground system consists of 186 radials each 360 feet long around each tower, except where the property line is reached. The base of each tower is in the center of a 40-foot ground screen.

#### Emergency Flat Top

During the new transmitter installation, equipment was added to the existing phasing cubicle. It was necessary to install an impedance matching network to convert the 80-ohm common point to 50-ohms for the ampliphase. The Conelrad matching network and rf ammeters for the BTA-10H

and BTA-50G were also mounted in the cubicle. The FCC granted WTOP authority to operate on an emergency flat top antenna to permit the phasing equipment to be taken out of service for the short time needed to make necessary changes.

#### Dummy Load

In the basement directly below the transmitters, WTOP has installed the RCA water-cooled dummy load. A coaxial transmission line feeds the dummy load which is mounted on stand-off insulators. The wire wound load is capable of dissipating 50 kw of rf power, cooled by ordinary tap water. The circulating water, approximately 15 gallons per minute, is supplied by one-inch

# NEW COMPACT MASTER MONITOR Type TM-35

by ALBERT REISZ  
*Broadcast and Television Engineering*

FIG. 1. This compact, lightweight Master Monitor, TM-35, features an 8-inch picture tube and calibrated 3-inch CRO. Including a completely self-contained power supply, the monitor combines excellent performance with low cost. It is designed for both studio and portable use.

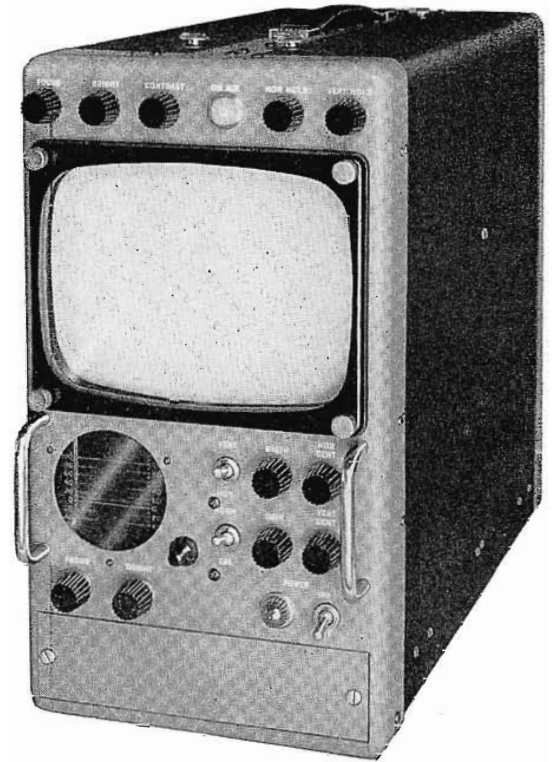

There has been a long-standing need for a portable, versatile, and highly reliable master monitor, having among other features a self-contained power supply. The new TM-35 Master Monitor, described in this article, not only fulfills this need, but also combines good performance with low cost. Its small size makes it ideal for rack or console mounting; two units fit side-by-side in a 19-inch rack or 22-inch console.

Since closed-circuit television applications are usually no less demanding in these respects, the unit is expected to find wide use there as a camera control monitor, preview monitor or an outgoing line monitor. It also provides an excellent testing unit for a multihop television microwave system or a multicamera surveillance system.

## Description

The new monitor is compact and functional; all operating controls are on the front—those for the kinescope are in line above the tube along with the “on-air” tally, while the ones for the CRO are grouped conveniently on the lower part of the panel. The power switch and indicator are in the lower right corner.

The kinescope and associated safety glass are mounted in rubber to resist collection of dust, but the glass can be readily removed for cleaning. The CRO and its related graticule and green filter are accessible from the left side. Front handles act as “knock protectors” as well as extraction devices for withdrawing the monitor from a console or rack. Beneath the

front panel of the TM-35 is a small panel which is removable to accept, depending on the application, a TS-4A switcher (MI-26162) or control panels for TK-15, TK-205 and ITV-201A Cameras (MI-26161 and MI-36202) which are available in completely fabricated kit form.

The covers are readily removable to permit setup, servicing, and maintenance. Power interlocks are provided on each cover. With covers off and interlock cheated, all power can be removed with the power switch and there are no exposed power line terminals in the unit ahead of the switch. Extra care has been taken with layout and insulation so that dangerous voltages are not easily touched accidentally with covers off and power on.

Holes in the base and along the bottoms of the covers allow air intake to the case which is exhausted through the rear by a fan. Cooling air distribution is remarkably uniform. As a result, under ambient temperatures as high as 120F, no component-damaging “hot spot” develops in the unit. The flush-type handle positioned above the center of gravity, the small suitcase form, (8½ by 15⅞ by 20¾ inches) and a total weight of only 49 pounds allow ready portability.

All external connections are made at the rear of the monitor. A permanently-attached line cord carries all of the power for the unit. Two connectors provide “loop-through” or “terminating” facility for the input video line. The seventy-five-ohm line input loops back from the input terminal

to the output terminal to minimize the line loading effect of the monitor. The synchronizing signal, if desired, is either looped through or terminated at a T-connector provided with the single sync connector. A jack is provided where tally and sync interlock voltages can be applied as required by usage. A blank panel covers an opening which permits mounting the coaxial fittings associated with items such as switchers or camera controls.

## New Features

1. *Eight-inch Kinescope* — The RCA 8HP4 rectangular kinescope allows a large picture (6¼ by 4⅝ inches with corners just touching edges) in a small space. Low-voltage electrostatic focus simplifies the equipment, 90-degree deflection shortens the whole package, and a 27-inch faceplate radius produces a very nearly flat picture surface. The kinescope is operated at 11 kv with regulation for average beam currents of 0-300  $\mu$ a. A filter glass faceplate and aluminum backing together with this regulation permit very bright pictures with high contrast even under extremely high ambient lighting.
2. *Three-inch Calibrated CRO* — The RCA 3WP1 has a flat faceplate which minimizes parallax between scale lines and phosphor for accurate level measurement. The green filter allows excellent contrast and brightness under the same high ambient lighting allowed on the kinescope.



3. *Self-Contained Power Supply* — A specially designed regulating transformer acts to supply remarkable stability and component protection over line voltage variations of 100-130 volts, or, by series connection of the split primary winding, over 200-260 volts. Tube heater voltages are held within  $\pm 3\%$  of nominal while the transformer's load-limiting feature restricts sharply the cold switching surges. Long and consistent tube performance is assured.

Another winding supplies regulated voltage to a simple silicon-rectifier full-wave doubler for the +280v, 250 ma plate supply. Line regulation holds peak-inverse voltage on the rectifier to a constant, safe value, and the filtered plate supply of 280v  $\pm 3\%$  to a constant value under its nearly constant load. The form factor of the applied wave provides almost ideal rectification with a wide conduction angle and very low peak/average current ratio in the rectifiers. Load limitation provided by the transformer permits large input capacitance without damaging surge currents. The large filter yields low ripple and eases further filtering requirements.

A neon pilot light indicates when primary power is applied under both normal and short-circuit conditions on the secondary.

4. *Centralized Control* — All operating controls are conveniently provided on the front. A minimum of setup controls are under the side covers for use during servicing or, in the case of the "Int.-Ext." sync switch, for a change in the mode of operation.

5. *Versatile Synchronization* — The scanning may be synchronized by sync stripped from a composite signal or obtained from a separate source. The "synchroguide" horizontal deflection provides excellent monitoring of signal deficiencies of importance to typical home receiver deflection performance which could go unnoticed with "driven" operation. Vertical deflection is designed to feature good performance with respect to reliable interlace.

A sync interlock relay can be plugged in for applications where non-composite local and composite remote signals are alternatively switched to the unit.

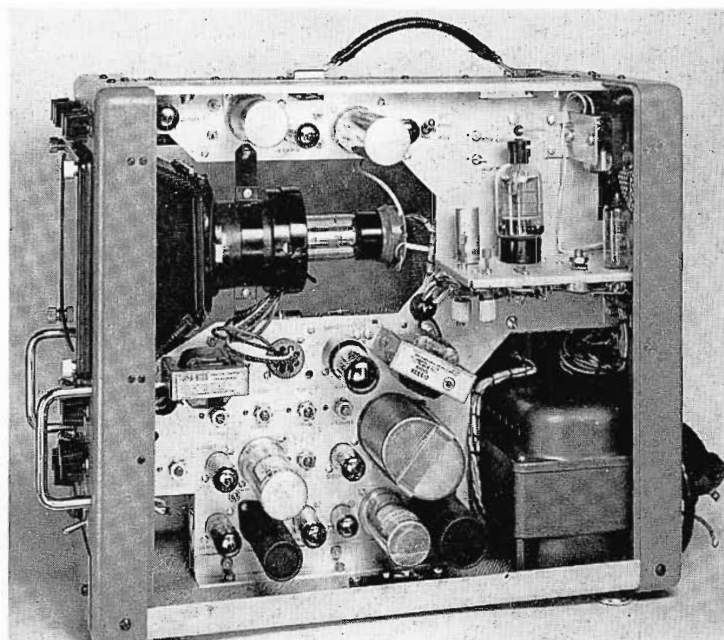

FIG. 2. View of monitor with right side cover removed. Tubes, set-up controls, self regulating power transformer and rear exhaust fan are visible.

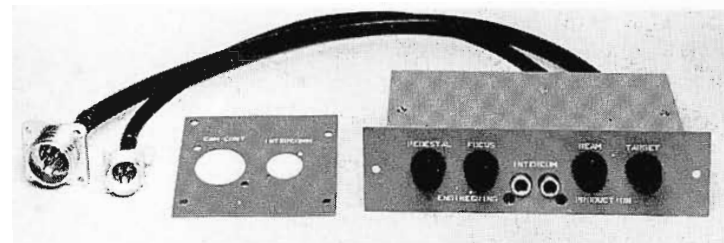

FIG. 3. Remote Camera Control Panel for use with the TK-15 Vidicon Camera. This replaces blank panel shown in Fig. 1.

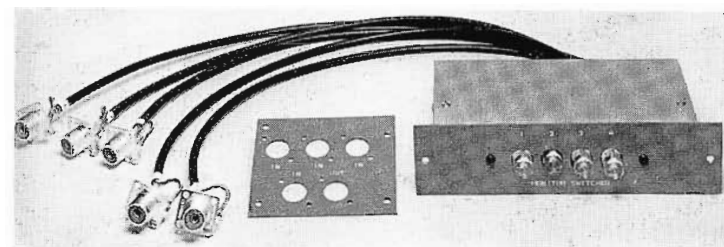

FIG. 4. TS-4A Switcher Assembly can be used as direct video line switcher or a monitor selector for the TM-35.

#### 6. *Wide choice of Accessories*

- a. Sync interlock relay.
- b. Switcher panel. This kit includes a four-pushbutton switch with integral coaxial cables and connectors for mounting at the rear of the case. Four inputs are thereby terminated or fed to the monitor for a preview monitor-type function or looped through the monitor and fed on for a very simple line monitor-switcher configuration.
- c. Camera control panels. This kit includes a camera control panel for the TK-15 vidicon camera with the usual controls plus an intercommunication jack and cabling and rear cable connections. A simi-

lar kit provides for the TK-201 and TK-205 vidicon cameras offering a compact camera control position facility.

- d. Rack and console adaptors—trim strip and perforated shelf as needed for studio installations.

#### Many Broadcast Applications

The TM-35 master monitor can serve the industry in many ways. Convenient portability has been achieved. High quality, high brightness picture and waveform displays have been provided for the many cases where high ambient light at the operating or monitoring position cannot be avoided readily. Stability and reliability are outstanding. All essentials of a master monitor function have been retained.

# new RCA automatic turntable BQ-103

*Assures Efficient, Simplified  
Handling of Recorded  
Program Material*

This new automatic turntable offers easy-to-operate semi-automated programming for 45 RPM records. Record selection, cue, and playback have been automated. "Fluffs" are minimized and program flow is smoother for the listening audience.

Records may be played in either random or sequential order. Sequential play can be fully automatic. For random play, a manual control unit permits programming of any of 200 selections.

When used in combination with a Transistorized Turntable Preamplifier (Type BA-26A), the Type BQ-103 Turntable produces an output signal capable of being fed into a console at mixer level. The preamplifier easily mounts in the BQ-103 cabinet.

*The BQ-103 Turntable offers semi-automated operation now, and becomes an integral part of the automation system later. The BQ-103 is a basic building block in preparing for automation. For complete information, call your RCA Broadcast Representative or write to RCA, Dept. B-22, Building 15-1, Camden, N.J. In Canada: RCA VICTOR Company Limited, Montreal.*

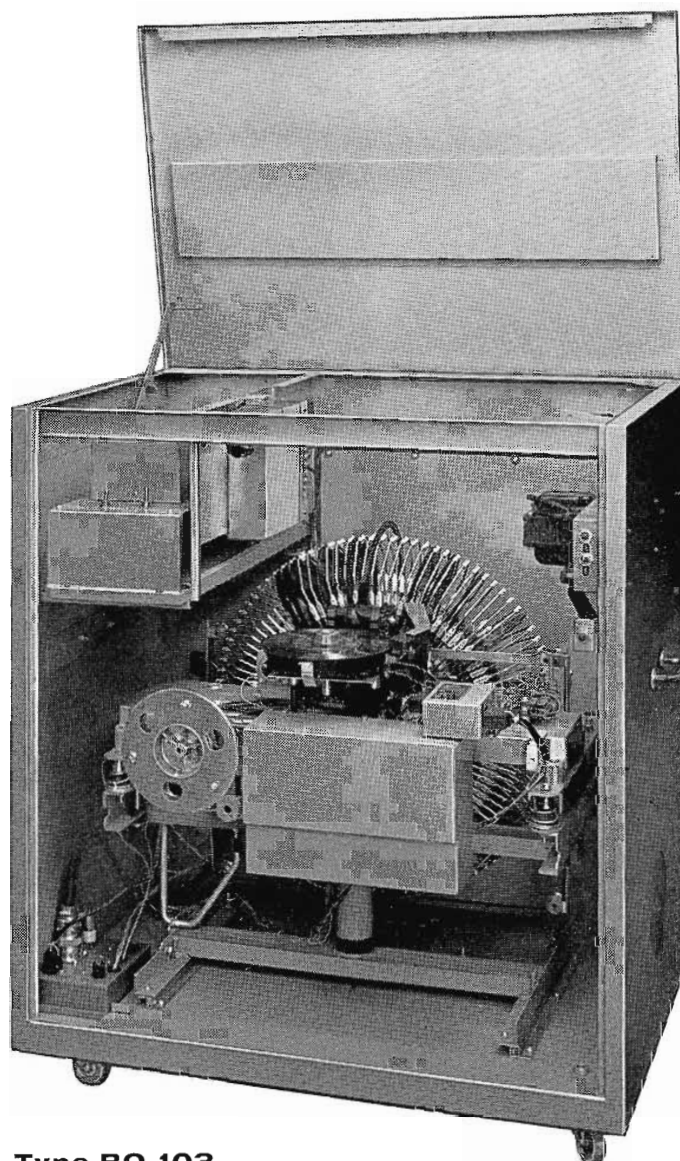

**Type BQ-103  
Automatic Turntable**

### **Manual Control Unit**

Full automatic or manual operation is possible with this single control unit, which provides push-button control of every turntable operation.

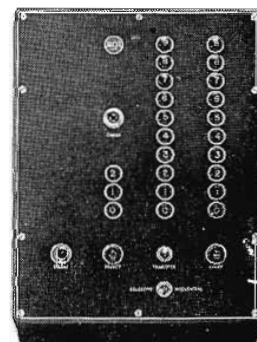

## **RADIO CORPORATION of AMERICA**

BROADCAST AND TELEVISION EQUIPMENT

CAMDEN, N. J.



for peak broadcasting performance . . .

# USE RCA'S QUARTER-CENTURY OF BROADCAST SERVICE EXPERIENCE

With RCA Broadcast Service you'll control your maintenance costs and be assured of . . .

## COMPLETE MAINTENANCE SERVICE

*from microphone to antenna!*

### HERE'S A PARTIAL LIST OF RCA SERVICES:

- **TRANSMITTER PERFORMANCE MEASUREMENTS**  
Test and tabulation of performance data for monochrome or color, visual and aural transmitters.
- **ANTENNA SYSTEM MEASUREMENTS**  
Impedance or VSWR and resistance measurements for evaluating performance.
- **COMPLETE ANTENNA INSPECTION**  
Mechanical inspection plus impedance, resistance and high voltage measurements.
- **MICROWAVE SERVICE**  
Signal to noise, frequency response, phase shift measurements and path alignment.
- **INSTALLATION SUPERVISION**  
Transmitters, studio equipment and antennas.
- **EQUIPMENT REPAIR SERVICE**  
TV cameras, microphones, pick-ups, consoles and related broadcast equipment.
- **TV PROJECTOR SERVICE**  
Scheduled preventive maintenance contract service.
- **GENERAL SERVICE**  
Adjustment and repair of studio and transmitting equipment.



FOR THIS COMPLETE BROADCAST SERVICE, CONTACT ANY OF THE RCA SERVICE COMPANY OFFICES:

Pennsauken, New Jersey  
6710 Westfield Avenue  
Telephone: NORmandy 3-8101

Hollywood, California  
909 N. Orange Drive  
Telephone: OLDfield 4-0880

Atlanta, Georgia  
160 14th Street, N.W.  
Telephone: TRinity 4-4543

Cherry Hill, Camden 8, New Jersey  
Telephone: WOODlawn 3-8000  
Extension PY-5101

Chicago, Illinois  
1322 S. Wabash Avenue  
Telephone: WEBster 9-6117



BROADCAST SERVICE  
**RCA SERVICE COMPANY**

A Division of Radio Corporation of America  
Camden 8, New Jersey

Tmk(s)®

How to end miscues and  
other costly errors

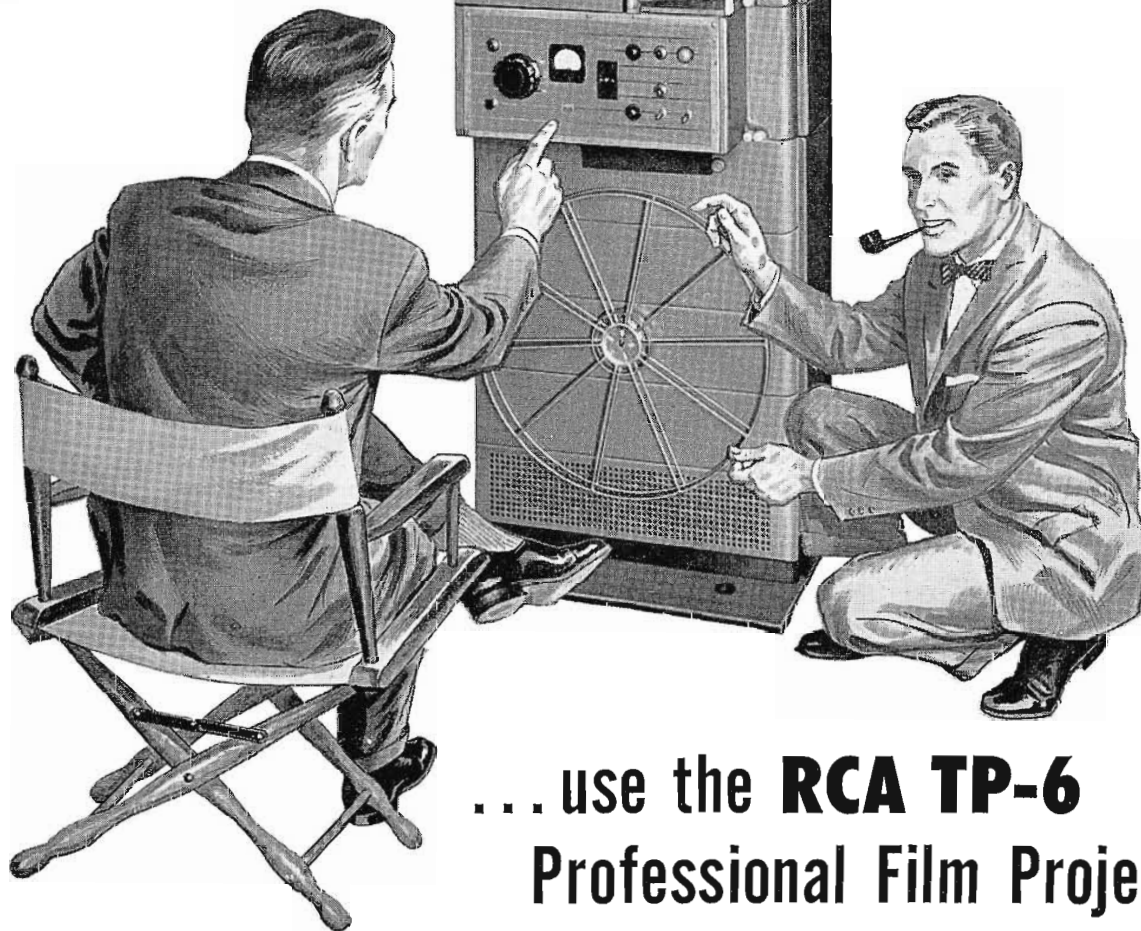

## ... use the **RCA TP-6** Professional Film Projector!

Now, in addition to the regular quality points that have made the TP-6 famous, *three new features* are offered. They include Automatic Cue, Rapid Start, Magnetic Stripe Playback!

### **AUTOMATIC CUE**

Now you can stop projectors at any predetermined film frame so that your next film sequence is cued and ready for show immediately.

### **RAPID START**

Rapid start feature provides sound stabilization in less than one second. You can activate projector start and video switch buttons almost simultaneously, thus eliminating roll cues and reducing the chance for errors.

### **MAGNETIC STRIPE PLAYBACK**

Superior reproduction of sound from 16mm. films is made possible by adding a magnetic sound system. Speed preparation of *news films* by reducing process time required between coverage and actual airing. Make your own film *programs* and *commercials*, and apply commentary, music and sound effects this easy way!

You can do all this and gain the business protection and efficient operation that comes from the TP-6's well-known built-in features... including automatic projector lamp change, gentle film handling, quick-change exciter lamp, superior picture and sound quality.

**SPECIAL**  
for TP-6 owners

Accessory attachments to provide  
new features are now available.

*Your RCA Broadcast  
Representative has the  
whole story. Or write  
for literature.*



Tmk(s) ®

**RADIO CORPORATION of AMERICA**

BROADCAST AND TELEVISION EQUIPMENT  
CAMDEN, NEW JERSEY



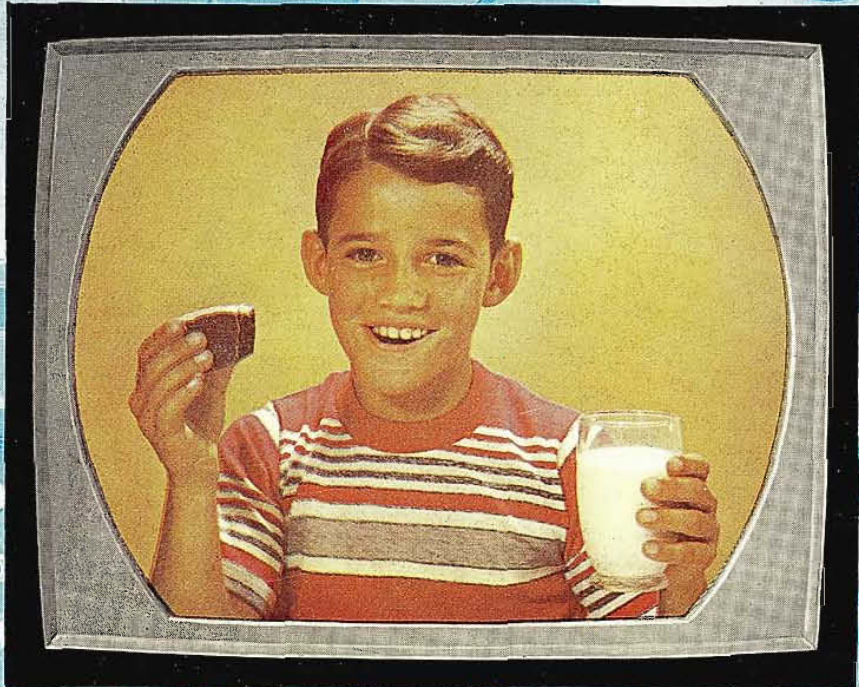

Tape Footage Indicator

Electronic Quadrature Control

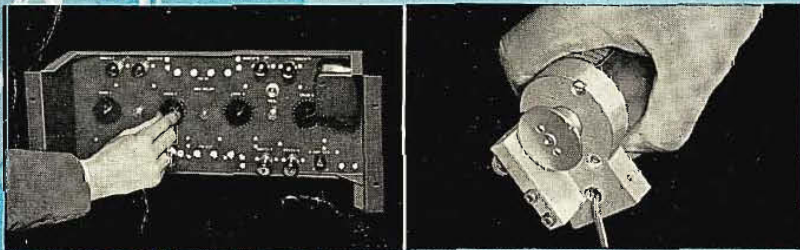

Magnetic Tone Wheel



Variable Speed Cuing Control

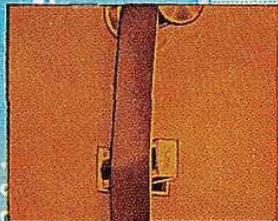

Master Erase Head

Built-in Picture Monitor

## FOR LIFELIKE COLOR ...TAPE IT RCA!

Color makes the picture real! You can shoot your programs and commercials in RCA living color and record them on lifelike RCA TV Tape! Because advanced RCA TV Tape equipment is *designed for color*, the picture as reproduced has the freshness and sparkle of the real thing . . . The RCA advanced Television Tape Recorder offers many built-in improvements for quality, such as *electronic quadrature*

*adjustment, sync regeneration, four-channel playback equalization and built-in test equipment . . .* With RCA color equipment—from precision color camera to advanced tv tape recorder to transmitter designed for color—exciting details of the original color subject come back to you—intact. *Only RCA offers this complete line of color tv equipment.* See your RCA Representative.

FOR COLOR AT ITS BEST  
MAKE IT...RCA ALL THE WAY



Tmk(s) ®

**RADIO CORPORATION of AMERICA**

BROADCAST AND TELEVISION EQUIPMENT

CAMDEN, N. J.